

Energy Futures

MIT ENERGY INITIATIVE

MIT

AUTUMN 2013

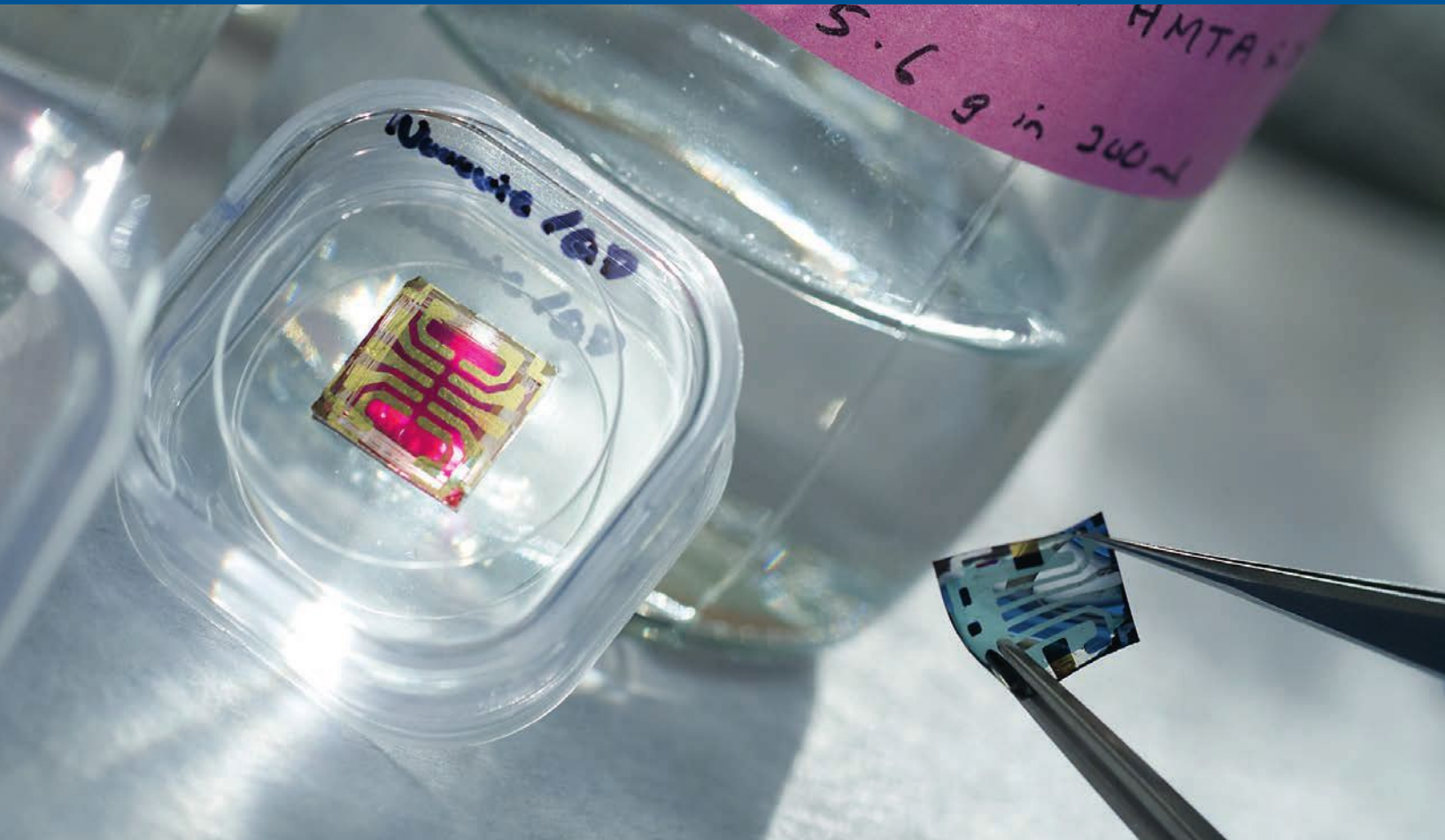

Nanowires and graphene: Keys to low-cost, flexible solar cells

IN THIS ISSUE



MIT undergraduates plunge into summer energy research

New position aims to strengthen MIT's sustainability



Event highlights need for women in clean energy

Designing high-speed motors for energy storage and more

Energy Futures

Energy Futures is published twice yearly by the MIT Energy Initiative. It reports on research results and energy-related activities across the Institute. To subscribe, send your address to stauffer@mit.edu.

Copyright © 2013
Massachusetts Institute of Technology. For permission to reproduce material in this magazine, please contact the editor.

Nancy W. Stauffer, editor
stauffer@mit.edu
617.253.3405

ISSN 1942-4671
(Online ISSN 1942-468X)



MIT Energy Initiative

The MIT Energy Initiative is designed to accelerate energy innovation by integrating the Institute's cutting-edge capabilities in science, engineering, management, planning, and policy.

MIT Energy Initiative
Massachusetts Institute of Technology
77 Massachusetts Avenue, E19-307
Cambridge, MA 02139-4307

617.258.8891
mitei.mit.edu



Main cover photo: Stuart Darsch (see page 10)
Design: Tim Blackburn
Proofreading: Kathryn M. O'Neill
Printing: Puritan Press, Inc.

Printed on paper containing 30% post-consumer recycled content, with the balance coming from responsibly managed sources.

UPDATES ON THE MIT ENERGY INITIATIVE

- 2 A letter from the director
- 3 Two MITEI Sustaining Members renew

RESEARCH REPORTS

- 4 Urban sustainability: Designing resource-efficient, appealing cities
- 10 Nanowires and graphene: Keys to low-cost, flexible solar cells
- 15 Incentives for green technology adoption: Getting government subsidies right
- 20 Fine-tuning porous materials for energy-efficient air conditioning
- 25 Designing high-speed motors for energy storage and more

RESEARCH NEWS

- 30 MIT and UC Berkeley launch energy efficiency research project
- 31 Angela Belcher wins \$500,000 Lemelson-MIT Prize

FOCUS ON FACULTY

- 32 New faculty strengthen, broaden MIT's energy expertise

EDUCATION

- 36 Energy Fellows, 2013–2014
- 37 Eni and MIT Energy Initiative announce launch of Energy Society
- 38 MIT undergraduates plunge into summer energy research
- 39 Arriving MIT undergrads immerse themselves in energy

EDUCATION AND CAMPUS ENERGY ACTIVITIES

- 40 DUSP students develop energy efficiency plan for Cambridge

CAMPUS ENERGY ACTIVITIES

- 42 New position aims to strengthen MIT's sustainability
- 43 MIT signs compact for sustainable future with City of Cambridge and Harvard

OUTREACH

- 44 Event highlights need for women in clean energy
- 48 Report maps future of alternative fuel vehicles
- 49 Students win with plan to integrate electric cars into grid
- 49 Workshop on energy-water-land nexus
- 50 New MIT student group focuses on energy and the developing world
- 51 Training and education for energy professionals

MITEI MEMBERS

- 52 MITEI Founding, Sustaining, Associate, and Affiliate Members

A letter from the director

Dear Friends,

As President Obama implements an “all of the above” energy policy agenda in Washington—with help from our friend and former colleague Ernest Moniz—we are working to implement an “all of the above” energy research agenda here in Cambridge.

In the short time since the last issue of *Energy Futures*, we have seen technology breakthroughs across the Institute. MIT researchers have designed thin, lightweight solar panels made from stacked sheets of one-molecule-thick materials. They have discovered highly active catalysts that could be key to improved energy storage in fuel cells and advanced batteries. They have devised a cheaper way to synthesize a critical biofuel component. And they have developed efficient, easy-to-retrofit methods of capturing emissions from power plants. The list goes on.

These innovations are certainly exciting. But they raise an important question: How do we bring our innovations from the lab to the marketplace? While MITEI’s members continue to help us identify critical research topics and transfer results to the energy marketplace, the Institute is taking this process one step further by placing new emphasis on the production of our innovations. This topic was addressed by the Institute-wide Production in the Innovation Economy (PIE) commission during a two-year study completed this past September. And it will be the driving force behind a new MIT initiative focusing on innovation.

Announced in October, the Innovation Initiative will encompass both innovation and production—activities that are “deeply linked and mutually reinforcing,” as the PIE commission

demonstrated. Following MITEI’s example, it will connect interdisciplinary research with development and deployment by directly engaging stakeholders—from innovators and entrepreneurs to large corporations and policy makers.

MITEI is an appropriate model for the Innovation Initiative in many ways, but we can also act as its partner going forward. As we look to contribute to this Institute-wide endeavor, we will focus new attention on ways to improve advanced manufacturing and industrial processes. In particular, we will aim to increase energy efficiency to reduce costs and cut harmful emissions. We will also explore ways to scale the manufacture of energy systems and components to match the large-scale demand for energy.

We will work to make emerging energy technologies such as solar, wind, and other no- and low-carbon sources more competitive in the marketplace. As we continue to develop innovative devices and systems, we will place greater emphasis on ensuring that they can be produced using abundant, inexpensive materials and low-cost mass manufacturing processes.

Even when solar and wind technologies are economically competitive, their widespread deployment will require a means of storing the energy they produce to use when the sun is not shining and the wind is not blowing. There is already a critical mass of research across MIT addressing energy-storage systems, ranging from advanced batteries to fuel cells to flywheels. Now we will seek to leverage that work through enhanced organization and coordination that may accelerate its impact and reveal new opportunities for collaboration.

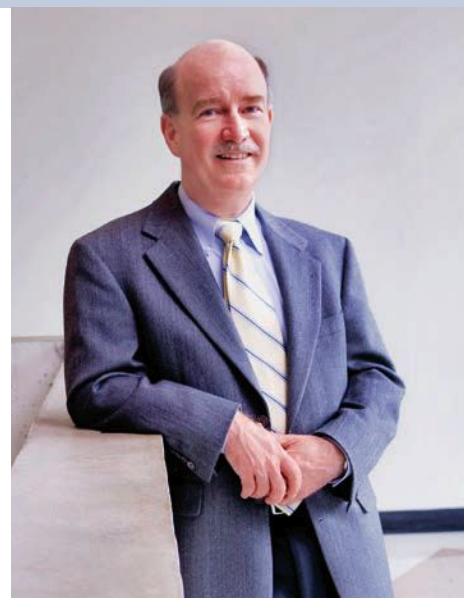

Photo: Webb Chappell

MITEI’s research, education, campus energy, and outreach programs are spearheaded by Professor Robert C. Armstrong, director.

Until we are able to store clean energy at a large scale, we will continue to rely on natural gas as a primary energy source and as a backup source for renewables. Accordingly, we are working to develop new technologies that can help energy companies unlock the potential of stranded resources and manage fugitive emissions. In addition, we are examining the evolving nature of global natural gas markets as well as the relationship between natural gas and electric power in an era of growing use of distributed and smart grid systems.

To further expand our natural gas research portfolio across the Institute, we have encouraged researchers to submit proposals on that topic to our Energy Research Seed Fund Program—a program explicitly designed to encourage innovation by supporting early-stage research on a variety of energy and related environmental topics. To date, this program has helped to fund 118 projects, led by well-established energy experts and by new faculty who need startup

Two MITEI Sustaining Members renew

support as well as by others who are applying their expertise in different fields to energy for the first time. Some seed grant recipients have gone on to attract additional public and private funding, while others have entered the marketplace aided by venture capital funding—a key step on the pathway to linking innovation to production.

Given the innovative spirit that pervades MIT, it comes as no surprise that students at the Institute also demonstrate creativity, coming up with ingenious ideas and inventions to address energy, environment, and health issues, especially in developing countries. Some of the most creative are recognized through the Making and Designing Materials Engineering Competition (MADMEC), run each year by the Department of Materials Science and Engineering. This year, first prize went to four students who designed and built “Wristify,” a thermoelectric bracelet that monitors air and skin temperature and sends tailored hot or cold pulses to the wrist, warming or cooling the body and reducing the need for energy-consuming heat and air conditioning. Other MADMEC-winning technologies include a system of inexpensive, small LED lights that run on solar-powered, rechargeable batteries and can stick to any surface, and a novel polymer that can be applied to water filters to remove heavy metal ions, such as lead and mercury. These examples typify the unique technologies being developed by MIT students—technologies that often go on to be commercialized by the students through their own startup companies.

As MITEI continues to support the many energy-related activities of MIT’s faculty, students, and staff, I am delighted to announce an expanded

leadership team to help us carry out our mission. The following individuals have taken on new or elevated roles at MITEI.

- Robert Stoner, deputy director for science and technology, previously served as MITEI associate director and continues as co-director of the Tata Center for Technology and Design.
- Martha Broad, executive director, joins us from the Massachusetts Clean Energy Center, where she oversaw programs and studies that led to the commercialization of clean energy technologies.
- Louis Carranza, associate director, was previously vice president for strategic development at IHS CERA.
- Francis O’Sullivan, director of research, has been at MITEI since its early days, most recently serving as executive director of the Energy Sustainability Challenge.

As MITEI continues to grow and strengthen, I can think of no better team to complement the Initiative’s already outstanding staff. Together, we will build on MITEI’s strong foundation and bold, interdisciplinary approach to deliver global energy solutions in an age of innovation.



Professor Robert C. Armstrong
MITEI Director

November 2013



Photos: Justin Knight

Robert Bosch

On July 29, 2013, Maria Zuber, MIT’s vice president for research (left), and Michael Mansuetti, president of Robert Bosch, LLC, renewed the collaboration between the two institutions. Bosch will continue as a Sustaining Member of MITEI with a research portfolio focusing on energy efficiency and renewable energy research projects.



Total

Shaffiq Jaffer, vice president for corporate science and technology projects at Total (far left), poses with current and former Total-MIT Energy Fellows at an event during MITEI’s 2013 Fall Research Conference. Total renewed its MITEI Sustaining membership, which includes a set of sponsored research projects focusing on subsurface oil and gas exploration and development.

MITEI’s Sustaining Members provide \$5 million over five years, supporting named Energy Fellows at MIT, MITEI’s seed fund program, and specific research programs or projects responsive to their own strategic energy objectives.



Urban sustainability

Designing resource-efficient, appealing cities

Christoph F. Reinhart of architecture has been developing tools that architects and urban planners can use to design neighborhoods—including buildings, parks, courtyards, and trees—that are energy efficient, environmentally friendly, and appealing and comfortable for residents.

This research was supported in part by a seed grant from the MIT Energy Initiative (MITEI) and by United Technologies Corporation, a Sustaining Member of MITEI. For more information about funding, see page 9.

Photo: Dominick Reuter

A modeling tool from MIT's Sustainable Design Lab is now helping to support the sustainable growth of the world's rapidly expanding urban areas. Rather than planning one green building at a time, urban designers and architects can draw a new neighborhood or city and then use the tool to calculate energy use and emissions for the entire collection of buildings in their design. They can also determine how comfortable the residents will be—both indoors and outdoors—and how likely they will be to walk rather than drive. In earlier work, the MIT researchers developed a "solar map" of Cambridge, Massachusetts, that enables residents to find out the optimal solar photovoltaic (PV) installation for a particular rooftop, how much it would cost, and how soon the investment would pay off.

One way to reduce global carbon emissions is to make urban neighborhoods more resource efficient. Buildings are responsible for high levels of energy use and carbon emissions—a fact that has inspired the development of simulation tools that can predict the future energy use of individual buildings with remarkable accuracy. But those tools can't effectively model groups of dozens or hundreds of buildings. The problem? In dense urban settings, buildings interact strongly with each other and with objects such as trees and hills. The results—shaded areas, urban heat islands, localized wind patterns, and so on—can signifi-

cantly alter the energy use and associated carbon emissions of each building.

“Modeling the sustainability of cities has been a huge challenge for researchers,” says Christoph F. Reinhart, associate professor of architecture and director of the Sustainable Design Lab in MIT’s Building Technology Program (BTP). “But with the rise of geographic information systems [GIS], we suddenly have these immense public databases that give us enormous amounts of information about buildings.” By combining such data with well-developed modeling tools for single buildings, he and a group of PhD

candidates in the BTP have been developing tools that will help ensure the growth of cities that are not only resource-efficient and environmentally friendly but also attractive to residents.

Mapping a city’s solar potential

As a first test of their modeling approach, the researchers developed a solar map that analyzes the potential for installing PV systems on rooftops in Cambridge, Massachusetts. Working with the City of Cambridge, Reinhart and graduate student J. Alstan Jakubiec first generated a detailed topographical model of Cambridge based on publicly

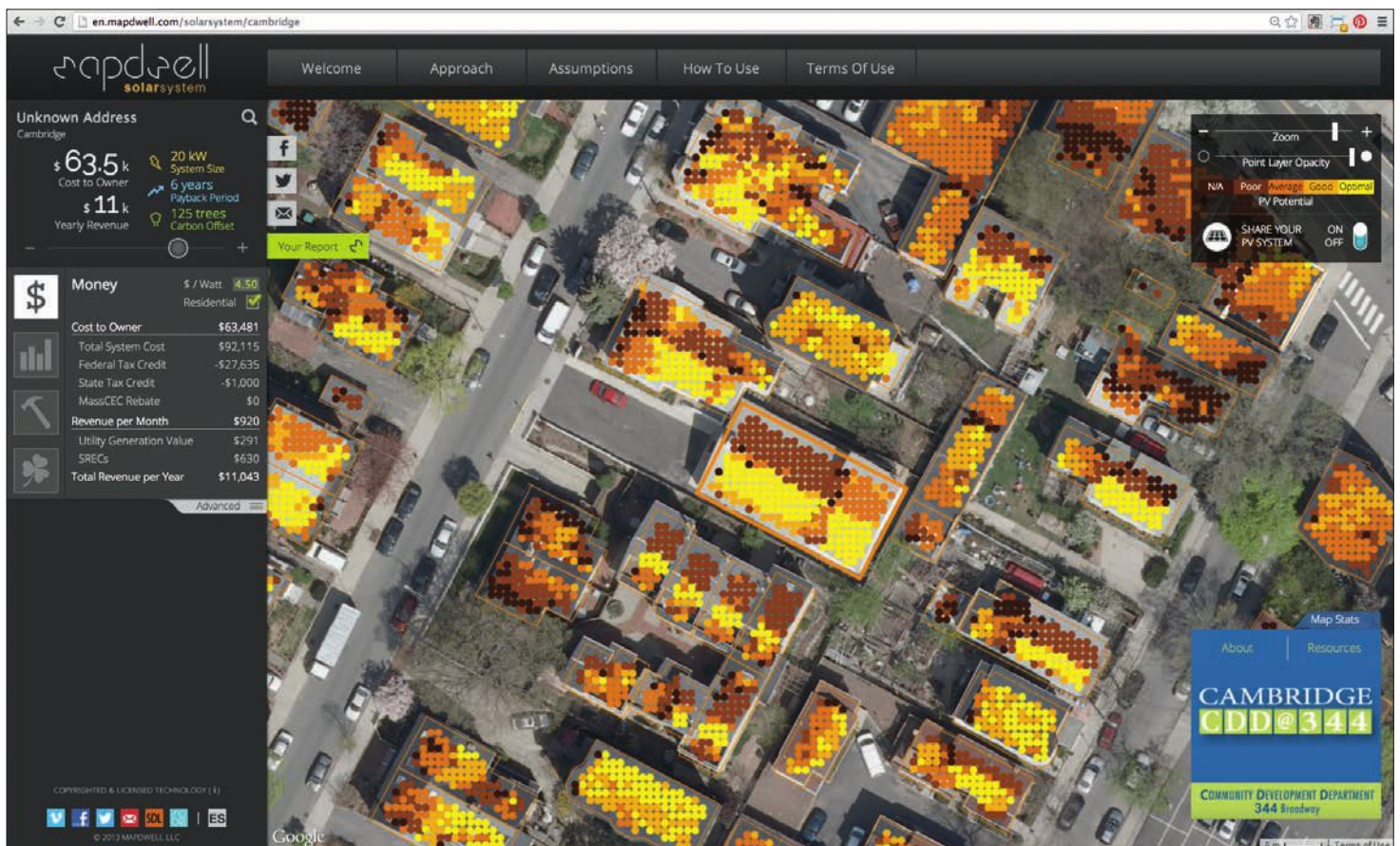

This screenshot shows sample results from an analysis using the solar map of Cambridge, Massachusetts. The colored dots indicate the solar potential of specific areas of each rooftop. The panel at the left shows the optimal size for a solar installation at a specific (unidentified) address as well as its cost, payback time, and additional financial information. Other display options provide technical and environmental details. The online system was developed by Mapdwell (www.mapdwell.com), an MIT spin-off company that has licensed the technology and is now working with other cities and regions worldwide to implement solar maps for their urban areas.

available GIS data, including each building's type, footprint, exterior materials, year of construction, and more. They also drew on data from a publicly funded LiDAR survey. (LiDAR—Light Detection And Ranging—is a remote sensing technique in which instruments on aircraft use laser beams to measure the distance to objects on the ground.) Those measurements provided critical information such as the shapes of individual roofs (angled roofs can have shady sections not suitable for PVs) and the presence of nearby buildings, trees, and hills that may block or reflect the sunlight.

Drawing on historical weather data, the researchers determined hourly temperature measurements and sky conditions (overcast or sunny) over Cambridge for a typical year. Based on the roofing materials on individual buildings, they estimated how hot the roofs would get—a key factor in getting an accurate outcome because hotter PV systems are less efficient. They then analyzed annual solar radiation on the surfaces in their 3-dimensional model of Cambridge using DAYSIM, daylighting analysis software that was developed by Reinhart and is now used worldwide. Based on those results, they generated an online map of 17,000 rooftops, each consisting of smaller sections of various colors indicating which parts have excellent, good, poor, and no solar potential. A Boston-based collaborator—Eduardo Berlin from Modern Development Studio LLC—then designed an online viewer as well as a financial analysis module for PV installations.

Using the online solar map—available at en.mapdwell.com/solarsystem/cambridge—residents and other users can type in a street address, find out how many square feet of the roof are

Model of a mixed-use development in Boston

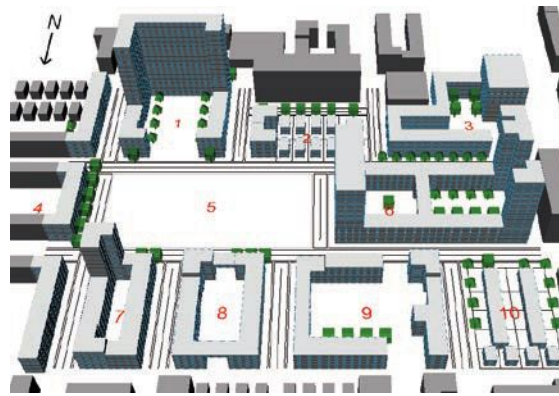

- 1 Landmark building with explicit mixed land use
- 2 Residential block and single-family housing units
- 3 Irregular courtyard composition with massive block
- 4 Row houses (in a straight line)
- 5 Park
- 6 Mixed use with courtyards
- 7 Narrow courtyard complex with a relative high-rise
- 8 Explicit mixed land use with wider courtyard
- 9 Widest courtyard with low-rise arrangement
- 10 Single-family houses in row and individual units

Using umi, the researchers performed a case study of this hypothetical neighborhood in Boston, Massachusetts. They defined the layout of buildings, parks, courtyards, trees, and other objects in their neighborhood and classified each building using templates to specify its age, style, materials, use, and so on. They then used umi's simulation tools to analyze a series of metrics indicating the sustainability of their design.

Energy analysis of the mixed-use development



This diagram shows the results of analyzing the model neighborhood with umi's energy module, which calculates the energy use of individual buildings taking into account shading and other impacts of nearby buildings, trees, and other objects. Buildings with high energy intensity are readily evident by their red coloring.

optimal for solar panels, calculate the actual cost of installation (including federal and state tax credits), determine annual savings and payback time, and find out the annual reduction in carbon emissions that would result. A screenshot from a sample analysis appears on page 5.

Urban sustainability—a broader view

But Reinhart notes that “just putting a bit of PV on some roofs” doesn't make a city sustainable. To be truly sustainable,

a city must have low energy use and low carbon emissions, and it must be a place where people want to live. Reinhart and his collaborators therefore formulated “umi,” a modeling tool that addresses multiple aspects of sustainability using simulation software that architects and urban planners will find familiar and easy to use. Using a popular computer-aided-design modeling platform called Rhinoceros, users of umi first create a basic 3-dimensional model of their existing or proposed neighborhood or city. They then use

Total energy use and carbon emissions of the development

familiar simulation programs that run on top of the Rhino software to analyze how the defined urban setting performs on four key metrics: energy consumption, transportation, indoor daylighting, and outdoor comfort.

Case study: Boston

To test umi's capabilities, Reinhart's team performed a case study of a hypothetical mixed-use development in Boston, Massachusetts. To begin, they selected Boston as their location, thereby defining hourly radiation data, temperature, relative humidity, and other key parameters. They then built a model of their neighborhood—shown on page 6 (top)—consisting of buildings, trees, and other shading objects along with parks, courtyards, and walking paths. To classify each building, they chose from a series of “templates” that specify age, style, materials, use, and so on. They then used the simulation programs to examine the sustainability of their neighborhood.

Energy. For its energy “module,” umi uses a popular simulation tool called EnergyPlus to calculate the energy use of individual buildings while taking into account the impacts of neighboring objects such as other buildings and trees. Performing that analysis for their Boston development, Reinhart and Jakubiec generated the figure shown on page 6 (bottom). Colors in the diagram show the level of energy use intensity converted to kilowatt-hours per square meter per year. Aggregating their hourly building-by-building results, they generated the curves on this page, which show total use of electricity (blue) and natural gas (red) and associated carbon emissions (green) per day between January 1 and December 31.

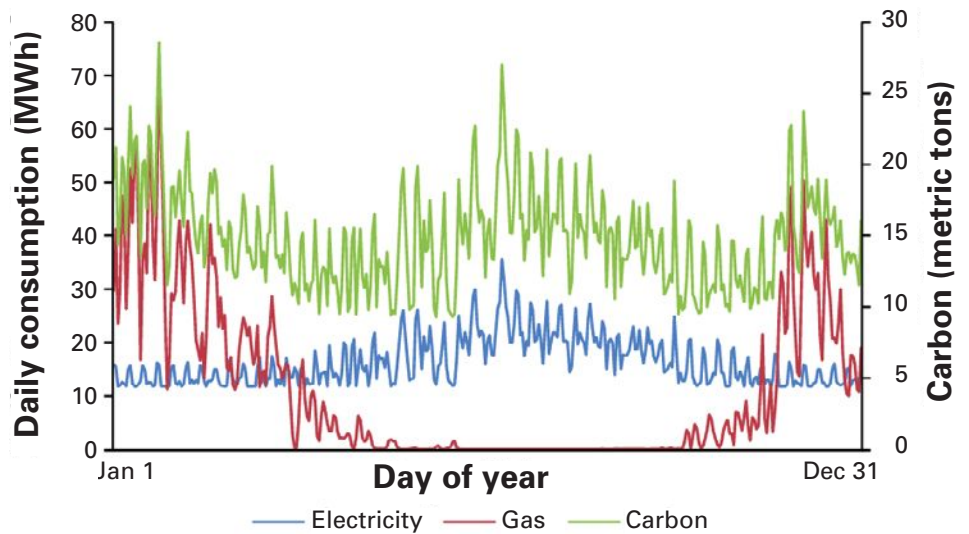

Using umi, the researchers performed a case study of the hypothetical neighborhood in Boston. These curves show total hourly use of electricity and natural gas and associated carbon emissions for the neighborhood over a full year. A notable feature is the high summertime peak in electricity consumption and carbon emissions. One approach to reducing those peaks would be to target the high-energy-intensity buildings in the figure on page 6. But in a dense urban area, planners can consider other approaches, for example, reorienting certain buildings, altering the distances between them, or changing the number of commercial versus residential buildings because they're used at different times. Using umi, planners can try out different options to find the one that's most energy efficient for the whole neighborhood.

Mobility. Since transportation also contributes to carbon emissions, another module—designed by Reinhart and graduate student Tarek Rakha—examines whether residents must drive or can walk to schools, shops, restaurants, and other amenities. The module draws on Walkscore, a popular online tool for measuring how walking-friendly an area is based on proximity to amenities as well the presence of sidewalks, the length of blocks, and other factors. In addition, umi combines the Walkscore results with its data on urban terrain and outdoor comfort to estimate the number of trips throughout a year that will actually be made on foot. In initial analyses, the Boston development proved largely “very walkable” with several sections designated as “a walker’s paradise.”

Indoor daylight. Bringing natural light indoors increases the comfort and well-being of occupants while reducing the need for energy-consuming artificial light. Drawing on the DAYSIM model,

umi calculates annual daylight availability for each story in each building. Analysis of the Boston neighborhood—led by graduate student Timur Dogan—showed that about half the floor area inside the buildings receives some daylight, with about 15% of the total area receiving enough light to require no supplementary artificial lighting.

Outdoor comfort. The daylighting model also generates insights into how people will fare outdoors by examining conditions between the buildings. To assess outdoor comfort, umi combines hourly outdoor air temperature and solar radiation and then deems an outdoor space “hot” if the ambient temperature is above 28°C and there is direct incoming solar radiation and “cold” if the temperature is below 5°C and no direct radiation is incident. The figures on page 8 show results from the Boston case study, with the left-hand diagram showing hot spots in summer and the right-hand diagram showing cold spots in winter.

Outdoor comfort in the Boston neighborhood

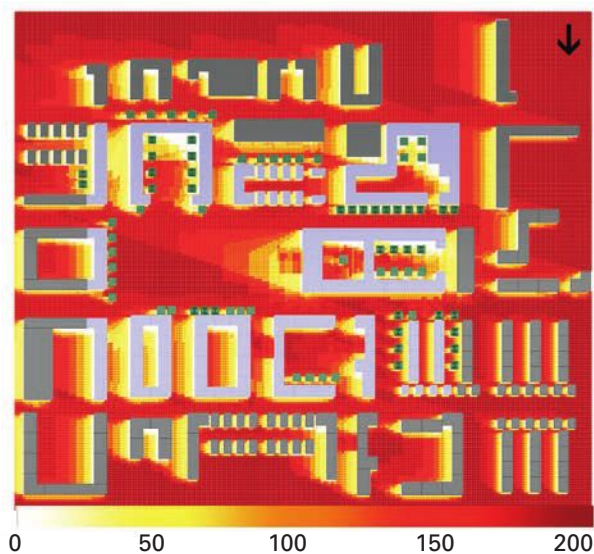

Hours per year with air temperatures above 28°C and direct solar radiation

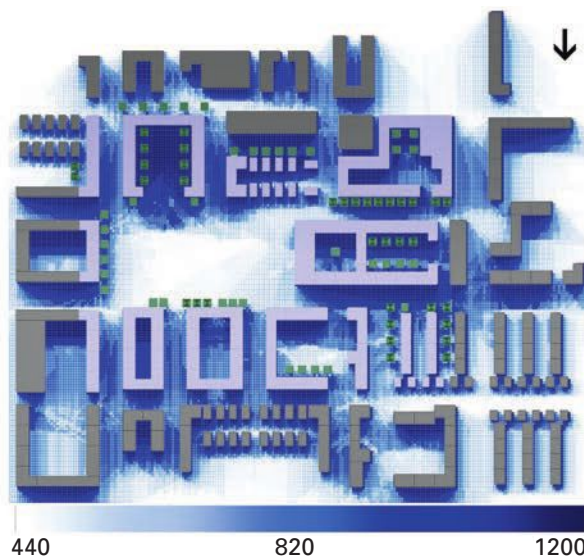

Hours per year with air temperatures below 5°C and no direct solar radiation

These diagrams show results of analyses with umi's outdoor comfort module. The left-hand diagram shows hot spots in summer, defined as areas with ambient temperatures above 28°C and exposure to direct solar radiation. The right-hand diagram shows cold spots in winter, which are regions with temperatures below 5°C and no direct radiation. While umi's comfort model is relatively crude and ignores factors such as local wind effects, it does provide guidance on where local shading or changes in building layouts might help.

Student demonstrations

For a good demonstration of umi's full capabilities, Reinhart turned to student projects from his spring 2013 MIT class, Modeling Urban Energy Flows. More than two dozen MIT and Harvard graduate students in architecture, urban planning, and building technology enrolled in Reinhart's class and simultaneously enrolled in a studio class taught by Miho Mazereeuw, assistant professor of architecture at MIT. In Mazereeuw's class, they designed a solution for a real architecture problem somewhere in the world. In Reinhart's class, they analyzed their proposed design using umi plus a small financial model that looks at cash flows.

One interesting analysis focused on Hunter's Point, San Francisco, California, a region where redevelopment is now in progress. Using umi, the students analyzed the commercial development now being implemented as well as their own design for the same project, which is shown on page 9 in a diagram prepared by graduate students

Christopher Mackey and Fei Hong of architecture. They added one factor to both analyses: resiliency to heat waves in 2080. In their design, they included outdoor spaces such as plazas, boulevards, and alleys that would reduce heat island effects, serve as "cool islands," and permit access and penetration of daytime light. In addition, they oriented parks to capture the prevailing winds; they spread out commercial amenities to make them readily accessible to more residents; they adjusted the floor heights of buildings for optimal daylight; and they added natural ventilation and night cooling to reduce energy use. They then developed a "Score Card" presenting the quantitative results for each of the factors analyzed by umi (shown at the right in the figure). Compared to the developer's proposal, their design more than doubled population density, almost halved energy use, significantly increased both daylit area and accessibility, and slightly reduced comfort—all with essentially no change in the financial burden.

To Reinhart, the student projects confirm both the accessibility and the

effectiveness of the umi platform. Their quality and findings demonstrate that the current version of umi can be learned and successfully applied by early career design professionals in a way that will lead to environmentally superior neighborhoods.

Ongoing work, continuing challenges

Reinhart and his colleagues have released the first public version of umi (available at www.urbanmodeling.net), and they are now working with the City of Vancouver, Canada, and the government of Kuwait to apply umi to selected neighborhoods. Meanwhile, they are continuing to expand and improve umi's capabilities. One goal is to incorporate "embodied" energy and emissions, that is, the energy and emissions associated with the construction process and the materials used. Graduate student Carlos Cerzo is developing a module that will account for embodied energy and emissions and will calculate any savings that will result from initial energy-efficient investments as the building operates

Designing for resilience to future heat waves

PROPOSED Heat-Resilient Hunter's Point

Balancing Sustainability, Energy Use, and Density with Heat Wave Resiliency for 2080

THREE TYPES OF OUTDOOR SPACES FOR HEAT RESILIENCY

over time. Other, more fundamental research focuses on understanding microclimates that can occur around grouped buildings—for example, due to generated exhaust heat or redirected local wind patterns—and can profoundly affect the operation of individual buildings and the well-being of people outdoors. Leslie K. Norford, professor of architecture, is now completing an “urban weather generator” that will be incorporated into umi, providing invaluable inputs into all of the simulation modules.

According to Reinhart, the biggest challenge for the group right now is getting energy consumption data from cities to use in validating umi. “In the US, you can get lots of information about the buildings in a city but not on how much energy is used in them because that’s considered personal information,” he says. They know their simulation models work for individual buildings. But the step of going from individual buildings to the urban scale requires estimating certain inputs, and that process necessarily produces errors. “We can make good educated guesses, but the real test will be when we can get into neighborhoods and compare the actual data with our calculations,” says Reinhart. “We need to get energy use data for a few hundred buildings. It’s an ongoing process. But I’m sure we’ll get there.”

Reinhart notes that urban sustainability is a “big buzzword right now,” and lots of work is going on in the area. But there tends to be a shortage of hard data. “We try to come up with the best objective measures we can,” he says. “We don’t claim that you should look only at the objective metrics because then everybody will say that the city has to be livable, desirable—and I completely agree. But I think our work

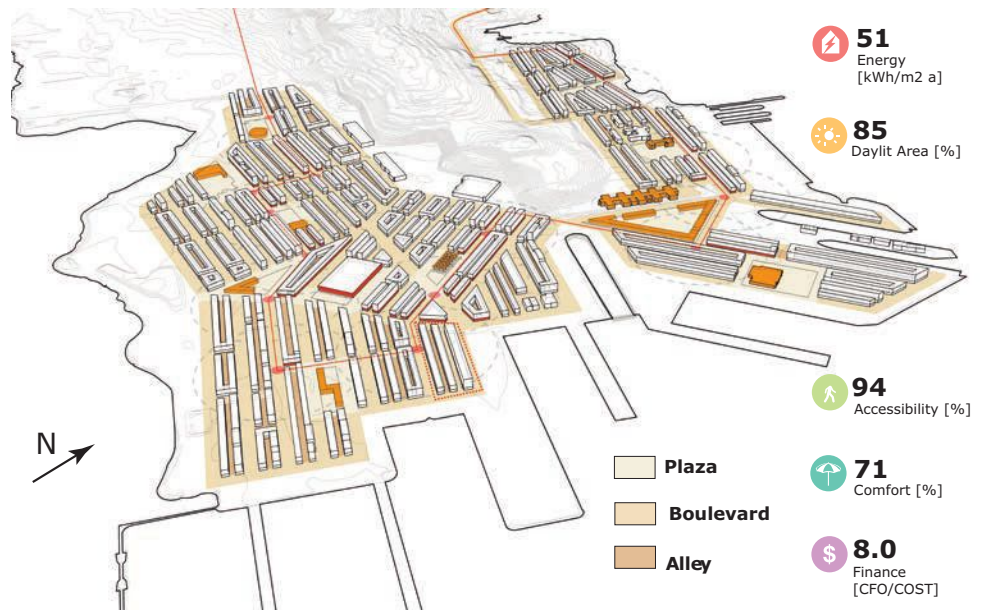

In an MIT class project, graduate students prepared this design for Hunter's Point, San Francisco, California, a region now being developed by a commercial firm. Their goal was to maximize sustainability in light of possible heat waves in 2080. Among the features in the students' sustainable design are plazas, boulevards, and alleys that will reduce the heat island effect and permit access and penetration of daylight. The orange color indicates public buildings such as libraries, museums, and schools that serve as anchor points/bus stops for the sustainable transportation network. In many cases, squares around the buildings collect runoff from surrounding neighborhoods and process it through artificial wetlands that serve as public parks. Using umi to analyze their overall design, the students generated values for the various metrics shown at the right—most of which are substantially better than those they calculated for the development now being built.

provides a meaningful way to look at how well a city does on certain levels, and that analysis should be part of the decision-making process as the world's urban areas expand.”

• • •

By Nancy W. Stauffer, MITEI

Development of umi was supported by the MIT Energy Initiative (MITEI) and by the National Science Foundation (NSF), the US Department of Energy, United Technologies Corporation (a Sustaining Member of MITEI), and Transsolar Climate Engineering. Support for the Cambridge solar map came from the city's Information Technology Department and from NSF. A first public version of umi was released in May 2013 during the Symposium on Sustainable Urban Design at MIT (mit.edu/SustainableDesignLab/projects/SustainableUrbanDesignSymposium/

[speakers.html](#)). The symposium was supported by MITEI, the MIT Center for Advanced Urbanism, and the German American Chamber of Commerce Inc. The symposium also hosted the signing ceremony of the Community Compact for a Sustainable Future (see the article on page 43). Further information can be found in:

J.A. Jakubiec and C.F. Reinhart. “A method for predicting city-wide electricity gains from photovoltaic panels based on LiDAR and GIS data combined with hourly DAYSIM simulations.” *Solar Energy*, vol. 93, pp. 127–143, 2013.

C.F. Reinhart, T. Dogan, J.A. Jakubiec, T. Rakha, and A. Sang. *umi—An Urban Simulation Environment for Building Energy Use, Daylighting and Walkability*. Building Simulation 2013 Conference, International Building Performance Simulation Association, Chambéry, France, August 26–28, 2013.

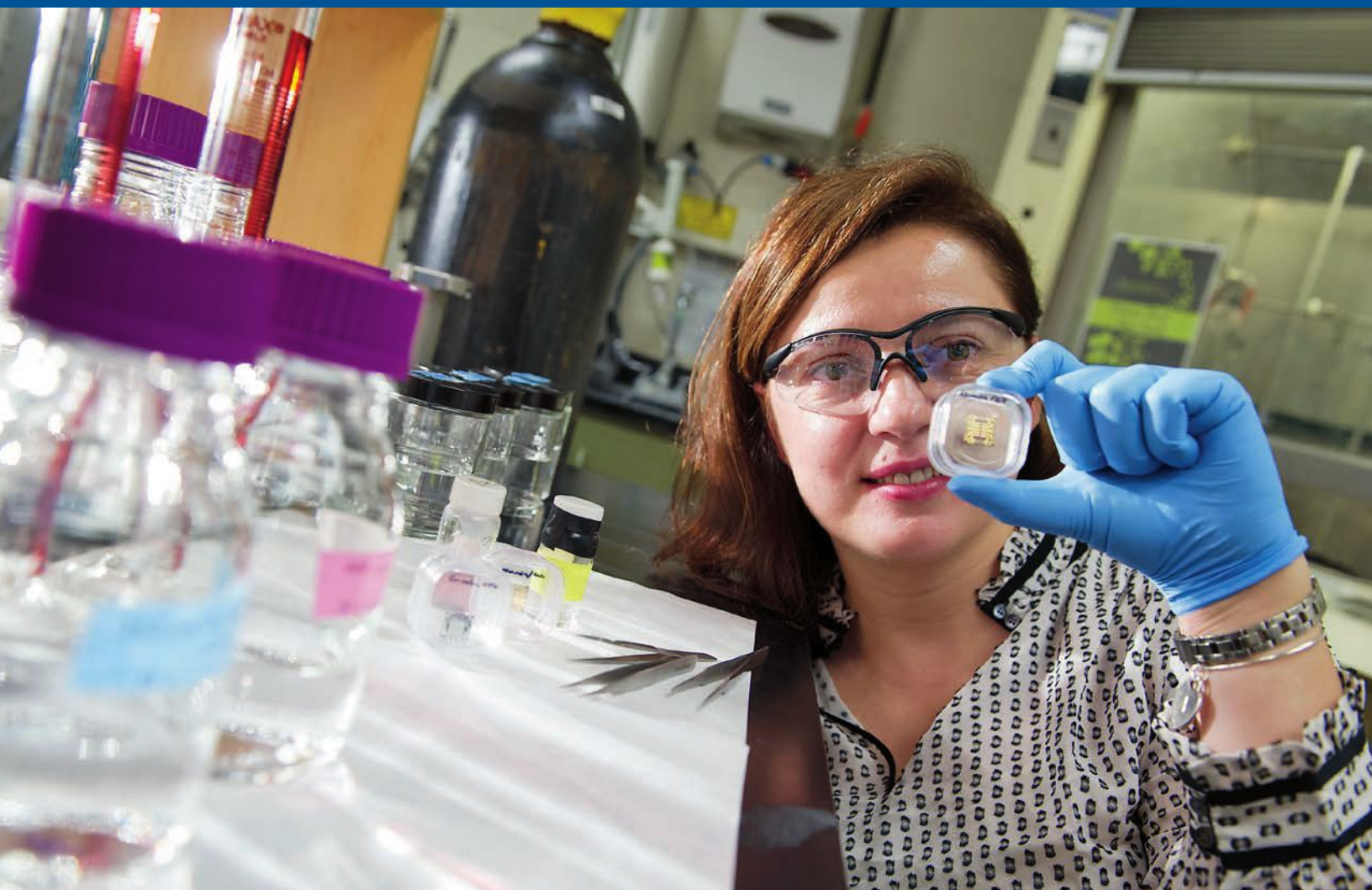

Nanowires and graphene

Keys to low-cost, flexible solar cells

Silvija Gradečak of materials science and engineering and her colleagues have fabricated flexible, transparent solar cells that combine highly conductive microscopic fibers with a robust electrode made of a one-atom-thick form of everyday carbon.

This research was supported by Eni S.p.A. under the Eni-MIT Alliance Solar Frontiers Program. Eni is a Founding Member of the MIT Energy Initiative.

Photo: Stuart Darsch

MIT researchers have made major strides toward developing solar cells that are inexpensive, efficient, flexible, and transparent using a design that combines two special components. Microscopic fibers called nanowires rapidly carry electrons liberated by solar energy through the solar cell to a flexible, transparent electrode made of graphene, a form of carbon that occurs in one-atom-thick sheets. Using a novel approach involving solutions and relatively low temperatures, the researchers were able to attach those two components together, “growing” nanowires directly on graphene in their lab. Tests with assembled solar cells showed that incorporating the nanowires pushed up device efficiency and that there was no performance penalty for replacing a conventional high-cost, brittle electrode with their version made of abundant, inexpensive carbon.

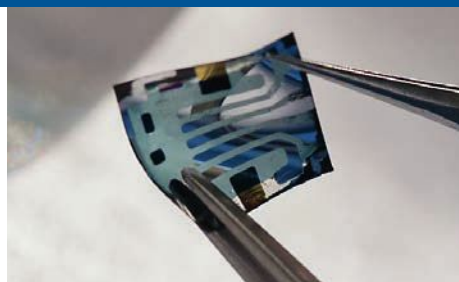

Photo: Stuart Darsch

In the past decade or so, scientists and engineers have begun making photovoltaic solar cells out of organic—that is, carbon-containing—materials rather than inorganic silicon. The potential benefits are many. Conventional silicon solar cells require expensive, meticulous, step-by-step processing and careful handling to be sure they're not damaged during transport and installation. In contrast, organic solar cells can be manufactured using inexpensive, continuous "roll-to-roll" processing in which individual layers are deposited sequentially on large areas of material. The finished organic cells are lightweight, flexible, and transparent, so they're easy to handle and can be installed on roofs, windows, electronic device displays, and other surfaces, both flat and curved.

However, two problems have slowed development of this promising technology. First, organic solar cells can't yet convert visible light into electricity as efficiently as their silicon counterparts can. And second, researchers haven't been able to find a flexible, transparent, low-cost material for the electrode that carries current out of the cell. Silvija Gradečak, the Thomas Lord Associate Professor in Materials Science and Engineering, and a team of collaborators from four MIT departments have come up with methods of dealing with both of those problems.

The efficiency challenge

The challenge with conversion efficiency, says Gradečak, is getting the right geometry inside the organic cell. Any solar cell requires two materials—a "donor" material that absorbs incoming solar energy and gives off energized electrons, and an "acceptor" material that picks up those electrons and carries them to the electrode, where they exit

The new MIT solar cell is both flexible and transparent—and thus suitable for installation on flat or curved surfaces ranging from roofs and windows to electronic device displays.

the device as electrical current. In the usual organic solar cell, two polymers act as the donor and acceptor materials, and they need to be intertwined to provide lots of interfaces for the jumping electrons. The difficulty is controlling the nanometer-scale structure inside the organic cell to achieve those interfaces while providing pathways for the rapid movement of electrons to maximize the current coming out of the device.

To solve that problem, Gradečak has been working to make a "hybrid" solar cell by replacing one of the organic polymers with an inorganic material that will move the electrons more efficiently.

But she adds a special twist: She makes the inorganic material into nanowires, microscopic fibers that are a few billionths of a meter in diameter and millions of times longer. Each nanowire is a single crystal, with an extensive surface area and no defects to interfere with the flow of electrons. And Gradečak's group—the Laboratory for Nanophotonics and Electronics—has an unmatched ability to grow nanowires at any length, diameter, and density desired.

With this approach, there's no need to worry about interconnecting regions of polymers. The electron-donor material can surround a "forest" of tall, solid nanowires—an overall structure that's predictable and stable and maximizes contact between the two materials (see the figure below). Assembling the solar cell involves growing the nanowires up

Incorporating nanowires into solar cells

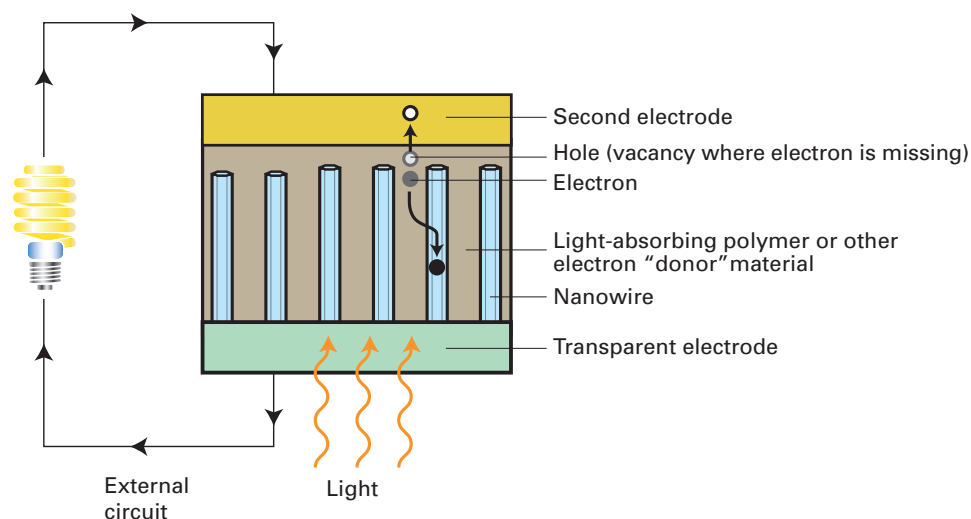

In this solar cell design, tall, thin nanowires grow up from a transparent electrode and are surrounded by a light-absorbing polymer or other electron-donor material. A second electrode tops off the system. Light enters through the transparent electrode and energizes electrons in the polymer. The electrons move into the nanowires and flow to the transparent electrode and then out of the device into an external circuit. After powering, say, a light bulb, the electrons return to the second electrode and rejoin the "holes" they left behind. Using nanowires in place of the usual second polymer increases the stability and predictability of the structure and allows the electrons to move more quickly to the surface of the device.

from a transparent electrode, infiltrating that forest with the polymer or other electron-donor material, and topping it off with a second electrode. When the solar cell is in use, light enters through the transparent electrode, and electrons knocked loose from the donor material move into nearby nanowires. The electrons travel rapidly through the nanowires to the transparent electrode, out along an external circuit, and back to the second electrode.

To test their design, Gradečak and her collaborators grew nanowires on a transparent electrode and then deposited a solution containing the donor material on top. Images with a scanning electron microscope (SEM) showed that the solution infiltrated deep into the nanowire array, making good contact with the nanowire surfaces and leaving few voids to reduce performance. And in experiments with fully assembled devices, the presence of the nanowires pushed up efficiency by as much as 35%, depending on the donor material used.

Those results confirm the viability of their hybrid approach. “By combining the organic and inorganic materials, we bridge the advantages of both worlds,” says Gradečak. “We get solar cells that can be processed at a large scale using roll-to-roll methods, but they can still have reasonable power conversion efficiencies.”

Electrode options

Gradečak envisioned one more improvement, namely, a new material for the transparent electrode. In flexible solar cells now being designed, the transparent electrode is generally made of indium tin oxide (ITO)—not a good choice because it’s fairly brittle and indium is expensive and relatively rare.

Growing nanowires on graphene

Nanowires on conventional indium tin oxide

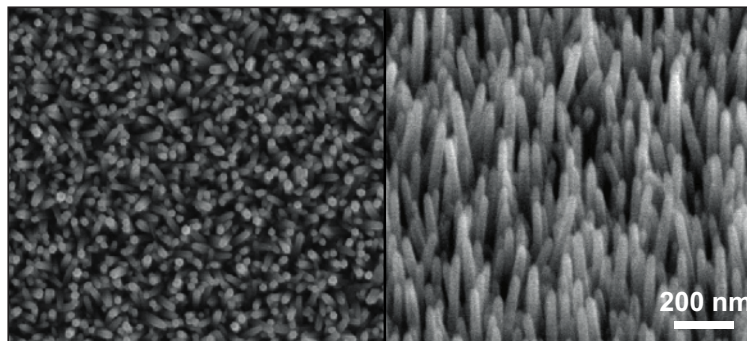

Nanowires on graphene

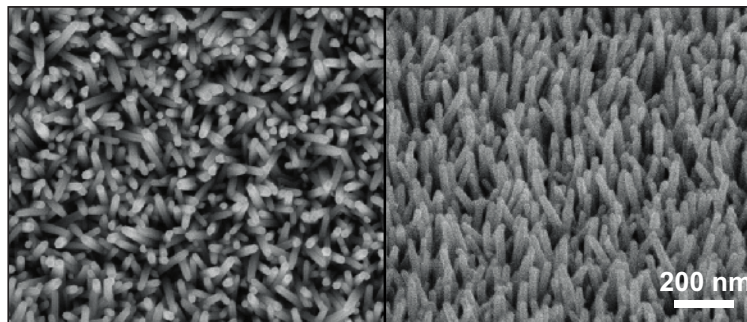

These scanning electron microscope (SEM) images show zinc oxide nanowires grown on indium tin oxide, or ITO (top), the conventional electrode material used in flexible solar cells, and on graphene (bottom), a flexible, transparent form of ubiquitous, inexpensive carbon. To grow nanowires on graphene, the MIT team had to develop a new deposition process that involves first laying down a thin layer of a carefully selected polymer. The SEM images confirm that their approach yields nanowires that are similar in size, shape, and alignment to those grown on ITO, a material that is both costly and brittle.

So Gradečak went looking for a better option.

One material that has recently grabbed the attention of researchers worldwide is graphene, a form of carbon that occurs in one-atom-thick sheets and has remarkable characteristics: It’s not only cheap and abundantly available but also highly conductive, flexible, robust, and transparent. To explore its viability as a transparent electrode, Gradečak teamed up with one of the world’s leading experts on graphene, Jing Kong, MIT’s ITT Career Development Associate Professor of Electrical Engineering and director of the Nanomaterials and

Electronics Group in the Research Laboratory of Electronics.

The first question was whether they could grow nanowires on graphene while preserving the special properties of each component. “It turns out that this is not a trivial thing to do,” says Gradečak. The usual way to grow nanowires made of zinc oxide—their material of choice—is to deposit a “seed” layer of zinc oxide a few nanometers thick on a piece of silicon, ITO, or other substrate and then immerse the structure in a solution containing zinc and oxygen ions. The zinc oxide nanowires quickly grow straight up

Solar cell with nanowires and graphene electrode

from the surface. Because zinc oxide has a crystalline structure, the nanowires grow from individual crystals in the seed layer to form a forest of tall, skinny wires.

But when Gradečak and her colleagues tried to deposit the necessary seed layer on graphene, the zinc oxide solution separated into droplets rather than forming an evenly distributed coating. The problem is that the structure of graphene is extremely stable, with the carbon atoms in each sheet tightly connected with one another in a hexagonal pattern. As a result, graphene repels water, so the zinc oxide solution beads up instead of spreading out. Other researchers have tried to grow nanowires on graphene by first roughening up the graphene surface using an oxygen plasma, but that approach destroys the graphene, and the properties of the nanowires are not well known.

To preserve the integrity of the materials, Gradečak and her team tried a different approach: using an “interlayer” between the graphene and the zinc oxide. They identified two commercially available polymers that would do the trick. The polymers would “wet” the graphene, covering the entire surface with a thin coating on which the zinc oxide could disperse. Better still, the polymers are electrically conductive and chemically compatible with zinc oxide, and they won’t interact strongly with the graphene, so it should remain both transparent and conductive.

To test this approach, the team grew zinc oxide nanowires on graphene with the polymer interlayer and on ITO, the standard transparent electrode material, under identical conditions. The results are shown in the SEM images on page 12. The top images

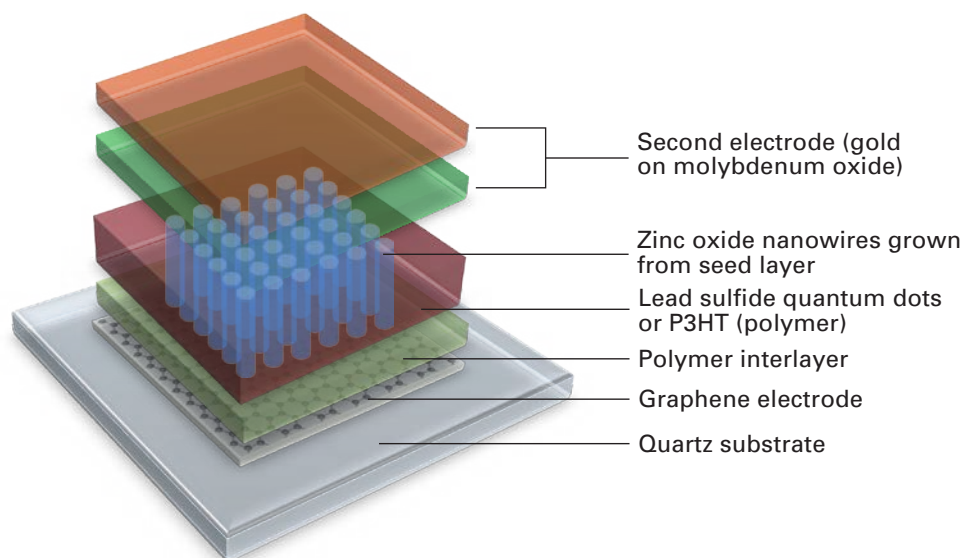

This schematic diagram shows the structure of the researchers’ novel solar cell. A graphene electrode is deposited on a quartz substrate and then covered by a polymer interlayer and a seed layer of zinc oxide. Zinc oxide nanowires grow up out of the seed layer and are infiltrated and covered by either lead sulfide quantum dots or the polymer P3HT. The top electrode is made of gold on top of a thin layer of molybdenum oxide.

show nanowires grown on ITO, viewed from two angles; the bottom images show them grown on graphene with the polymer interlayer. The images confirm that the nanowires grown on the two materials are comparable in their uniformity, shape, and alignment. “So we can grow nanowires on graphene, and the quality of the nanowires is equal to or better than those grown on ITO,” says Gradečak.

The final step was to test the performance of complete solar cells, which team members assembled as shown in the schematic diagram above. First they stacked three monolayers of graphene on quartz, their sample surface. Then they deposited the polymer interlayer followed by the zinc oxide seed layer, the nanowires, the electron-donor material, and finally a second electrode of gold on a thin layer of molybdenum oxide. To test their options, they used this approach to assemble devices with each of their polymer interlayers—called PEDOT and RG-1200—and with two versions of the donor material: a polymer called P3HT and lead-sulfide quantum dots,

which are tiny chunks of light-absorbing material that can be tuned to absorb a wide range of wavelengths of light. For comparison, they grew all the same devices on ITO electrodes.

The figure on page 14 presents sample results from experiments with the quantum dot devices. The curves show how much current can be extracted at different voltages under the standard illumination used in such tests. The red curve shows results when the polymer interlayer is PEDOT, the blue curve when it is RG-1200. The black curve presents data from the device grown directly on ITO. The performance of the devices with the different interlayers is similar to one another and—more significantly—to that of the ITO-based device. In other tests, the devices with nanowires, quantum dots, and graphene electrodes achieved power conversion efficiencies of 4.2%—less than the efficiency of general-purpose silicon cells but competitive for specialized applications.

Gradečak is pleased with those results. “We’ve shown that the polymers we

Performance of devices made with nanowires and quantum dots on graphene and ITO electrodes

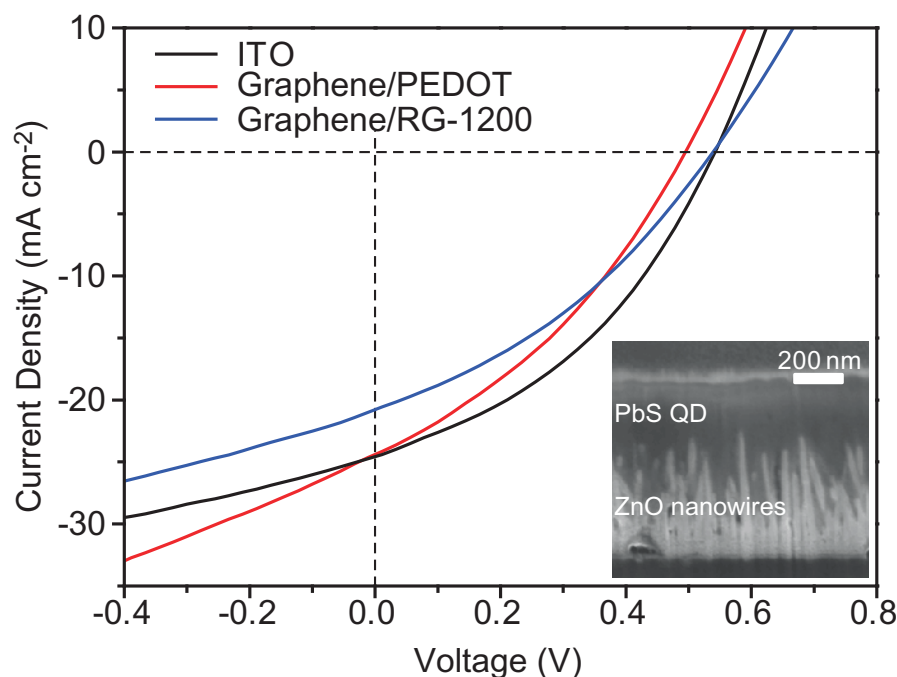

This diagram presents results from experiments with devices made with zinc oxide nanowires and lead-sulfide quantum dots. The red and blue curves show results from devices grown on graphene electrodes with a polymer interlayer of PEDOT and of RG-1200, respectively. The black curve shows results from a device grown directly on an ITO electrode. Measurements of current extracted at differing voltages are similar for all three devices, confirming the viability of using the inexpensive graphene electrode without sacrificing device performance.

use to make devices on graphene don't interrupt the flow of electrons out of the device," she says. "Our results show that we can replace the ITO electrode with graphene without sacrificing device performance." Moreover, their simple low-temperature, solution-based method of depositing nanostructured materials on graphene without altering its structure or properties may be useful in fabricating novel versions of other optoelectronic devices, such as light-emitting diodes, lasers, and photodetectors.

The researchers are continuing to improve the performance of their solar cells, for example, by optimizing the

size and spacing of the nanowires to maximize surface area, the amount of infiltrated electron-donor material, and the interface between the two. And they're beginning to assemble their devices on other surfaces, including aluminum foil and lightweight plastics. "In our graphene-based solar cells, all the active components—the nanowires, polymers, and quantum dots—as well as the electrodes are flexible," says Gradečak. "We're now beginning to deposit them on flexible substrates, and that's extremely exciting."

• • •

By Nancy W. Stauffer, MITEI

This research was supported by Eni S.p.A. under the Eni-MIT Alliance Solar Frontiers Program. Eni is a Founding Member of the MIT Energy Initiative. Further information can be found in:

H. Park, S. Chang, J. Jean, J.J. Cheng, P.T. Araujo, M. Wang, M.G. Bawendi, M.S. Dresselhaus, V. Bulović, J. Kong, and S. Gradečak. "Graphene cathode-based ZnO nanowire hybrid solar cells." *Nano Letters*, vol. 13, pp. 233–239, 2013.

J. Jean, S. Chang, P.R. Brown, J.J. Cheng, P.H. Rekemeyer, M.G. Bawendi, S. Gradečak, and V. Bulović. "ZnO nanowire arrays for enhanced photocurrent in PbS quantum dot solar cells." *Advanced Materials*, vol. 25, pp. 2790–2796, 2013.



Incentives for green technology adoption

Getting government subsidies right

Georgia Perakis of the MIT Sloan School of Management has developed a model that will help government decision makers set optimal subsidies to encourage the adoption of a green technology, taking into account the probable responses of suppliers and buyers of the new technology.

This research was supported in part by a seed grant from the MIT Energy Initiative. More details on funding sources appear on page 19.

Photo: Justin Knight

To encourage the adoption of green technologies, some governments are providing subsidies to consumers who buy solar panels, electric vehicles, and the like. A new MIT model can help policy makers determine the level of subsidy needed to meet a future technology adoption target at minimal cost. For any target, the model calculates the government's optimal subsidy and the technology supplier's optimal production quantity and selling price (for maximum profit). Critical to the optimization process is a prediction of consumer response based not only on the price and rebate but also on factors such as environmental values and familiarity with the technology. Analyses show that meeting the target requires recognizing the full range of possible demand outcomes—and the more uncertain the future demand, the better the deal for consumers will be.

When governments offer consumer subsidies on green technologies, the goal is generally to achieve some critical level of demand that will serve to bring down prices, encourage product improvements, establish wider familiarity, and ensure a continuing stream of future customers. But setting a subsidy that will elicit the desired response while minimizing government expenditures is difficult. Part of the problem is that policy makers don't know in advance how consumers will respond to a given subsidy. They also don't know how suppliers of the green technology will behave. Although the subsidies are paid directly to consumers, suppliers will take them into account as they decide on future production quantities and sales prices—and like the policy makers, the suppliers must make their decisions without knowing how consumers will respond.

“Policy makers cannot develop effective subsidy programs for green technologies without a clear understanding of what drives consumers to adopt the technologies and companies to invest in them,” says Georgia Perakis, the William F. Pounds Professor of Operations Management and Operations Research/Statistics. To help policy makers—and suppliers—make the best decisions they can, she and her co-workers developed a model that describes consumer behavior and created a comprehensive framework that examines supplier decision making and then optimizes subsidies for a range of adoption targets.

Modeling consumer demand

To begin their investigation, Perakis and Ruben Lobel PhD '12—now an assistant professor at the Wharton School of the University of Pennsylvania—developed a model of the adoption of

rooftop solar photovoltaic panels by residential consumers. The model tracks the decision by every household to purchase or not purchase solar panels, taking into account the rebate offered by the government. However, the model doesn't simply assume that as price goes down, demand goes up in a regular, predictable fashion. Instead, it takes into account a variety of other factors. For example, the “utility” to the consumer of buying solar panels comes not only from the sale of electricity but also from the social value of being environmentally friendly. The consumer's decision is affected by “information spread.” (If your neighbor buys the technology, you'll be more likely to buy it.) And the cost of installation is not constant but decreases as the number of installations increases. Based on that consumer model, Perakis and Lobel developed a tool that calculates optimal subsidies to achieve a desired adoption target while minimizing government expenditures on consumer rebates.

To validate their model, Perakis and Lobel performed an empirical study of the solar market in Germany. First they gathered historical and projected data on numbers of households, their electricity bills, and other relevant information as well as details about solar installations between 1991 and 2007 (size, installation cost, average electricity yield, and so on). They then forecast annual solar installations out to 2030. Using the policy optimization tool, they determined the optimal subsidy for meeting possible adoption targets and the costs incurred.

Their results show that the subsidy program now in effect in Germany is not economically efficient. There exists a way to reach any target at a lower overall cost. The key is in the timing of the subsidies. “Our analysis suggests

that German policy makers should increase current subsidies and then phase out future subsidies at a faster rate,” says Perakis. “They'd be able to spend less and still achieve the same target adoption levels.”

Other players in the game

The next step is to understand how suppliers respond when the government establishes a subsidy program. To describe the government-supplier interaction, Perakis turns to game theory. In “Stackelberg competition,” there are multiple players in a system who are not coordinated. Instead, each entity acts “selfishly,” and one of the players always moves first. So you have sort of a game, explains Perakis. As shown on page 17, in this game, the government acts first, setting the subsidy. Suppliers then follow, each one making its own decisions about pricing and production levels—with the subsidy program in mind.

While there are theoretical models for “solving” a Stackelberg game, in this case there's an added complication: the consumers. Both the government and the suppliers must make their moves without knowing what consumers will do. So from their perspective, future demand is uncertain. Based on their experience, they can predict some average future demand. But in reality there's a range of possible levels of future demand—both higher and lower than that average—and there's a certain probability that each of those levels will actually occur.

Perakis, Lobel, and Maxime Cohen, a graduate student in the MIT Operations Research Center and a Shell-MIT Energy Fellow for 2011–2012, have made a model of the system that can take into account that demand uncertainty. The

**Subsidies for green technology adoption:
Modeling market dynamics as a Stackelberg game**

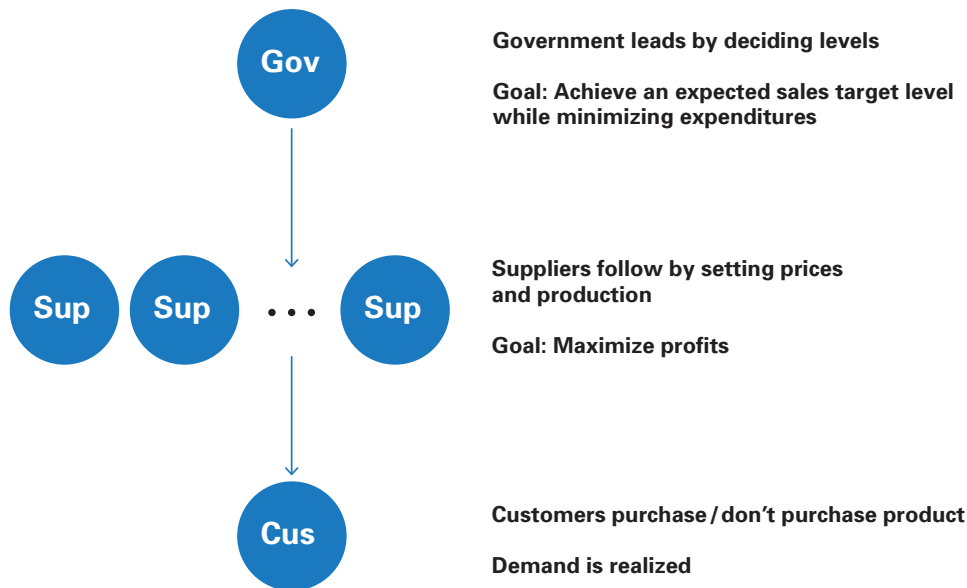

Thus, a subsidy based on average demand will be too low; the government will not achieve its targeted adoption level.

Indeed, the impact of including demand uncertainty is evident in all the theoretical results: Optimal subsidies are higher, government expenditures for consumer rebates are higher, the quantities manufactured by suppliers are higher, and prices and supplier profits are lower. Each of those results improves the situation for the consumer—at the expense of government and industry. And the greater the uncertainty in demand—that is, the wider the variability—the more consumers will benefit.

To test those results, the team performed a case study of GM's Chevy Volt. They based their analysis on the first 18 months (December 2010–June 2012) of sales data for the Volt. The figure on page 18 shows the optimal subsidy, production level, supplier profit, and government expenditure for meeting various targets as calculated based on average demand (blue) and on uncertain demand (red).

Again, results from calculations based on average demand overestimate consumer response. As an example, consider a target of 3,500 electric vehicles. By the average method, the optimal subsidy to get that number of electric vehicles on the road is \$7,500. But taking into account uncertainty, the optimal subsidy for that target is about twice as high. Likewise, the average calculation undershoots the optimal production, though not by much. And it overestimates industry profits and underestimates government expenditures. Those gaps are evident at all targets, and the spread increases as the target gets higher. Calculations

model assumes that government aims to reach its target while minimizing expenditures and that suppliers simply seek to maximize their profits. (Those assumptions can be changed.) The model then calculates for each target level the optimal subsidy for government to offer and the optimal production and price for suppliers to set—assuming that consumers respond to those decisions as calculated by the demand model. That calculation can either assume an average consumer demand, or it can explicitly recognize the uncertainty of consumer demand, taking into account the full distribution of possibilities.

Impacts of demand uncertainty

To better understand the dynamics of the system, the researchers used their model to perform theoretical studies of

how various assumptions and choices can influence outcomes. One question relates to the impact of including or excluding demand uncertainty from the decision-making process. "Right now, government and industry typically look at what consumer demand is on average and then determine their policies based on that average demand," says Perakis. What does ignoring demand uncertainty mean for participant behavior—and for the likelihood that government will meet its technology-adoption target?

To find out, the team determined optimal choices for government and industry, first based on average consumer demand and then on the full spread of possible levels of demand. The analysis showed that calculations based on average demand will always overestimate the demand response.

**Optimal government and supplier choices at various technology adoption targets:
Case study of GM's Chevy Volt**

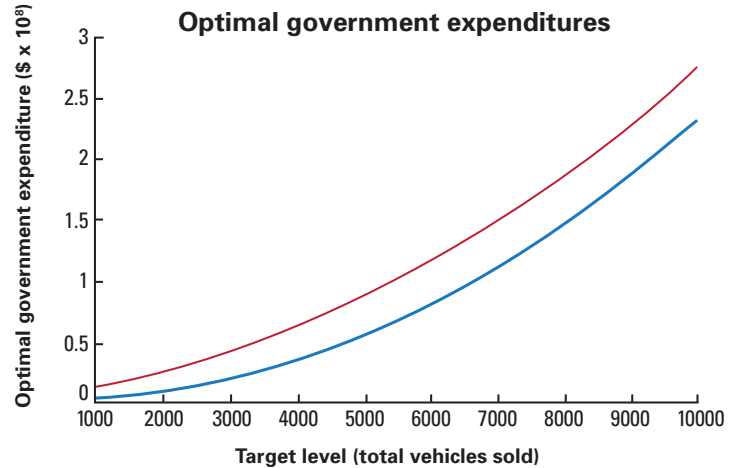
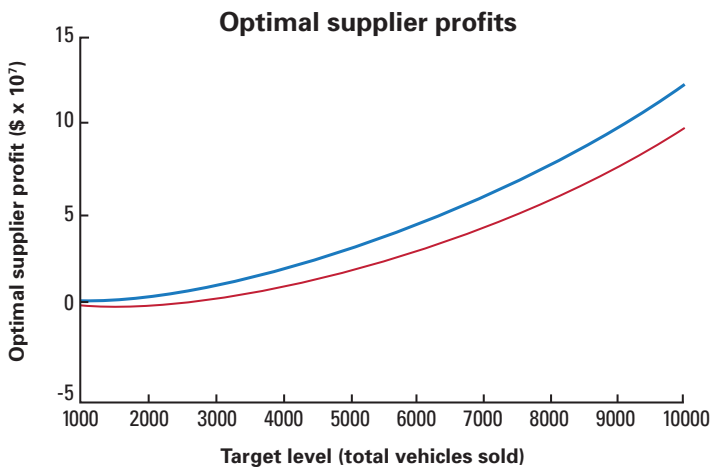
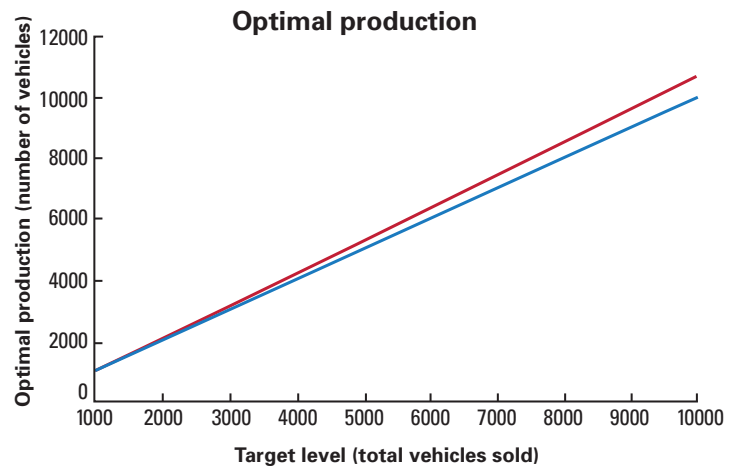
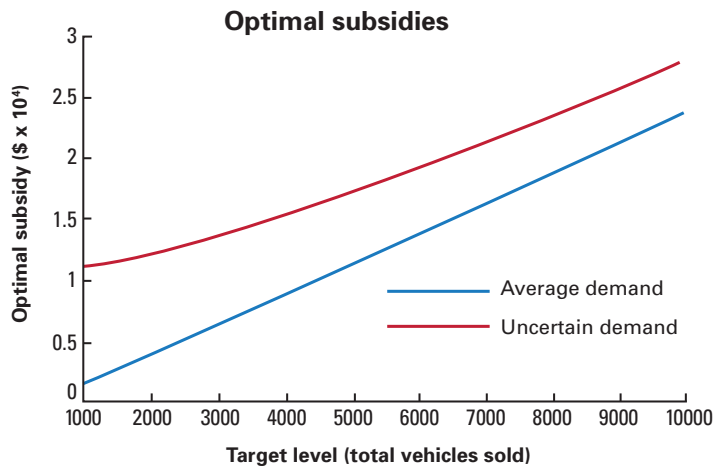

Results from a case study of GM's Chevy Volt, using sales data from December 2010–June 2012. In setting the subsidy, government aims to meet a technology adoption target at minimal cost; in responding, suppliers seek to maximize their profits. The blue curves show optimal subsidies, production levels, supplier profits, and government expenditures calculated based on average predictions of future consumer demand. The red curves show the same values resulting from calculations that explicitly account for the uncertainty in future demand. When uncertainty is included, subsidies, production, and government expenditures are higher, and supplier profits are lower at all target levels.

based on various levels of uncertainty show that the spread between the results increases as demand becomes more uncertain. The quantitative results are thus in line with the theoretical findings. “And at the end of the day, the net of what the consumer will pay—the price minus the rebate—will be less,” says Perakis.

Changing the assumptions

Those analyses provide some insights into why current subsidy programs may not work as planned and how governments might do better. In addition, Perakis performed analyses based on different assumptions, and some yielded results that she deemed “surprising.” Here are a few examples.

- Instead of trying to minimize expenditures while meeting the target, government could aim to maximize the total welfare of the system—that is, the well-being of consumers and suppliers as well as government. Assuming that government pursues this more idealistic goal doesn’t significantly alter the results. “So when government goes for low expenditures, welfare doesn’t do too badly anyway,” says Perakis.
- Another possibility is that government and suppliers could work together, for example, if government owned the industry involved. How would consumers fare then? According to the analysis, the cost to the consumer—the price minus the rebate—would actually be the same, as long as government’s goal is to meet the target. A possible explanation: When government and suppliers operate independently, the subsidy serves as a mechanism that coordinates their decision making.
- Government will probably make its decisions based on average demand. But suppliers might use sophisticated models that take uncertainty into account. What then? A numerical analysis based on the Chevy Volt data shows that in that situation, average sales would be well below the government’s target.
- In establishing a multi-year program, government can set a subsidy for the full period, or it can set one subsidy for the first year, another for the second year, and so on. The latter approach might seem preferable because government can update the subsidy based on the previous year’s experience. The researchers’ calculations show that the “flexible” approach is more expensive on average, but there will be less variability in the demand that results.

Perakis and her team continue to gather insights into the factors that determine how subsidies play out. However, she stresses that the real goal of their work is to provide practical tools for designing successful programs for encouraging green technology adoption. She believes that their novel research approach “could have a significant impact on society as policy makers start using these tools and insights to make their strategic decisions about future subsidies.”

• • •

By Nancy W. Stauffer, MITEI

Development of the consumer demand model and the German solar market case study were supported by a seed grant from the MIT Energy Initiative (MITEI). Formulation of the comprehensive decision-making framework was supported by a MITEI seed grant as well as by the National Science Foundation. Further information can be found in:

M. Cohen, R. Lobel, and G. Perakis. “Designing consumer subsidies with industry response for green technology adoption.” Extended abstract in *Manufacturing and Service Operations Management (MSOM) Conference Proceedings*, Columbia University, June 2012. Full article forthcoming.

M. Cohen, R. Lobel, and G. Perakis. “Designing subsidies with industry response dynamics: commitment vs flexibility.” Extended abstract in *MSOM Conference Proceedings*, INSEAD, Fontainebleau, France, June 2013. Full article forthcoming.



Fine-tuning porous materials for energy-efficient air conditioning

Much attention is focusing on special crystalline structures that contain tiny pores ideal for storing important materials such as carbon dioxide, hydrogen, and water vapor. But so far they are not widely used because they collapse when exposed to even a little moisture. Now, an MIT chemist has developed novel versions of these porous “frameworks” that can actually soak in water for days with no harm done. His frameworks are made from inexpensive, easy-to-assemble molecular building blocks, and they can be fine-tuned for various functions, including adsorbing water at variable levels of humidity—a good feature for energy-efficient systems designed to cool indoor air. He’s now working to maximize the amount of water stored, and he’s looking at other applications ranging from desalination systems and battery materials to gas separations and catalysis.

Mircea Dincă of chemistry has developed inexpensive, highly porous materials that are ideal for storing large quantities of water vapor picked up by air conditioners, carbon dioxide captured from power plants, and hydrogen fuel stowed onboard cars.

This research was supported by a seed grant from the MIT Energy Initiative (MITEI) and by BP Technology Ventures Inc., a Founding Member of MITEI. For more details on funding, see page 24.

Photo: Justin Knight

In the search for energy savings, a good place to look is at buildings. In the United States, running buildings uses almost 75% of all electricity consumed and generates about 40% of all carbon dioxide emitted. Air conditioners alone use almost 7% of that electricity, which translates into fully 5% of total national consumption. “If we could make air conditioners more energy efficient, that would put a huge dent in our energy consumption and carbon emissions,” says Mircea Dincă, assistant professor of chemistry.

Instead of using environmentally unfriendly refrigerants and inefficient cooling cycles, Dincă asks us to “reimagine air conditioners using high-surface-area adsorbents” to help relocate unwanted heat. He notes that this idea isn’t new with him and his research group. “Where we come in,” he says, “is making new materials that can adsorb water more efficiently and in much higher concentration than ever before.”

His work focuses on the heat pump, a device that moves heat from indoors to outdoors (or depending on the design, vice versa) using little energy and an environmentally benign working fluid such as water. In the optimal design, the heat pump is made up of two boxes connected by hoses. One box is inside the house and partially filled with water; the other is outdoors and contains a porous material. To start out, the water in the indoor box evaporates, taking heat out of the household environment in the process. Pressure builds up, and the water vapor flows to the outdoor box. There, it’s adsorbed into the porous material, releasing its heat to the outdoor atmosphere. Aided by a bit of energy—preferably from a renewable source—the water is then condensed and pumped back to the indoor box to

Possible MOF structures



1-D frameworks (chains)

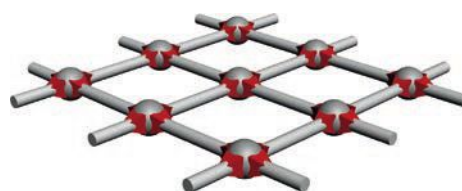

2-D frameworks (layers)

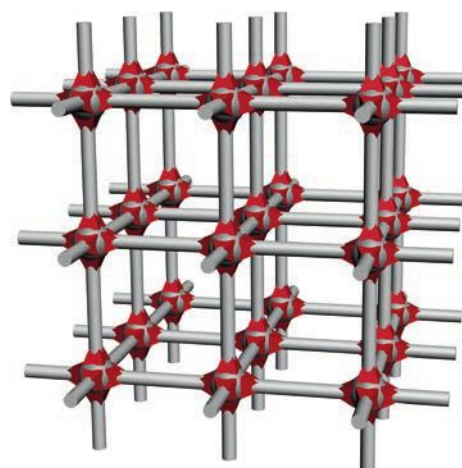

3-D frameworks (grids)

Metal-organic frameworks, or MOFs, are structures made from metal nodes connected by organic (carbon-containing) linkers, or “ligands.” As shown here, MOFs can take the form of 1-dimensional chains, 2-dimensional layers, or 3-dimensional grids. In the 3-D form, they can be highly porous, with abundant open spaces where atoms and molecules can cling onto internal surfaces, providing extraordinary storage space for gases and vapors.

start the cycle again. Carefully timed valves open and close to ensure that the flow goes the right way and is as continuous as possible.

This energy-efficient, environmentally friendly device can remove heat in

homes, in office buildings, and even in big factories that need large-scale heat mitigation. But today’s heat pumps do not perform as well as they could, according to Dincă. What’s needed is a porous material with a far higher internal surface area. Molecules like to cling to surfaces. Fill an empty cylinder with a porous material, and the molecules will cling onto all the interior surfaces of the pores—nearer to one another than they would be in the empty cylinder. The more porous the material, the higher the internal surface area and the more sites the molecules have to cling to.

With heat pumps, replacing the current adsorbent with a more porous one could significantly improve performance. Work toward that end has focused on zeolites, materials that look like rocks but actually contain tiny channels, each about 1 nanometer wide—not unlike the dimensions of a molecule. Zeolites are widely used in industry, for example, as catalysts in gasoline production and as adsorbents in detergents. But their uses are limited because they’re not very “tunable.” They’re composed of silicon, aluminum, and oxygen, so it’s hard to change their composition, structure, or properties to suit a particular application.

Introducing the MOF

Attention has therefore focused on porous structures called metal-organic frameworks, or MOFs. These structures are built of metal nodes connected by “ligands” made of organic (carbon-containing) molecules. As shown in the diagram at the left, they can be 1-dimensional chains or 2-dimensional layers or 3-dimensional frameworks with varied shapes, which present empty channels where gases or vapors can be stored.

MOFs are almost endlessly tunable because their composition isn't set. "Instead of just silicon, aluminum, and oxygen, MOFs can be made from pretty much any element of the periodic table. You can mix and match," says Dincă. "Now the possibilities in terms of structure and function are virtually endless."

Researchers worldwide are working to take advantage of the many remarkable features of MOFs, but what started all the excitement, notes Dincă, was their surface area. "MOFs have the highest surface areas of any known materials," he says. "If you could unfold all the material in a single gram of MOF, you'd get 5,000 square meters of surface area—enough to cover an entire football field." That's five times more

area than offered by the best zeolites and represents significant storage capacity for important applications. For example, a cylinder filled with a MOF can hold twice as much hydrogen or nine times as much carbon dioxide (CO₂) as it can when it's empty. The implications for designing fuel tanks for hydrogen cars or temporary storage systems for CO₂ captured from power plants are significant.

MOFs would seem the ideal porous material for a highly efficient heat pump—except for one problem: MOFs break down when they're exposed to water. Indeed, MOFs are so sensitive that even a brief exposure to atmospheric moisture causes the complete decomposition and collapse of their porous structure. As a result,

promising MOF-based technologies now being developed for hydrogen and carbon storage—as well as for catalysis, gas separations, and other industrially important processes—haven't yet been deployed.

Adding water resistance

To tackle the water sensitivity problem, Dincă and his team decided to explore novel MOF compositions. They focused on the weakest link within any MOF: the piece of the organic ligand that links to the metal node. The typical connector—a carboxylic acid—makes that link via a metal-oxygen bond, which is unstable in water. The MIT team decided instead to try pyrazoles, which are five-member rings of carbon and nitrogen atoms. Nitrogen atoms in

Water stability of pyrazole-based MOFs

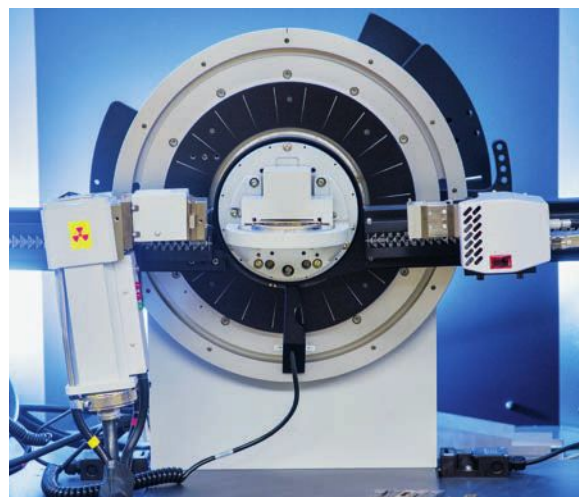
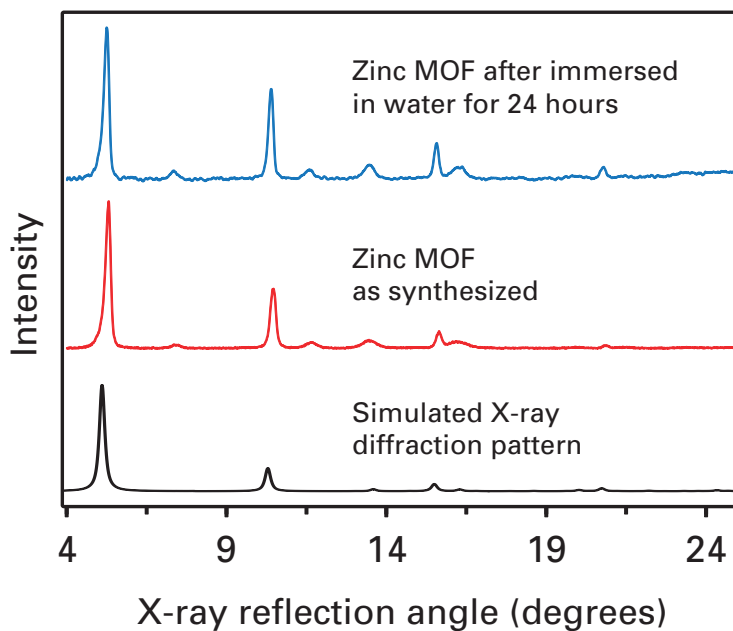
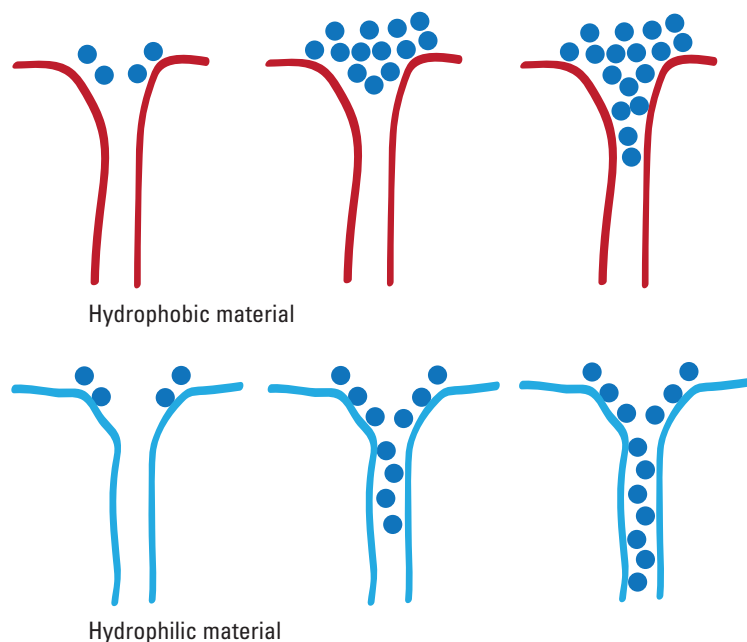

Photo: Justin Knight

To test for water stability, the researchers synthesized samples of their MOFs with zinc and then immersed some of them in water. The curves at the left show X-ray diffraction patterns from tests in the machine shown in the photo using a dry sample (middle) and a sample that had been immersed for 24 hours (top) as well as a simulated diffraction pattern representing a zinc MOF not exposed to water (bottom). In all three curves, the peaks occur in the same locations, indicating that the structure of the sample was not changed by spending a day in water.

Effect of water affinity on water adsorption behavior



These diagrams show water molecules arriving at the opening to a pore in a water-hating (red) and water-loving (blue) material. In the former, many water molecules accumulate at the surface before any enter the pore. In the latter, the water molecules readily enter the pore as soon as they arrive, never accumulating on the surface. This effect explains why higher pressure—thus higher relative humidity—is needed before water adsorption begins in a water-hating material.

Effect of altering water affinity on water adsorption

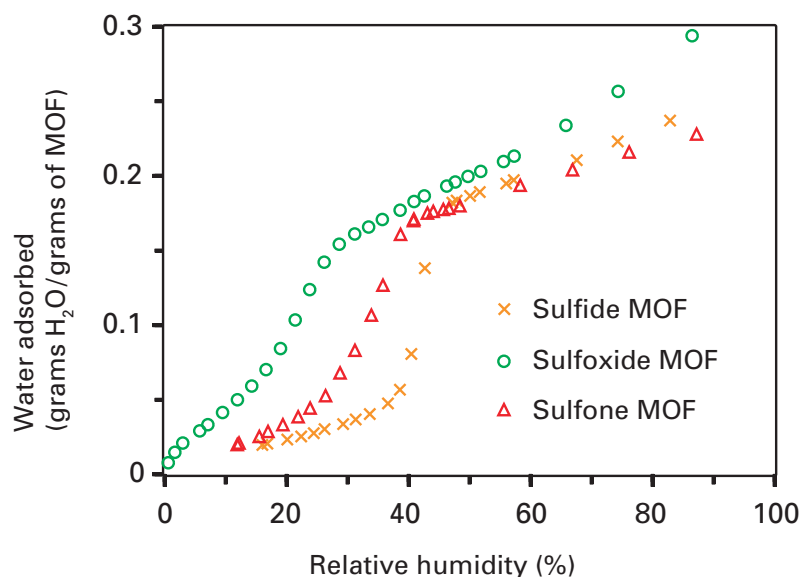

These curves show the effect of altering water affinity on water adsorption by MOFs. The sample with a water-hating sulfide group added to the pore surface (the orange curve) shows little water adsorption until the relative humidity reaches about 50%. The addition instead of sulfoxide or sulfone groups—both water-loving sulfur-oxygen combinations—moves the rapid rise in adsorption down to a relative humidity of about 20%. These results confirm the importance of water affinity when designing a MOF for high-performance heat pumps or other water-adsorption devices.

pyrazoles bond far more strongly with metals than oxygen atoms do, so the resulting MOF should be more stable to water as well as to heat.

In practice, however, working with pyrazoles is tricky. “People knew that pyrazole-based MOFs were water-stable, but it was difficult to make them on a large scale,” says Dincă. “They’re just synthetically challenging to make.” To get around that problem, the MIT researchers devised a method of making their ligand using a form of naphthalene—an abundant, inexpensive material—and then adding on the pyrazoles at the end of the synthesis. “So we don’t have to worry about the synthesis of the pyrazole itself,” says Dincă. “With naphthalene as a repeating core, we can synthesize MOFs from pyrazole-based ligands and various metals easily, inexpensively, and at large scale. That’s important if we’re going to put a box of these in every household.”

The next step was to see if the MOFs could stand up to water. They synthesized samples with zinc—a benign metal—and immersed some of them in water. The diagram on page 22 shows the X-ray diffraction patterns of a soaked and a dry sample as well as a simulated pattern representing a pristine zinc MOF. The three curves show peaks at the same locations, indicating that the atoms are all in the same positions and the structure is unchanged by the soaking. While other MOFs lose their crystal structure at the slightest sign of moisture, the MIT ones can withstand being soaked—and even boiled—in water.

However, in other tests, the new water-resistant MOFs exhibited another problem: They don’t start adsorbing water until the relative humidity at their

surface reaches 40%–50%. In that case, adsorption will begin only after significant evaporation and vapor buildup have occurred inside the heat pump. Given those limitations, the device won't start operating until the temperature in the room is unacceptably high.

Close examination of the MOFs showed the problem: Their channels are of desirable dimensions, but their interiors are hydrophobic—"water hating"—and therefore reluctant to adsorb water, as the top figure on page 23 demonstrates. The upper drawing shows a pore in a hydrophobic material. As water molecules arrive, they bunch up, entering the pore only after many have accumulated. As a result, adsorption begins only when the relative humidity is high. In contrast, the lower drawing shows the situation in a hydrophilic, or "water loving," material. Now the arriving water molecules slide readily into the pore. There's no need for them to accumulate, so adsorption begins when humidity is low.

To adjust the adsorption behavior of their MOFs, the MIT team decided to try changing the surface composition of the pores. They synthesized samples and then "decorated" the inside surfaces of the channels with atomic groups with well-documented affinities for water—some positive and some negative. They then tested the relative humidity at which the samples started to adsorb water.

The results are shown in the bottom figure on page 23. The orange curve shows the effect of adding sulfide, which is hydrophobic. Significant water uptake doesn't begin until the relative humidity reaches almost 50%. The green and red curves show the impact of adding sulfur plus one or two atoms

of oxygen—molecules that are hydrophilic. Now the rapid rise in adsorption begins at a relative humidity as low as 20%. Calculations show that at this adsorption threshold, their MOF should start removing water at temperatures appropriate for indoor air conditioning.

Making better MOFs, exploring new uses

The MIT researchers are continuing to improve their MOFs for use in heat pumps and other water-adsorbing devices. They are now working to increase the surface area so as to increase the amount of water that a MOF of a given dimension can hold. Their current "water loading" is acceptable, but they plan to make it far better, thereby reducing the amount of adsorbent material needed in a high-efficiency heat pump.

They are also developing designs in which metal blades run through the MOF in the outdoor box of the heat pump to help transfer the heat—a challenge in a material with so much void space. To that end, they have developed a controlled method of depositing MOF coatings on surfaces using electrochemistry. With this technique, they can make high-quality coatings on any conductive surface in 15 minutes at room temperature rather than 24 hours at 100°C, as required by conventional deposition methods.

By combining their abilities to deposit MOFs as high-quality coatings and to tune them for specific functions, Dincă and his team are now exploring novel approaches not only for air conditioning but also for gas separations, CO₂ capture and storage, efficient and selective catalysis, desalination, and even novel MOF-based solar cells.

Says Dincă, "MOFs could be the wonder material that solves every problem. Now will they actually do that?" He and his team are working hard to find out.

• • •

By Nancy W. Stauffer, MITEI

Research on MOFs for adsorption-based heat pumps was supported by a seed grant from the MIT Energy Initiative (MITEI). Research on the deposition of MOFs on conductive surfaces was performed as a BP Technology Ventures Inc.–supported research project within MITEI. BP is a Founding Member of MITEI. Dincă is now forming a startup company to develop and market commercial products based on his novel materials, including "drop-in" replacement adsorbent components that will decrease the size and capital costs of current engineering designs for commercial adsorption chillers. Further information can be found in the following:

C.R. Wade, T. Corrales-Sanchez, T.C. Narayan, and M. Dincă. "Postsynthetic tuning of hydrophilicity in pyrazolate MOFs to modulate water adsorption properties." *Energy & Environmental Science*, vol. 6, pp. 2172–2177, 2013.

M. Li and M. Dincă. "Reductive electro-synthesis of crystalline metal–organic frameworks." *Journal of the American Chemical Society*, vol. 133, pp. 12926–12929, 2011.

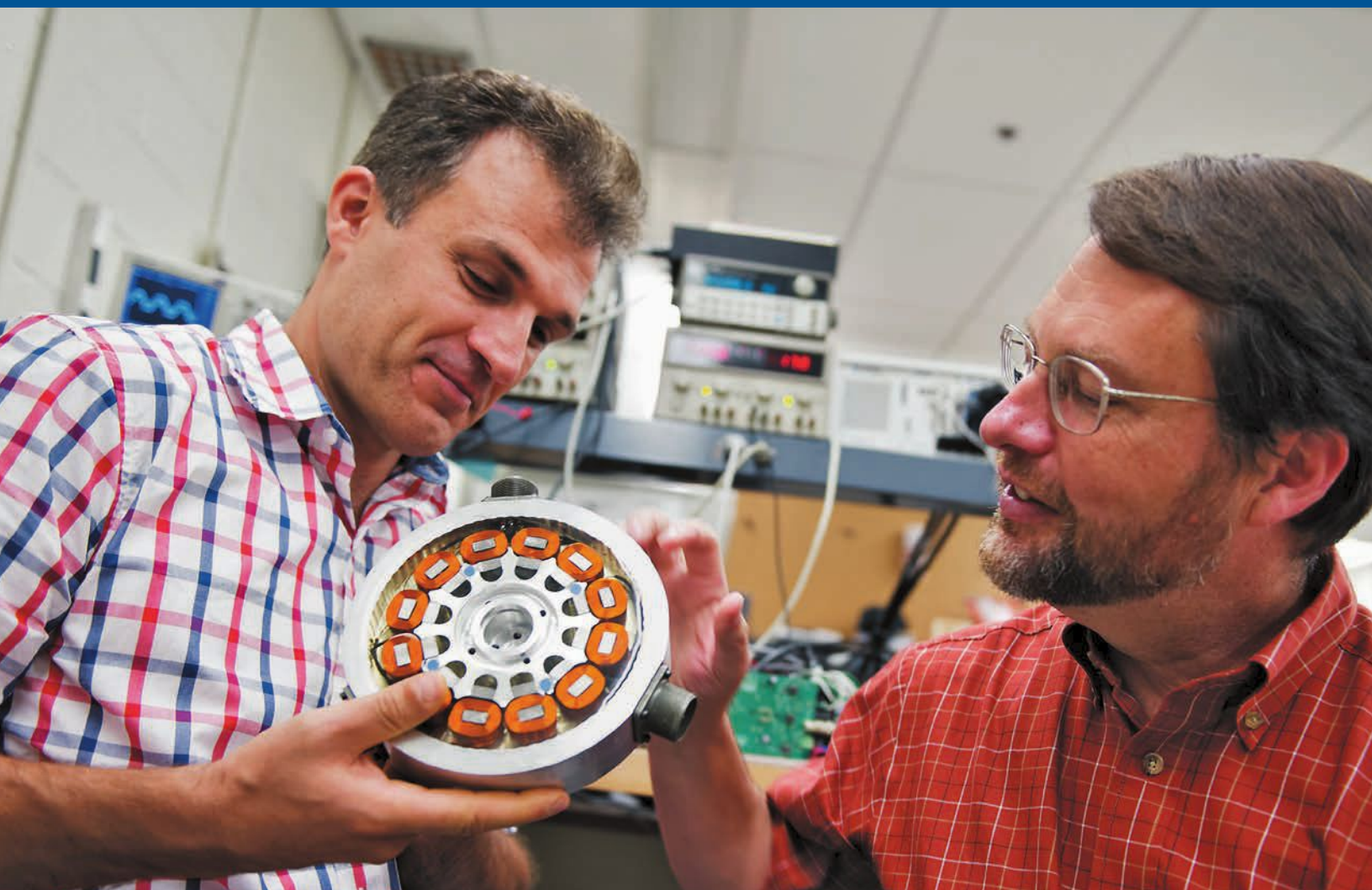

Designing high-speed motors for energy storage and more

Mohammad Imani-Nejad PhD '13 of the Laboratory for Manufacturing and Productivity (left) and David L. Trumper of mechanical engineering are building compact, durable motors that can operate at high speeds, making devices such as compressors and machine tools more efficient and serving as inexpensive, reliable energy storage systems.

This research was supported in part by a seed grant from the MIT Energy Initiative. See page 29 for more funding details.

Photo: Stuart Darsch

Devices from compressors to flywheels could be revolutionized if electric motors could run at higher speeds without getting hot and failing. MIT researchers have now designed and built novel motors that promise to fulfill that dream. Central to their motors are spinning rotors of high-strength steel with no joints or bolts or magnets. Rather than resting those rotors on vulnerable bearings, the researchers levitate them by manipulating the steel's natural magnetic "memory" to control the magnetic fields inside the device. Their contact-free designs are compact, efficient, and suited to low-cost manufacturing as well as high-speed operation. One motor is specially designed as a high-velocity flywheel for reliable, fast-response energy storage—a function that will become increasingly important as electric power systems become more reliant on intermittent energy sources such as solar and wind.

As the world looks to limit greenhouse gas emissions, carbon-free renewable energy sources such as solar and wind will play a growing role on power grids. But such sources cannot generate electricity all the time. According to David L. Trumper, professor of mechanical engineering, a good way to smooth out supply would be using a high-performance version of an old energy-storage device: the flywheel. When sunshine and wind are abundant and electricity is plentiful, some power would be diverted into making the flywheel spin. When the sun sets or the wind dies down, the flywheel would be allowed to decelerate, running a generator that feeds electricity into the power system to fill the gap. The stored energy could also be used to meet occasional peaks in electricity demand—a far less expensive approach than the current practice of maintaining “peaking plants” that run only as needed. Flywheels are environmentally benign, quick to respond, long lasting, and insensitive to temperature changes. But they perform best when they turn at extremely high speeds—as do machines ranging from generators, compressors, and turbines to precision machine tools. What’s needed is a motor that can run safely and reliably with its rotor surface moving at several times the speed of sound.

Steps in the right direction

Designing a motor to turn electricity into movement is tricky. In a typical motor, a component called a rotor turns inside a stationary component called a stator. One of those components contains permanent magnets that have south and north poles. The other has wire coiled around it. Putting electricity through the coils creates magnetic fields that attract and repel the poles of the permanent magnets. That

interaction causes the rotor to turn. Keeping it spinning requires constant changes in the magnetic fields. As Trumper explains, “The coil current has to vary in time so as to create moving magnetic fields that create the forces you want in the directions you want” to rotate the rotor.

In a conventional brushed direct-current motor, the magnets are in the stator and the coils go around the rotor. The rotor is supported by a pair of mechanical bearings. But those bearings tend to wear out—especially when the rotor spins quickly. So about 20 years ago, researchers developed a “self-bearing motor.” They moved the coils from the rotor onto the stator and the permanent magnets from the stator onto the rotor. By controlling the magnetic field from the stator, they could both levitate and turn the rotor. In this design, the entire motor consists of just the rotor plus the stator—no bearings needed. But there are still problems. Permanent magnets aren’t mechanically strong, so the magnets inserted into the rotor make the rotor vulnerable to failure when it spins fast. In addition, a complex, expensive monitoring and control system is needed to keep the rotor just the right distance from the stator—close enough to be kept from dropping but not so close as to be grabbed tight.

Combining existing technologies

To Mohammad Imani-Nejad PhD ’13, Trumper’s graduate student and now a postdoctoral associate in the MIT Laboratory for Manufacturing and Productivity, the solution was to get rid of the permanent magnets as well as the bearings. Instead of using permanent magnets, he would suspend and drive the rotor using a phenomenon called hysteresis. “Imagine that there’s a memory in the material,” explains

Imani-Nejad. “If it’s in one state and then it’s switched, it takes a while to adjust to the new state.” If an external magnetic field is applied to, say, iron, then when the field is removed, the iron remains magnetized—until it’s exposed to a larger magnetic field in the opposite direction.

In a conventional motor, the hysteresis effect creates an energy loss, so engineers work hard to minimize it. In a hysteresis motor, however, it’s a useful mechanism. With careful controls, that lag in switching can cause the rotor—with its residual magnetization—to try to “catch up” with the present magnetic field of the stator; the rotor therefore turns with constant force, even when it’s first starting up. “Typically people try to avoid hysteresis,” says Imani-Nejad. “But here we welcome it. We want it to be larger.”

While self-bearing motors are relatively new, hysteresis motors have a long history, with early designs proposed about 100 years ago. But Imani-Nejad believes he’s the first to combine the two concepts. To support his novel idea, he first formulated new theoretical models of the forces involved and the control algorithms required. Guided by those calculations, he then designed, built, and tested three versions of his motor. While they differ in size and configuration, all share one critical feature: a smooth, solid rotor that contains no permanent magnets, joints, bolts, or laminations. It can be made of hard, high-strength steel in which the hysteresis effect is strong, and it can be shaped like a disk, an elongated cylinder, or any rotationally symmetric object—all well-suited to high-speed operation.

Novel designs

The photo to the right shows the first setup they built. It consists of a rotor sandwiched between two stators, top and bottom. Four sensors entering from the top monitor the position of the rotor, including any tilt and tip. Power amplifiers and other controllers respond by adjusting the current in the coils to keep the rotor suspended, stable, and spinning.

The sandwich approach brings several advantages. During high-speed operation, a strong centrifugal force will cause the rotor to expand—by as much as a few millimeters. In most motors, the rotor spins inside the stator—a sort of tube within a tube. When the rotor expands, the gap between the stator and rotor changes significantly, and the performance of the motor deteriorates. In contrast, the MIT design rotates a flat steel disk. Steel is generally viewed as strong and solid, but the design calls for the outside of the rotor to move at 500 meters per second. “In this domain—under this stress—it’s like it’s made of rubber,” says Trumper. So it responds to centrifugal forces and stretches—like pizza dough does when it’s spun. But because the rotor gets wider rather than taller, the distances to the stators above it and below it remain approximately constant.

A second benefit of the sandwich configuration is the potential for higher power. In demonstrations, the researchers showed that they could both levitate and rotate the rotor with a single stator above it. But with just one stator, there’s a limit to how much current they can pass through the coil before the rotor is yanked up against the surface of the stator. The lower stator enables them to create forces that pull the rotor down, away from top stator. By carefully

Hysteresis self-bearing motor

Photo: Mohammad Imani-Nejad PhD '13

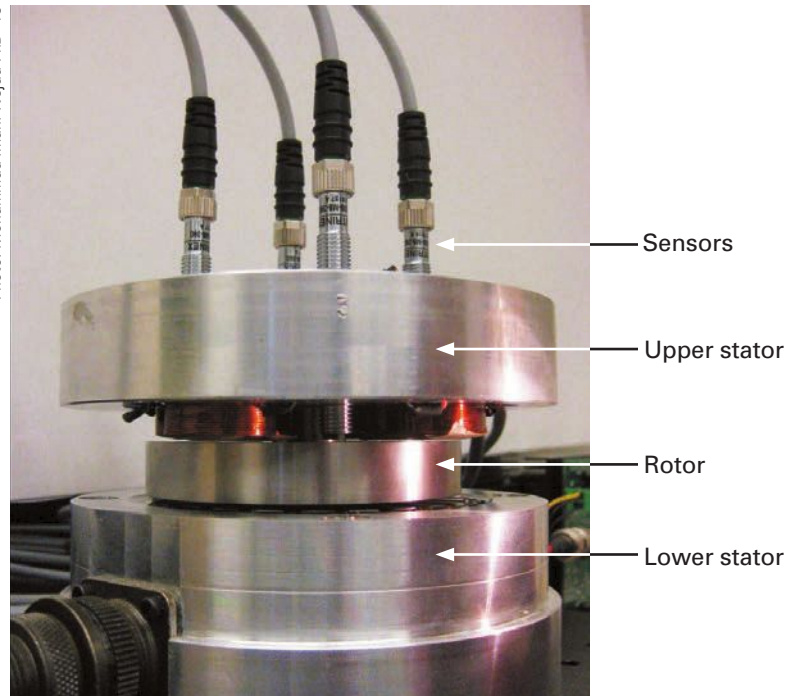

This photo shows the MIT researchers’ first motor designed to run at high speeds, free of both bearings and permanent magnets. The rotor at the center is solid, high-strength steel, with no joints or magnets to weaken it. Rather than resting on bearings, it is levitated by the stator above it. Electricity running through coils of wire on that stator produces magnetic fields that magnetize the steel of the rotor—an effect that can be manipulated to keep the rotor suspended, stable, and spinning. The unusual “sandwich” arrangement permits the researchers to keep the rotor at a constant distance from the stators above and below, even when currents are high and when centrifugal forces cause the rapidly spinning rotor to stretch.

balancing the upward and downward forces, they can further increase the current and thereby increase the torque—the force with which the rotor turns—to get more acceleration and more power out.

Windings and stators

With any motor, a major challenge is designing the coils and the currents they carry to create the magnetic fields needed to control the rotor. Methods of making coils for motors with permanent magnets are well understood, but Trumper and Imani-Nejad needed to depend on hysteresis—a far greater

challenge. Guided by his theoretical analyses, Imani-Nejad designed three sets of coils that turn the rotor plus another set that levitates it. His “multiple winding hysteresis motor” performs well. Over time, movement of the rotor stabilizes in some directions, but in others it must be actively controlled by measuring its position some 10,000 times a second and then changing the currents in the coils to control that position. “And it’s all done without contact, by the magnetic fields,” stresses Trumper.

In another of his hysteresis motors, Imani-Nejad redesigned the upper

Segmented stator

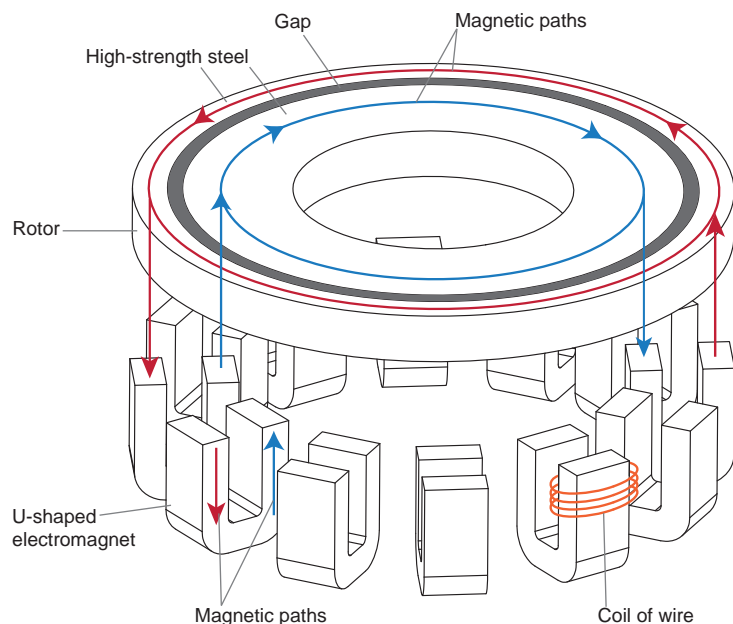

Photo: Stuart Darsch

In the novel design shown in the diagram and photo above, the stator is divided into a series of U-shaped electromagnets, or “cores.” A single coil of wire is wrapped around each one, replacing the usual complicated arrangement of overlapping coils. Instead of having to travel from one side of the stator to the other, the magnetic pathway is now confined to each core—a far shorter distance, which means reduced energy losses and increased motor efficiency. The coils are easily wound and require little space, so the segmented stator should be easier and less expensive to manufacture and assemble than conventional stators are.

stator itself. He divided it into 12 U-shaped electromagnets, or “cores,” as shown in the diagram and photo above. He then wrapped a single coil around each core, thereby replacing the complicated collection of overlapping coils. In this design, the magnetic pathway in the stator is shorter. Instead of having to travel from one side of the stator to the other, the pathway just runs up and down each of the U shapes. Energy losses are reduced, and motor efficiency is increased. In addition, the coils are easily wound and take up little space, so the segmented stator should be less expensive to manufacture than conventional stators are.

Focus on flywheels

When it comes to flywheels, the best design has a rotor that spins fast and is very tall—a long cylinder with lots of inertia. Imani-Nejad’s design for such a machine appears on the opposite page. It retains the sandwich arrangement with stators above and below the rotor, which is a tall cylinder made in part of a hysteresis material. Because of its shape, this rotor does not tend to tip or tilt but is unstable in just one direction—up and down. To support it, Imani-Nejad added pairs of permanent magnets at the top and the bottom. In both locations, one magnet is on the stator, the other at the end of the rotor.

The forces created by those magnets compensate for about 99% of the rotor’s weight, with the stators providing the remaining support. “We adjust the current to levitate it to make the system stable, but we only need to control for about 1% of the weight of the rotor,” says Imani-Nejad.

When they ran this new motor at 600 rpm, they found that the rotor stayed about half a millimeter away from the stators above and below, shifting by no more than 50 microns. Best of all, they could run it with a simple control system—without the dozen or more sensing and actuating elements generally required to run

Flywheel design

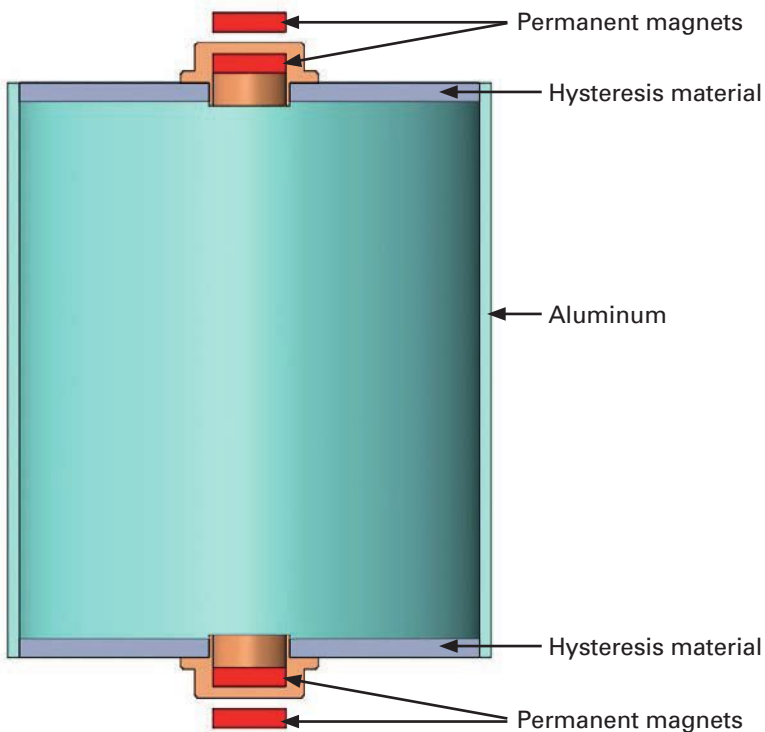

The tall, cylindrical rotor in this design is well-suited as a flywheel for storing energy. Because of its shape, the rotor here does not tend to tip or tilt, but it wants to drop because of its weight. The design therefore incorporates pairs of permanent magnets at the top and bottom that support about 99% of the rotor's weight. Stators above and below (not shown here) provide the remaining support. Because that task is relatively simple, keeping the rotor stable requires far fewer sensing and actuating elements than generally needed, making this system of significant practical interest.

self-bearing motors. "We showed theoretically and experimentally that with the right controller you can make this system stable by controlling movement along just one axis," says Imani-Nejad. "That makes it much less expensive and much less complicated—and very interesting for real-world applications."

Thus far, the fastest they've run any of their motors is at 10,000 rpm—appropriate for proof-of-concept demonstrations but not nearly the speeds needed to test for real applications. According to Trumper, it's also nowhere near the speed range that they could do. But they

can't yet safely test at high speeds.

"To go to those high speeds, you have to build a vacuum system and a proper containment vessel so if you do fail a rotor, it's not hazardous to the people in the lab," he says. "But the physics is such that these motors are capable of running at those speeds. We haven't proven it yet experimentally, but with the right equipment, we know we could do it."

• • •

By Nancy W. Stauffer, MITEI



Photo: Mohammad Imani-Nejad PhD '13

This research was supported by a seed grant from the MIT Energy Initiative and by ABB. Further information can be found in:

M. Imani-Nejad. *Self-Bearing Motor Design & Control*. PhD thesis, MIT Department of Mechanical Engineering. February 2013.

MIT and UC Berkeley launch energy efficiency research project

Energy efficiency promises to cut emissions, reduce dependence on foreign fuel, and mitigate climate change. That's why governments around the world are spending tens of billions of dollars to support energy efficiency regulations, technologies, and policies.

But are these programs realizing their potential? Researchers from the MIT Energy Initiative (MITEI) and the University of California (UC) at Berkeley's Haas School of Business are collaborating to find out.

The researchers' energy efficiency research project, dubbed "E2e," is a new interdisciplinary effort that aims to evaluate and improve energy efficiency policies and technologies. Its goal is to support and conduct rigorous and objective research, communicate the results, and give decision makers the real-world analysis they need to make smart choices.

The E2e Project is a joint initiative of the Energy Institute at Haas and MIT's Center for Energy and Environmental Policy Research (CEEPR), an affiliate of MITEI—two recognized leaders in energy research.

The project's name, E2e, captures its mission, the researchers say: to find the best way to go from using a large amount of energy ("E") to a small amount of energy ("e") by bringing together a range of experts—from engineers to economists—from MIT and UC Berkeley. This collaboration, the researchers say, uniquely positions the E2e Project to leverage cutting-edge scientific and economic insights on energy efficiency.

"Cutting energy has lots of potential to help us save money and fight climate change," says Michael Greenstone,



MIT's 3M Professor of Environmental Economics and a member of MITEI's Energy Council. "It's critical to find the local, national, and global policies with the biggest bang for the buck to use governments', industries', and consumers' money wisely while slowing climate change."

Greenstone is leading the project with Christopher Knittel, co-director of CEEPR, and Catherine Wolfram, associate professor and co-director of the Energy Institute at Haas.

"When deciding on the best energy measures to implement, decision makers should compare model predictions to actual consumer behaviors. That's where this project comes in," Wolfram says. "The E2e Project is focused on singling out the best products and approaches by using real experiments centered on real buying habits. It will provide valuable guidance to government and industry leaders, as well as consumers."

The group's motivations for studying energy efficiency are derived, in part, from the McKinsey Curve—a cost curve that shows that abating emissions actually pays for itself.

"Our goal is to better understand what the costs and benefits of energy-efficient investments are—where the low-hanging fruit is, as well as how high that fruit is up the tree," says Knittel, the William Barton Rogers

Professor of Energy Economics at the MIT Sloan School of Management. "The McKinsey Curve would suggest the fruit's already on the ground. If this is true, we want to figure out why no one is picking it up."

Former US Secretary of State George P. Shultz, a member of the E2e advisory board, says, "I like the saying 'A penny saved is a penny earned,' which rings true from the standpoint of energy. Energy that is used efficiently not only reduces costs but is also the cleanest energy around. The E2e Project will allow us to better understand which energy efficiency programs save the most pennies."

Shultz is a distinguished fellow at Stanford University's Hoover Institution, where he leads the Energy Policy Task Force. The board also includes MIT Institute Professor John Deutch, former undersecretary of the US Department of Energy (DOE); Cass Sunstein, a professor at Harvard Law School and President Obama's former director of regulatory affairs; Susan Tierney, managing principal at the Analysis Group and a former DOE official; and Dan Yates, CEO and founder of Opower.

The E2e Project seeks to answer questions such as: Are consumers and businesses bypassing profitable opportunities to reduce their energy consumption? What are the most effective ways to encourage individuals and businesses to invest in energy efficiency? Are current energy efficiency programs providing the most savings?

The project's first experiments are already under way. For example, the team is tracking consumers' vehicle purchasing decisions to discover whether better information about a car's fuel economy will influence

Angela Belcher wins \$500,000 Lemelson-MIT Prize

consumers to buy more fuel-efficient vehicles. If so, emphasizing the calculated fuel savings in the vehicle information presented to consumers may be productive.

Other initial projects include evaluating the Federal Weatherization Assistance Program and determining why households invest in energy efficiency and then estimating the returns on those investments.

The E2e Project was funded with a grant from the Alfred P. Sloan Foundation. For more information, go to e2e.mit.edu.

• • •

By Vicki Ekstrom, MITEI



Photo courtesy of Cambrios Technologies

Angela Belcher,
MIT's W.M. Keck Professor
of Energy

MIT Professor Angela Belcher, one of the world's leading nanotechnology experts, has been named the recipient of this year's \$500,000 Lemelson-MIT Prize, which honors an outstanding inventor dedicated to improving the world through technological invention. Belcher is the W.M. Keck Professor of Energy at MIT and a faculty member at the Koch Institute for Integrative Cancer Research. She has been a member of the MIT Energy Initiative's Energy Council since MITEI's founding in 2006.

Belcher, who heads up the Biomolecular Materials Group at MIT, draws her scientific inspiration from nature's ability to create materials—such as a snail's ability to grow its shell. In the lab, she designs novel hybrid organic-inorganic materials and uses them in a variety of applications, including solar cells, clean fuels, environmentally friendly batteries, and medical diagnostics.

Belcher's technology has given rise to two companies. In 2004, she co-founded Cambrios Technologies, which develops

electronic materials for transparent coatings used for touch screens, LCDs, and other devices. In 2007, Belcher co-founded Siluria Technologies, which converts lower-value methane gas into high-value liquid transportation fuel.

Belcher says she plans to allocate a portion of the award money to developing outreach programming focused on getting young children excited about science and bringing "cutting-edge and state-of-the-art technology into the classroom." Inspiring kids to take up science, technology, engineering, and mathematics (STEM) education is vital, she says. "The basis of solving many of the pressing global problems—such as energy, health, and food—lies in basic science and technological advances that the next generation can help develop," she says. "We need to show the youth that STEM is exciting and has a huge impact on society."

• • •

Excerpted from a press release by Rob Matheson, MIT News Office

New faculty strengthen, broaden MIT's energy expertise

Yogesh Surendranath

Assistant professor in the Department of Chemistry

Just a few years ago, Yogesh “Yogi” Surendranath was an MIT graduate student working on ways to use excess electricity from solar and wind systems to produce hydrogen for later power generation. This fall, he returned to campus as an assistant professor after spending two years as a Miller Postdoctoral Fellow at the University of California at Berkeley. Surendranath looks forward to continuing his research into finding more efficient and longer-lasting renewable energy storage techniques. He’s also excited to inspire young people at a formative age when they’re making decisions about what types of science to pursue. His first crop of mentees: undergraduate students taking advanced inorganic chemistry.

How is the energy landscape changing, and what should we do about it?

Today, we’re in the midst of a dramatic paradigm shift in how we think about energy in our societies. In the not-so-distant future, electricity from renewable energy sources such as wind and solar will—at certain times in the day—be cheaper than the fuel we dig out of the ground and burn. But this renewable energy can only be harnessed if we can develop efficient, cost-effective, energy-dense methods for its storage and later utilization during times of peak demand. We need to realize that the transition to a renewable energy economy will not occur overnight and there will be no single magical solution. Making the transition will require consistent, long-term funding and sustained work by both policy makers and researchers.

Photo: Karthish Manthiram



How does your research support that paradigm shift?

There are lots of technologies that can take electrical energy, store it in chemical bonds, and then discharge it when we need it. In all of them, a critical role is played by processes at interfaces, where electrons are doing the needed chemistry. My group works at the molecular level to understand those processes so we can design surfaces as well as catalysts to selectively and efficiently achieve the desired reactions. If we can develop systematic strategies for doing this, we can move to the next generation of technologies, for example, a lithium air battery with ten times greater energy density or an electrolyzer that can take carbon dioxide from waste streams and—using wind or solar energy—convert it to another fuel source.

How has your experience at MIT affected your perspective as a scientist?

The high level of motivation and optimism here really sets MIT apart from other institutions and makes it a very inspirational environment, especially for work in the energy space. The MIT Energy Initiative [MITEI] has created a culture where it is very clear that energy research is supported and has strong institutional backing—one of the assets that drew me to the Institute. As a researcher here, I’ve learned that it’s foolhardy to believe we can act in a vacuum without knowing the constraints of scale and cost faced by industry. Connecting researchers with global energy companies—as MITEI does—exposes us to these design constraints. That’s important because our role as scientists is not only to think of the most innovative solution but also the solution that is simplest, most cost-effective, most scalable, and most durable. That is a different sort of thinking than what academic scientists are used to. Being at MIT, both as a graduate student and now as a professor, has helped me realize that innovative technologies will remain an academic curiosity unless they are designed with a deep appreciation for the real-world challenges they target.

Noelle Selin

Assistant professor in the Engineering Systems Division and the Department of Earth, Atmospheric, and Planetary Sciences

Noelle Selin's professional interests have always centered on the intersection of policy and the environment. During her undergraduate training at Harvard University, she pursued an interdisciplinary major in environmental science and public policy. She also worked on toxic chemicals issues for the US Environmental Protection Agency and spent a year as a Fulbright fellow with the European Environment Agency. But to really make an impact, Selin felt she needed deeper knowledge. After earning her PhD in atmospheric chemistry from Harvard University, she found the perfect fit performing interdisciplinary research at MIT. From engaging with state and national air pollution regulators to briefing delegates during international negotiations, Selin constantly designs her research to be responsive to the needs of policy makers and strives to communicate her results effectively. She is currently part of the Stanford-affiliated Leopold Leadership Program for mid-career academics, where she is honing her skills in designing and communicating research related to the environment and sustainability.

You're currently working on a MITEI seed grant project. What are your goals in this research?

Recently, there have been a lot of air quality improvements that may have altered the background chemistry of the atmosphere. If we don't account for those changes when evaluating current

Photo: Patrick Gillooly, MIT



and future regulations, we may end up with regulations that are less effective than predicted. To help in such analyses, Susan Solomon of earth, atmospheric, and planetary sciences, John Reilly of the MIT Joint Program on the Science and Policy of Global Change, and I are creating a dynamic model that can quickly show which pollutants to reduce to get the biggest benefits. We're beginning our research by looking at the US, but the model could easily be applied to other regions, and we hope to use it to examine air quality in the context of climate policy.

What's been involved in making your model a useful tool for policy makers?

The real challenge for all modelers in this area is to represent the complexity of the atmosphere and to take uncertainties into account in a rigorous way, while also obtaining results that are simple and specific enough to help policy makers. We're designing the model to confront this tension without making it too complicated and time-

consuming to run. We're doing so by taking key elements from different complex models and deciding what's needed to approach the actual problem in the environment. Then we're piecing all the most useful information together into one model.

What methods do you use to teach your students how to make their research relevant to policy?

I encourage students to think critically about how to bring knowledge to action by engaging them in current policy discussions. For example, during last year's Independent Activities Period [at MIT], I took a group of students to the international mercury negotiations in Geneva, Switzerland. Each student was assigned a mercury-related topic and asked to blog about the latest developments in that area. This fall, my class is taking a virtual field trip via webcast to the climate negotiations [at the Conference of the Parties] in Warsaw, Poland, and the class assignments are blog posts where students give scientific assessments, issue summaries, and updates on the negotiations. My goal is to get students to think about what science is relevant to policy development and how to communicate it, so they can be engaged in the policy-making process.

View Selin's mercury blog at mercurypolicy.scripts.mit.edu/blog and her climate blog at esd110.mit.edu.

Alexie Kolpak

Assistant professor in the Department of Mechanical Engineering

As a postdoctoral associate at Yale, Alexie Kolpak was looking for something new. She started scanning the American Physical Society abstract book for interesting research, and MIT Professor Jeffrey Grossman's name kept popping up. Kolpak connected with Grossman and soon accepted a postdoctoral position in his group. Along with providing valuable research opportunities, Grossman taught Kolpak the fundamentals of running a research group—knowledge she has put to work since becoming an assistant professor at MIT last fall. With funding from a MITEI seed grant, Kolpak is now working on a process to make carbon capture and storage (CCS) more economically feasible. She's also looking at ways to make solar cells more efficient and to split water molecules to turn hydrogen into fuel.

What drove you toward this career path?

In high school, I had never thought about science until, ironically, I did an English paper on biotechnology. I thought it was so fascinating and wanted to dig deeper, but I still wasn't convinced it was for me. In college, I toyed with becoming an English major while also taking biochemistry classes. I found myself asking questions like, "Why does that happen? Why does this reaction occur? Why does this structure form the way that it does?" I was really eager to learn more about processes at the atomic scale. Once I got to MIT, I realized we could actually have a big impact on a lot of important technologies and societal issues if we could use

Photo: Jim Miller



the knowledge we were gaining at this scale to develop smart materials and put them to use in a realistic way. That has become an exciting driver for me.

How are you working to improve the CCS process?

I'm working on a technique that would chemically alter surfaces to make CO₂ react with the surface and produce a useful product. This could be used, for example, in cars. Exhaust could come through a converter that captures the CO₂ and changes it into methanol. Then the methanol would feed into another tank to use for fuel. On a larger scale, this same type of process could be used in power plants to help make CCS more economically feasible because the process would create usable products like cyclic carbonates, which are used in plastics and as solvents. Making CO₂ into something useful, rather than simply treating it as waste, would offset the cost of implementing the technology.

With your research based in chemistry, how did you end up in the mechanical engineering department?

That's one of the things I love about MIT. There aren't really lines between disciplines. People here understand that a very interdisciplinary approach is needed to solve these types of all-encompassing global challenges. My research is a perfect example. Usually, you wouldn't associate the work I'm doing with mechanical engineering. But it's becoming a lot more important to actually understand what's happening at the atomic scale. To give a clear example, though not from my own research, when you think of concrete, you think of it as a building material, but it produces 5% of CO₂ emissions. So people are looking at the chemistry of concrete to try to develop new ways to make it so that it doesn't produce that much pollution. So chemistry is directly linked to the more traditional mechanical engineering. By being part of the mechanical engineering department, I'm learning things I never would have thought about if I hadn't been in this department. It's opening up lots of new directions.

Christopher Warshaw

Assistant professor in the Department of Political Science

When Christopher Warshaw graduated from Williams College with an economics degree, he expected to take a couple years off before continuing his education in economics. But after doing cost-benefit analyses in an environmental consulting firm, he realized that smart economics wasn't driving policy; politics was driving policy. To learn politics from the ground up, he went to work on campaigns for two years before deciding to pursue a PhD in political science. Now, Warshaw is analyzing the political forces behind policy development and the role public opinion plays.

Why did you decide to come to MIT, and how do you hope to make a difference here?

The collaborative work happening at MITEI and throughout campus that brings together scientists and engineers is really exciting. Working with engineers, and in this engineering culture, influences our work to the extent that the political science department here really focuses on applied research much more than at many other top-notch programs. Applying my research to policy is something that's really important to me.

The engineering mindset also influences the students. The students are really motivated to find solutions to real problems. At the same time, I think it's important for students to be exposed to a wide variety of perspectives because it's been my experience working in politics, nonprofits, and government that smart people can rise really fast. The students here are

Photo: Stuart Darsch, courtesy of MIT Department of Political Science



brilliant; we just need to give them the right training and expose them to the complexities of these issues. And if we do, I believe they can really make a difference very quickly in the world.

What drove you to this research?

Climate change has always been one of my main drivers. Part of confronting that challenge means thinking about how we can use cleaner sources of energy. Underlying that is an economic challenge: How can we keep power affordable and allow our economy to keep going forward? But when I was at the consulting firm, I realized there was a lot more to confronting the climate challenge than determining the smart economic choices. To contribute to positive changes in the world, I needed to understand more about how the world works. That led me to political science research. While most of my work addresses broad issues, the methodological tools and new statistical techniques can be applied to specific energy and environmental issues.

What are the research questions you're looking to solve, and what have you found out so far?

My main research questions are: What is it that causes us to end up with the types of policies that we have? How well do those policies represent public opinion? And, if people are to be effective advocates and effective citizens, how can they get involved and make a difference? In applying these questions at a national level, I've found that it's hard to get legislators to vote against their partisan priorities. In fact, it takes vast shifts in public opinion to change legislators' roll call votes. Applying this research to the energy sphere is a challenge because there isn't enough survey data to actually know what people want, especially at a local level. For example, you'd expect that in Wyoming people are pro coal, but we don't actually know because there are no surveys of public opinion on environment and energy at the local level. So in the future, I'd like to run surveys to measure public opinion on specific energy policies. This will enable me to look at the relationship between public support for specific policies and the policies that states actually implement.

• • •

By Vicki Ekstrom, MITEI

Energy Fellows, 2013–2014

The Society of Energy Fellows at MIT welcomed 38 new members in fall 2013. The Energy Fellows network now totals nearly 300 graduate students and postdoctoral fellows and spans 20 MIT departments and divisions and all five MIT schools. Fellows now include incoming graduate students and graduate student researchers, teaching fellows, and postdoctoral associates. This year's fellowships are made possible through the generous support of 15 MITEI member companies.



Photo: Justin Knight

Bosch

Michael Pretko
Physics

BP

Ricardo Charles
Mechanical Engineering

Dehann Fourie
Electrical Engineering and
Computer Science

Abigail Halim
Materials Science
and Engineering

Michelle Hindman
Chemical Engineering

Jayson Lynch
Electrical Engineering and
Computer Science

Priya Moni
Materials Science and Engineering

Danwei Zhang
Engineering Systems Division

Chevron

Shannon Jegg
Chemical Engineering

Cummins

Alex Breckel
Engineering Systems Division

EDF

Sandra Jenkins
Engineering Systems Division

Eni

Po-Yen Chen
Chemical Engineering

Noemie-Manuelle Dorval Courchesne
Chemical Engineering

Francesca Freyria, PhD

Chemistry

Donald MacKenzie
Engineering Systems Division

Jill Macko
Materials Science and Engineering

Justin Nelson
Chemical Engineering

Jee Soo Yoo
Materials Science and Engineering

Nora Xu
Engineering Systems Division

Seonkyoo Yoon
Civil and Environmental Engineering

Ferrovial

Bo Jiang
Mechanical Engineering

Ella Kim
Urban Studies and Planning

ICF

Michael Davidson
Engineering Systems Division

Lockheed Martin

Daniel (Joowon) Kwak
Nuclear Science and Engineering

Saudi Aramco

Jeffrey Kowalski
Chemical Engineering

Anna Wuttig
Chemistry

Schlumberger

Mirna Slim
Earth, Atmospheric, and
Planetary Sciences

Shell

Griffin Clausen
Biological Engineering

Priyank Kumar
Materials Science and Engineering

Jing Liu
Earth, Atmospheric, and
Planetary Sciences

S. Ahmad Zamanian
Electrical Engineering
and Computer Science

Nan Zhao
Media Arts and Sciences

Total

Manuel Florez Torres
Earth, Atmospheric, and
Planetary Sciences

Jarrod Milshtein
Materials Science and Engineering

United Technologies Corporation

Cecile Casses
Aeronautics and Astronautics

Nicole Labruto
Science, Technology, and Society

Weatherford

Jared Atkinson
Earth, Atmospheric, and
Planetary Sciences

Charith Mendis
Electrical Engineering and
Computer Science

Fellows as of November 1, 2013

Eni and MIT Energy Initiative announce launch of Energy Society

Eni and the MIT Energy Initiative (MITEI) announced the launch of the Eni-MIT Energy Society during the “Italianissimo!” event held at the Boston Public Library on June 7, 2013. In Eni’s vision, this society will become the MIT chapter of a new Eni Energy Society, which will bring together Eni’s sponsored students from all over the world.

Eni is a Founding Member of MITEI and its largest energy research sponsor. As part of its commitment, Eni supports about 10 Eni-MIT Energy Fellows per year on energy and environmental projects. Sixty Eni-MIT Energy Fellows and more than 100 graduate students have been supported by Eni since 2008, and they are now the inaugural members of the Energy Society. The society establishes a forum for long-term relationships between Eni and students, past and present, who have benefited from Eni’s support and who have contributed

to a diverse array of energy research projects and innovations.

For Eni CEO Paolo Scaroni, “the creation of the Eni-MIT Energy Society is an example of how energy, culture, and relationships can come together. It also provides a robust new opportunity to unite Eni’s skills with MIT’s excellence in scientific and technological research.”

Of the society, MITEI Director Robert Armstrong said, “Eni’s support for MIT energy students has been an important contribution to bringing the best and brightest students to address the world’s energy challenges. The Energy Society brings a new dimension to our partnership by strengthening the network of students connected to Eni and its vital energy research agenda.”

Earlier this year, Eni and MIT renewed their energy partnership. MIT President L. Rafael Reif and Scaroni celebrated

the successes of the first five years and established the path forward for this energy research collaboration.

Eni’s research projects at MIT span the entire energy spectrum, from solar energy to traditional hydrocarbons to methane hydrates. Advanced solar research has been a significant focus of the Eni-MITEI partnership. The Eni-MIT Solar Frontiers Center (SFC), established in May 2010, serves as a central hub for this research drive, and many Eni-MIT Energy Fellows work on these projects. The SFC is home to many notable innovations, including the development of solar cells printed on paper. Flexible photovoltaics, biologically inspired technology, and solar concentrators will also be explored in the coming years.

• • •

By Vicki Ekstrom, MITEI

Photo: Justin Knight



Front row: Robert Armstrong, MITEI director (far left), Nicola De Blasio, MIT visiting scholar and Eni representative (far right), and Amanda Graham, director of MITEI’s Education Office (second from right) pose with Eni-supported students, past and present.

MIT undergraduates plunge into summer energy research

During summer 2013, MIT Energy Initiative members and donors supported the work of 43 undergraduate students on energy-related Undergraduate Research Opportunities Program (UROP) projects spanning a wide range of topics. Funders include Founding Member BP; Sustaining Members Chevron, Lockheed Martin, Schlumberger, and United Technologies Corporation; the Tata Center for Technology and Design; and individual Affiliate members with a particular interest in supporting undergraduate research.

Right: Chester Chambers '15 of chemical engineering adjusts the flow through his electro dialysis setup, a system designed to increase the concentration of salt in a brine solution to facilitate the salt/water separation process. This approach could lead to more energy efficient, less costly methods of desalinating seawater and of disposing of saline waste streams in the oil and gas industry.



Photos: Justin Knight



Left: Viveka Mishra '14 of mechanical engineering (left) and Carlos Greaves '13 of electrical engineering and computer science demonstrate their Portable Light device in which photovoltaics embedded in flexible textiles can power an onboard lamp or charge USB-compatible cell phones. Such textile-based energy-harvesting devices can deliver power to regions of the developing world where people have no access to a power grid.

Arriving MIT undergrads immerse themselves in energy

Twenty-four entering MIT undergraduate students participated in the MIT Energy Initiative's Freshman Pre-Orientation Program—Discover Energy: Learn, Think, Apply (DELTA) in August 2013. From discussing sustainability initiatives with Cambridge Mayor Henrietta Davis to constructing and racing their own mini solar cars, incoming DELTA students experienced a wide array of energy-focused activities.



DELTA students Ostin Zarse (left) and Alexandra Delmore adjust the wheels of their model solar car to ensure its stability at high speeds over rough terrain.



One highlight of the program was working in small groups to build prototype solar cars. Here, one team discusses possible approaches to designing a solar car using the supplied materials, which are spread out on the floor.



Wesley Cox tracks his team's solar car as it travels along the bike path near MIT's Stratton Student Center. In a series of competitions, each car was judged based on its stability and speed as well as the creativity of its design. For the final stability challenge, students attempted to have their cars survive driving down the numerous steps at MIT's main entrance at 77 Massachusetts Avenue.



During a private tour of the MIT cogeneration power plant, Peter Cooper (right), MIT's manager of sustainability engineering and utility planning, explains the processes involved in simultaneously generating heat and electricity in one station. The DELTA students also learned about the flow of energy throughout the MIT campus, from generation and distribution to end-use consumption, and about MIT's efforts to make every step as efficient as possible.

Photos: Justin Knight

DUSP students develop energy efficiency plan for Cambridge

Graduate students taking a spring 2013 practicum in MIT's Department of Urban Studies and Planning (DUSP) urged utilities and government leaders to consider a range of innovative approaches to the thorny problem of how to spur energy efficiency upgrades in multifamily housing.

Working with and for real clients—NSTAR Electric and Gas and the City of Cambridge—the students developed a multifaceted pilot program to address the 84% of Cambridge households that live in multifamily dwellings. This population has proved hard to reach with the Mass Save residential energy efficiency program, funded by several Massachusetts utilities including NSTAR, which has so far been most successful at encouraging energy efficiency upgrades in single-family homes.

"NSTAR and the City of Cambridge wanted our students to explore new approaches to encourage multifamily building owners to more frequently pursue efficiency upgrades, especially in the 2-20-unit buildings typical of Cambridge and many older communities," says Harvey Michaels, director of DUSP's Energy Efficiency Strategy Project and instructor for the class: 11.S948 Community Energy Innovations. "In this type of building, there is a split incentive between landlord and tenants," he says, noting that while landlords bear the cost of building upgrades, they don't often see the rewards of lowered utility bills because those are typically paid by tenants.

"We are continually looking to better understand and address the structural barriers to energy efficiency, and courses such as this bring sustained attention to those issues," says Tilak Subrahmanian, NSTAR's vice president for energy efficiency. "Working with

MIT students on energy efficiency strategy provides us with rigorous debate that stretches our thinking, and we are certainly better off for it."

Cambridge Mayor Henrietta Davis says that addressing the energy woes of the city's multifamily housing stock is an important step if the city is to meet the challenges presented by climate change. "Eighty percent of our energy use is in buildings," she says. "Most of that is commercial buildings, but next, within the residential sector, it's multifamilies."

To familiarize students with all of the project's stakeholders, the class began with a series of presentations by government and industry experts, including state and Cambridge officials, NSTAR representatives, and contractors who perform energy upgrades. Students also interviewed Cambridge residents, property managers, and multifamily housing advocates to ascertain the needs of the community.

"I learned a lot about the institutional framework that energy efficiency programs work in, a lot of the stakeholders involved, and what their motivators are," says Ryan Cook, a DUSP graduate student in the course.

"That was what made this practicum difficult," says DUSP graduate student Alex Marks. "We had to really think very broadly about our message and how that would work for a variety of different audiences."

MIT Energy Innovations Symposium

On April 26, the students presented their initial proposals at the MIT Energy Innovations Symposium. The half-day event was attended by about 60 people, including Davis; Bradford Swing,

Boston's director of energy policy and programs; and representatives from NSTAR, the US Department of Energy, and several efficiency service providers. "This is just one example of how MIT has been leading on walking the talk and helping others to do the same," Davis says.

The student presentations were followed by roundtable discussions focused on the proposals. "We got a lot of movers and shakers in the room together, and we led a discussion of what this multifamily program might look like," Cook says. "It was great to have these practitioners taking us seriously."

The students described how NSTAR and Cambridge could join forces in a new program specifically targeted at multifamily housing. Key features of the program include:

- **Streamlined energy audits.** The students found that taking advantage of the free audits via the current Mass Save program was an onerous process, which served as an added impediment to participation by landlords. Students therefore proposed a streamlined process that would begin with a "no-touch audit" using data from a wide variety of public sources (such as building permit records) to target buildings most likely to benefit from upgrades, followed by an on-site assessment and project quote.
- **One-stop shopping.** Since there is currently no single point of contact for a customer interested in participating in NSTAR's efficiency program, students proposed that the city appoint a program implementer to guide customers through the process.

Photo: Harvey Michaels, MIT



At a half-day symposium on April 26, 2013, MIT graduate students presented an innovative, multifaceted pilot program specially designed to spur energy efficiency upgrades in multifamily housing in Cambridge, Massachusetts. About 60 people attended the event and provided feedback on the proposed program, which the students had developed in their spring practicum in urban studies and planning, working with representatives from NSTAR Electric and Gas and the City of Cambridge.

- **No money down.** Students determined that for the utility to capture the multifamily market, it would have to finance efficiency improvements. Landlords could upgrade apartments with no upfront cost and pay back the principal over time via their energy bills, with any increase offset by energy savings. This part of the plan also allows landlords to pass some costs onto their tenants after 18 months.
- **Community-based social marketing.** Since neighbors often live in similar types of buildings and have similar energy efficiency problems, students proposed using social marketing to spread the word about the program, highlighting the savings gained through successful upgrades. They also suggested that the City of Cambridge take the lead in promoting the program to residents, taking advantage of its trusted role in many communities.

“We were very focused on social marketing—working through existing community groups—to get people to think about audits because they’re likely to benefit,” says Lawrence E. Susskind, MIT’s Ford Professor of Urban and Environmental Planning and a co-instructor for the class. “People roll their eyes if you say [improving

efficiency] has to be done neighborhood by neighborhood, but that’s really the scale at which change is happening.”

Improving student housing

Students also addressed two key concerns for the tenants of Cambridge’s multifamily housing—household comfort and environmental impact. “Students are experts at living as tenants in these 100-year-old buildings,” Michaels says. “In many of these buildings, tenants can’t control the heat. But fixing the comfort problem isn’t yet addressed by the Mass Save energy efficiency program.”

The value of comfort is obvious to tenants, however, so the MIT students suggested that the pilot program offer a number of energy-saving technologies that would also enhance comfort, such as steam radiator controls and Internet-enabled thermostats. Since Cambridge residents are very eco-conscious, students also proposed providing landlords, tenants, and prospective tenants with more information about the energy efficiency of buildings as well as about how home energy savings can reduce their carbon footprints.

“Our heart was in trying to make the off-campus experience for students

better,” Marks says. “MIT students come here and want to learn about how to make the world a better place, yet they’re in highly energy-inefficient homes.”

Following the April symposium, students took the feedback from stakeholders and refined their proposal, submitting a final report in May. “This was a very cool project because it confronted a lot of the institutional barriers to energy efficiency,” Cook says.

NSTAR and Cambridge are continuing to evaluate the plan. Other supporters of the MIT Energy Efficiency Strategy Project, which funded this practicum, include the US Department of Energy and its National Renewable Energy Lab, and the Edison Foundation Institute for Electric Efficiency.

• • •

*By Kathryn M. O’Neill,
MITEI correspondent*

New position aims to strengthen MIT's sustainability

Julie Newman, MIT's first director of sustainability, brings to her new post a portfolio as one of the nation's most experienced leaders on sustainability in higher education.

Newman, who assumed her role in mid-August 2013, came to MIT from a similar position at Yale University, where she led a sustainability initiative for the last nine years. MIT Executive Vice President and Treasurer Israel Ruiz initiated the creation of the new post—and simultaneously created an Office of Sustainability to serve as a catalyst for advancing sustainable approaches and practices across campus and beyond.

"Julie brings an unparalleled level of energy and enthusiasm to the work of integrating sustainable processes into all aspects of the Institute," Ruiz says. "Her presence on campus brings us one step closer to realizing our vision of the campus as a living laboratory where we test new ideas. Julie will be key to advancing MIT's work with both the City of Cambridge and the City of Boston."

Starting in 1997, Newman spent seven years establishing an office of sustainability at the University of New Hampshire—"one of the first offices of sustainability in the country," she says. After receiving her doctorate in natural resources and environmental studies from UNH in 2004, she moved to Yale as founding director of its Office of Sustainability.

Newman is "excited about...the opportunity to work as a catalyst to ensure the integration of sustainability principles across all the operational units of the Institute." She plans to examine "what the underlying goals are, ranging from capital construction to small-project

renovations, energy systems, transportation systems, operations and maintenance, waste management, recycling, water management, procurement, and land management." Her analysis will also examine novel opportunities for financing, organizing, and planning such projects.

Newman aims to position MIT's campus "as a living and learning laboratory for sustainability. When successful, our campus sustainability work will make direct and meaningful contributions to the core teaching and research mission of the Institute." The opportunities, she says, "may range from testing new technologies currently being developed in labs on campus to studying the organizational behavior that enables a sustainable campus."

Newman will help build upon MIT's past sustainability accomplishments. For more than 10 years, MIT has taken steps to reduce its energy and environmental impact while actively contributing to local, regional, and global initiatives. For example, Building E62 at the Sloan School of Management—opened in 2010—consumes 45% less energy than some comparable buildings; and more than 90% of MIT's existing buildings have been retrofitted for energy efficiency.

"We're delighted to have Julie join MIT, bringing her leadership and expertise to our campus sustainability efforts," says Robert Armstrong, director of the MIT Energy Initiative (MITEI). "She and the new sustainability office will enhance our already strong collaboration with the Office of the Executive Vice President and Treasurer and the Department of Facilities in education, faculty engagement, and student projects both inside and outside the classroom."



Photo: Dominick Reuter

Julie Newman, MIT's first director of sustainability, is leading the Institute's programs in sustainable energy, water, and other resources.

John Sterman, the Jay W. Forrester Professor of Management at MIT Sloan and a member of MIT's Campus Energy Task Force since its establishment by MITEI in 2007, says that the creation of this new position "will help us accelerate the progress we've been making to become more efficient and to promote sustainability more broadly." He applauds the selection of Newman, calling her "knowledgeable, experienced, and energetic."

Joining Newman in the Office of Sustainability are deputy director Steven Lanou, who previously led sustainability programs in MIT's Environment, Health, and Safety Headquarters Office, and sustainability projects coordinator Susy Jones.



Adapted from an article by David L. Chandler, MIT News Office

MIT signs compact for sustainable future with City of Cambridge and Harvard

In what is considered to be the first agreement of its kind, MIT, Harvard University, and the City of Cambridge have entered into a compact to work collaboratively to address issues related to climate change on a local basis.

The Community Compact for a Sustainable Future lays out a framework for the signatories—and other organizations that choose to join—to work in a more coordinated and robust fashion to tackle local sustainability challenges. The compact aims to leverage the different organizations' core skills and competencies in research, best practices, and governance to generate new solutions in the areas of waste reduction, energy efficiency, climate mitigation and adaptation, water management, renewable energy, and green technology incubation.

MIT President L. Rafael Reif joined Cambridge Mayor Henrietta Davis, City Manager Bob Healy, Harvard President

Drew Faust, and Akamai CEO Tom Leighton at the signing, which was the opening event on May 6, 2013, of the Symposium on Sustainable Urban Design, hosted by Associate Professor of Architecture Christoph Reinhart and MIT's Sustainable Design Lab.

In his remarks, Reif observed that MIT and the City of Cambridge are already collaborating on many sustainability-focused projects, including the Hubway bike-sharing system and mapping of local solar-power potential. "By working together—through this compact—we will greatly increase our ability to understand the true nature of the challenge. And we will improve our ability to make the progress that our shared future depends on."

Going forward, organizers hope the compact attracts new signatories from the corporate and nonprofit sectors in Cambridge. A steering committee will oversee the collaborative effort by

identifying priorities, coordinating work, collecting data, evaluating progress, and creating a forum for annual reporting. Akamai is the first business to join the compact. Reif remarked that Akamai's innovative and entrepreneurial culture revolutionized the Internet, and that those same qualities will be a tremendous asset to the collaboration.

Davis, who spearheaded the initiative, said: "Cambridge is uniquely positioned to serve as a leader in this response; we have unmatched intellectual capital and a culture of innovation and commitment to the environment. I am thrilled to partner with Harvard and MIT."

To read the compact, go to web.mit.edu/newsoffice/images/documents/cambridge-compact.pdf.

• • •

MIT News Office



Seated at the table, from left: Harvard President Drew Faust, MIT President L. Rafael Reif, Cambridge Mayor Henrietta Davis, and Cambridge City Manager Bob Healy sign the Community Compact for a Sustainable Future.

Photo: Dominick Reuter

Event highlights need for women in clean energy

Women represent about a quarter of the workforce in science, technology, engineering, and math, or STEM, fields. These fields are the backbone of energy innovation, and since similar gender ratios are evident in clean energy finance and policy, closing the gender gap and increasing women's participation and leadership in this sphere is the goal of the US Clean Energy Education and Empowerment (C3E) program.

A partnership between the US Department of Energy (DOE) and the MIT Energy Initiative (MITEI), the US program is part of the international C3E Initiative within the 23-government Clean Energy Ministerial (cleanenergyministerial.org) framework. The program held its second annual symposium, hosted by MIT, on September 19 and 20, 2013, at the MIT Media Lab.

Guler Sabanci, the chair and managing director of Sabanci Holding—Turkey's leading industrial and financial conglomerate—kicked off the day-and-a-half event. Sabanci cited figures indicating that women make up 80% of humanities majors but only 11% of electrical engineering majors and 20% of physics majors.

"We definitely need more capable, determined, innovative women to work with us," Sabanci said, noting that both clean energy and women have been underutilized. "We all believe the future belongs to both of them."

The key, Sabanci said, is not just to bring more women into the clean energy workplace but to realize that women bring an important perspective as "change agents" in their communities—a theme reflected throughout the event.



Photos: Justin Knight

On September 19 and 20, 2013, the US Clean Energy Education and Empowerment (C3E) program held its second annual Women in Clean Energy Symposium, hosted by MIT at the MIT Media Lab. More than 200 invited leaders from across the energy sector attended the event, with many more participating via webcast.

Recognizing leadership, building a community

One of the main goals of the C3E program is to build a community of professionals dedicated to recognizing and advancing the careers of women in clean energy. To that end, C3E highlights role models for young women to follow, specifically through the presentation of a Lifetime Achievement Award and six awards for mid-career women.

The mid-career award winners are selected each year from nationwide nominations and chosen by the C3E Ambassadors—a group of about 30 distinguished leaders in energy committed to championing the program's success by serving as spokespeople and mentors. Along with the recognition, each winner receives a \$10,000 award from MITEI for her clean energy work.

This year's award winners in C3E's six categories are:

Innovation and Technology Development

Milo Werner, senior manager, New Product Introduction, Tesla Motors

Entrepreneurship and Innovative Business Models

Erica Mackie, co-founder and CEO, GRID Alternatives

Corporate Implementation

Kirstin Gunderson, senior manager, renewable energy, Walmart

Policy and Advocacy

Rebecca Stanfield, senior energy advocate, deputy director for policy, Midwest Program (Chicago), Natural Resources Defense Council

Education and Mentorship

Kristen Graf, executive director, Women of Wind Energy

Advancements for the Developing World

Katherine Lucey, chief executive officer, Solar Sister



Kicking off the event, Guler Sabanci, chair and managing director of Sabanci Holding, notes the need to bring more women into the clean energy workplace and stresses the important perspective they bring as “change agents” in their communities.

Additionally, the C3E Ambassadors presented the Lifetime Achievement Award to Maxine Savitz, former general manager at Honeywell, Inc., and current vice president of the National Academy of Engineering. Savitz’s four decades of service span government, industry, and academia. During her career at Honeywell, Savitz oversaw the company’s technology partnerships program and supervised the development and

manufacturing of innovative materials for the aerospace, transportation, and industrial sectors. Previously, Savitz worked at DOE and its predecessor agencies and served as the deputy assistant secretary for conservation.

C3E Ambassadors Marilyn Brown of the Georgia Institute of Technology, Sue Tierney of the Analysis Group, and Mary Anne Sullivan of Hogan Lovells



Maxine Savitz, vice president of the National Academy of Engineering and a former general manager with Honeywell (second from right), receives the Lifetime Achievement Award for her long history of clean energy leadership. Presenting the award are C3E Ambassadors (from left) Marilyn Brown, Mary Anne Sullivan, and Sue Tierney.

US LLP presented Savitz with the award, saying, “She’s done it all.”

The ambassadors read a congratulatory statement from US Energy Secretary Ernest Moniz in which he acknowledged Savitz’s “outstanding public service advancing energy efficiency and energy technology innovation for nearly forty years.”

Moniz, who served with Savitz on the President’s Council of Advisors on Science and Technology (PCAST), mentioned that a PCAST task force they served on together had recommended approaches to accelerating energy technology innovation. “This work led to President Obama’s directive in his Climate Action Plan for a Quadrennial Energy Review, a major undertaking to weave together the many threads of energy policy development,” Moniz’s statement said. “This is just one example of how Maxine has been a considerable force for clean energy—and a wonderful colleague, too.”

In her acceptance speech, Savitz named the factors that led to her success. In addition to having a strong education, she said surrounding yourself with good people is really important. “Networking with people. Collaborating with people. Things don’t happen when you don’t have good people working with you,” Savitz said. She also said having a passion for your work and the persistence to see it through is vital—as is having fun.

In addition to highlighting role models such as Savitz and the other award winners, the symposium built on its goal of fostering a community of women in clean energy through “speed networking,” an interactive climate change negotiation simulation, and small group dinners hosted by the



Priyanka Chatterjee, an MIT junior majoring in mechanical and ocean engineering, describes Solar “Float”voltaics during her undergraduate lightning presentation session.

C3E Ambassadors. The conference was also webcast, and moderators took questions from Twitter to engage a larger audience.

To further bring young women into the program, the symposium included 15 MIT undergraduate students who gave “lightning presentations” on their research. MIT also ran a nationwide graduate student poster competition on the theme of climate change mitigation and adaptation. The 12 finalists of the competition displayed their posters at the event. Symposium participants voted by ballot for the best poster and chose Carolyn Jenkins of MIT’s Department of Architecture as the winner for her poster on the East Boston Buffer as a transferable urban framework for adapting to sea level rise. Jenkins received a \$5,000 award for her poster.

Confronting 21st century challenges: Women and innovation

While building a community, the symposium also served to provide women—and men—in clean energy with a range of perspectives and analysis on the challenges and opportunities before them.

One challenge—for both startups and corporations—is how to bring innovative clean energy technologies into the marketplace. MITEI Director Robert Armstrong said the way to do that successfully is to “link research to development to deployment, and that means working across government, universities, industry, and foundations.” Speakers from each of those spheres offered their insights during the symposium’s panel sessions.

Karen Wayland from DOE’s Office of Energy Policy and Systems Analysis spoke about the actions that the US government is taking to encourage

energy innovation and confront perhaps the greatest challenge of our time: climate change.

“[Climate change] is real, it’s happening, and it’s impacting our electricity system,” Wayland said. “And our energy system produces 85% of domestic greenhouse gases....We can’t do anything about climate change unless we do something about how we produce energy.”

Wayland emphasized that while there is a bottleneck in Congress, actions at the state and local levels as well as at the executive level are moving forward. She pointed specifically to new power plant standards, adaptation measures, and renewable energy and energy efficiency targets. But, she said, we need all the help we can get.

“We absolutely have to be doing [this work] with people from the outside,” Wayland said. “Hopefully, we’ll be working with all of you so we can chart a path forward toward transforming our energy system from one that’s dependent on carbon to one that’s dependent on innovation to help us confront the challenges of the 21st century....I hope that includes a growing number of women shepherding that transformation.”

While government actions are one way to lead this transformation, creating consumer demand is another piece of the puzzle, said Brown. “We used to point to the industrial titans, the oil barons, and the utility CEOs as being the biggest part of the problem. But in a sense, you could argue today that consumers are a big part of the problem, and if we can get them to demand clean and green energy choices in the marketplace, then the market will be more responsive.”

Women and clean energy in the developing world

Another goal of the US C3E program is to create a model for other countries. India hosted the fourth Clean Energy Ministerial in April, which included a panel discussion of how to advance women in clean energy, not just at the professional level but also at the community level. A talk by Jyoti Arora from India's Ministry of Power addressed the subject as well as the energy challenges of the developing world.

Arora said women are “often in the driver's seat as entrepreneurs and providers of sustainable energy solutions at the community level”—a point made evident by the considerable number of women entrepreneurs in the audience. Katherine Lucey, one of the award winners, was one of those entrepreneurs.

Lucey's organization, Solar Sister, uses women as their distribution network and equips them to sell solar lanterns and improved cookstoves in their communities. She said the women see a transformation in their communities, as households “go from a solar lamp to a phone charger to a small home system, and they come back and say, ‘Now how am I going to power my TV?’”

Arora said achieving this level of sustainable energy is necessary in the developing world because it “is an enabling factor for economic development, poverty reduction, and for... ensuring environmental sustainability and promoting gender equality.”

India—the world's fourth largest consumer of energy—is paving the way for change by bringing electricity to communities that have never had it before through decentralized systems.



The Energy Technology and Innovation panel, moderated by MITEI Director Robert Armstrong (far right), featured (from left) Renata Mele of the Enel Foundation; Alla Weinstein of Principle Power, Inc.; Marilyn Brown of the Georgia Institute of Technology; and Cheryl Martin of the Advanced Research Projects Agency–Energy (ARPA-E).

Examples include solar streetlights, solar lanterns, improved cook stoves, standalone solar and biomass-based power generation, and wind pumps.

Arora said that the “involvement of women in the design, distribution, management, and consumption of sustainable energy solutions is essential in the quest for clean energy transformation.”

Her comments echoed Sabanci's earlier remarks on the need for women as social agents of change, and the overall sentiment of the C3E program. Empowered by women young and old, from industry to government to the academy, and from the United States to countries throughout the world, C3E unites all women toward the goal of furthering clean energy leadership.

• • •

By Vicki Ekstrom, MITEI

Report maps future of alternative fuel vehicles

Cars that run on alternative fuels like biofuels and liquefied natural gas can cost less, cut emissions, and reduce dependence on foreign fuels, according to a report by the MIT Energy Initiative (MITEI) released on July 10, 2013.

The report examines the future of natural gas, biofuels, and gasoline as fuels for light-duty vehicles over the next two to three decades. Specifically, it studies both “bi-fuel” vehicles able to run on either gasoline or natural gas, and “flex-fuel” vehicles able to run on a blend of gasoline, ethanol, or methanol (or all three simultaneously).

The report is based on a 2012 MITEI Associate Member symposium that brought together experts and policy makers to discuss the prospects for alternative fuel technologies for light-duty vehicles and how an expanded alternative fuel market might be achieved.

“Alternative fuel vehicles could have enormous benefits for our wallets and our health because they are cleaner and potentially cheaper fuels,” says MIT Institute Professor John Deutch, one of the lead organizers of the symposium. “But there is also enormous uncertainty and disagreement surrounding the future of these fuels. This report, and our symposium on the topic, makes this abundantly clear.”

The report points to significant debate among industry, academics, and policy makers about the direction of the market, the potential of future technologies, and the best actions for policy makers. One area of agreement: If alternative fuels are to become competitive in the car market quickly, the new technologies must be able to be introduced into cars that are on the road today.



“Do these alternative-fuel technologies have a sensible path to the marketplace? We’re asking that question, and many more,” Deutch said. “There is much more research that needs to be done in this area—both in terms of developing the technology and understanding the market and policy implications of our actions.”

While the future of alternative fuel vehicles is unclear, the report showed that the need for and potential of these cleaner cars grow more each day for three reasons:

- **Cost less:** Nearly 8% of average household income is spent on gasoline. Alternative fuels would be cheaper and would not be subject to the extreme price volatility of gasoline. Inexpensive to run, these cars would also not be expensive to manufacture. The report estimates that the premium to manufacture cars powered by alternative fuels would be less than a thousand dollars, and possibly much less.

- **Cut emissions:** Gasoline-powered cars comprise nearly one-third of total net US greenhouse gas emissions. Alternative fuel vehicles would give off fewer emissions and would comply with current and anticipated air emission standards.
- **Boost energy security:** Gasoline consumption accounted for more than half of total US petroleum demand in 2011. Although the quantities of petroleum imports have decreased from a peak in 2005, the dollar value has increased. The United States spent \$335 billion on foreign oil in 2011, an increase of 84% from 2005. This oil import bill accounts for more than half of the country’s net trade deficit.

The symposium was sponsored by MITEI Associate Members Cummins, Entergy, EDF, and Hess.

The full report and related white papers are available at mitei.mit.edu/publications/reports-studies/prospects-bi-fuel-and-flex-fuel-light-duty-vehicles. Reports from previous symposia are available at mitei.mit.edu/publications/reports-studies.

• • •

By Vicki Ekstrom, MITEI

Students win with plan to integrate electric cars into grid

Four MIT graduate students won first place in a competition sponsored by the US Association of Energy Economics (USAEE) aimed at tackling today's energy challenges and preparing solutions for policy makers and industry. The students—Ashwini Bharatkumar, Michael Craig, Daniel Cross-Call SM '13, and Michael Davidson, all of the Engineering Systems Division—competed against teams from other North American universities to develop a business model for a hypothetical utility company in California facing uncertain electricity growth from a rise in electric vehicle charging.

“The case competition was a great opportunity to consider solutions to the very challenges that electric utilities are facing today,” Bharatkumar says.

With the goal of minimizing distribution system upgrade costs, the MIT team tested how well several business models or technology alternatives could address the utility company's challenge. The options included implementing a real-time pricing and demand response

program, using battery storage, using controlled charging, or some combination of the three.

The MIT students found that, instead of simply expanding the transmission and distribution network to accommodate the increased demand, the better course of action would be to install advanced metering infrastructure and implement controlled charging to shift the electric vehicle load to off-peak hours. They also recommended modifying the rate structure to include capacity—not just energy—costs. For example, grid users choosing to charge their vehicles during peak hours would incur an additional fee.

The team presented its recommendations at the annual USAEE and International Association for Energy Economics North American Conference in Anchorage, Alaska, on July 29–31, 2013.

• • •

By Vicki Ekstrom, MITEI



First-place winners of the US Association of Energy Economics competition included MIT graduate students (from left) Michael Craig, Michael Davidson, and Ashwini Bharatkumar. Also on the winning team was Daniel Cross-Call SM '13.

Workshop on energy-water-land nexus

On May 6 and 7, 2013, the MIT Energy Initiative (MITEI) held a day-and-a-half-long Energy-Water-Land Nexus Workshop at the Center for Strategic and International Studies (CSIS) in Washington, DC. The workshop, sponsored by MITEI Founding Member BP, brought together the expertise and insights of nearly 200 researchers to create a coherent, forward-looking research agenda on the energy-water-land nexus.

The workshop grew out of a multi-year, multi-university research program that BP has sponsored, known as the Energy Sustainability Challenge (ESC). The goal of the ESC has been to address the key question: How will natural resource constraints change the way we produce energy? Water is recognized as one of the next big issues in the energy industry, and tackling it in a cohesive manner has been difficult.

The workshop was designed to bring together researchers from many of the 13 universities that have been sponsored by this BP program, along with other leading experts with knowledge and understanding of the technology, economics, policy, and systems issues around the constraints, particularly water and land constraints on energy sustainability going forward. The forum allowed interactive discussion among the participants, who had varied opinions.

After the workshop, researchers from MIT and CSIS discussed the findings at the White House Office of Science and Technology Policy. A report will be developed by the end of the academic year.

• • •

By Rebecca Marshall-Howarth, MITEI

New MIT student group focuses on energy and the developing world

Nearly 1.3 billion people live without electricity in the developing world—contributing to other critical social challenges, such as a lack of food and water and adequate healthcare. Seeing the need for a more collaborative approach to confronting the developing world’s energy challenge, students at MIT have started a new group called Energy for Human Development, or e4Dev.

The group formed after Yael Borofsky and Sarah Dimson—two second-year graduate students in the Department of Urban Studies and Planning— independently set out to discover which MIT labs and centers, as well as which students, were coming up with novel ways to confront energy challenges in the developing world. Their individual quests led them to Robert Stoner, deputy director for science and technology at the MIT Energy Initiative (MITEI), and Ignacio Pérez-Arriaga, visiting professor in the Engineering Systems Division, who were both expanding their work on the topic and hoping to involve more students. They encouraged Borofsky and Dimson to form a student group, and, with support from MITEI, e4Dev was born.

“Energy for human development is not only about finding access to electricity, but more broadly the link between energy and development challenges,” says Borofsky, noting that three-quarters of the world’s population still uses just 10% of global energy.

At e4Dev’s launch event, held on September 10, 2013, Borofsky and Dimson hosted a panel of experts, moderated by Stoner, which included Pérez-Arriaga; John Sterman, the Jay Forrester Professor of Management and director of the MIT System



Photos: Dominick Reuter

Yael Borofsky (left) and Sarah Dimson, both graduate students in urban studies and planning, have launched a new student group called Energy for Human Development, or e4Dev. The new group seeks to bring together students, faculty, and practitioners—at MIT and beyond—who are devoted to working on critical issues at the intersection of energy and development.

Dynamics Group; Michael Greenstone, the 3M Professor of Environmental Economics; and Leslie Hook, a *Financial Times* reporter and Harvard Nieman Fellow.

Pérez-Arriaga kicked off the panel discussion saying that in developing communities technology has the greatest capacity to make a change—but that technology must first be adapted to the unique cultures and resources of each location.

While Sterman didn’t disagree, he noted that technological innovation alone won’t fix the problem, because the problem is not lack of access to energy. Instead, the lack of energy access in the developing world is a symptom of much larger problems: world population and economic growth.

“The great challenge is how we create a world in which the poor can realize opportunities and have their basic material needs met in a world that’s already overshoot the sustainable limit,” Sterman said. “That’s the defining issue of our age.”

Technological innovation and changes in the social structure and politics are both needed first steps, Sterman said, but ultimately a transformation of values is needed “to end the quest for more at all costs.”

Hook, who spent time reporting in China, noted that China has been able to find some balance—growing its gross domestic product while keeping poverty levels relatively low. At the same time, the country is making investments in wind, solar, and nuclear energy. Pointing to the country as a

Training and education for energy professionals

model for developing countries to follow, Hook said, “China’s energy needs and demands have actually started to shape development policy instead of the other way around.”

But the challenge for China, as for all developing countries, Greenstone said, will be “finding ways to increase access to energy without unleashing vast environmental problems.”

All of the panelists sent the message Dimson says she hopes e4Dev will help spread—that “although these energy challenges involve a technical question, they fundamentally have a human answer.”



On October 17, 2013, e4Dev held its second event, which focused on “Power Africa,” a major initiative launched by President Obama in July 2013 with a goal of doubling access to power in sub-Saharan Africa by 2030. Discussing the initiative are Andrew Herscowitz, coordinator for Obama’s Power Africa and Trade Africa initiatives (left), and Allen Eisendrath, energy division chief at the US Agency for International Development (center). Robert Stoner, deputy director for science and technology at the MIT Energy Initiative (right), served as moderator during a question-and-answer session.

Along with focusing attention on the critical state of energy in the developing world, e4Dev aims to foster a deeper understanding of how energy affects nearly every economic sector and, more importantly, how it affects people’s lives. Working toward these goals, the group plans to meet weekly to connect, share ideas, debate, and collaborate on solutions.

• • •

By Vicki Ekstrom, MITEI

Week-long opportunities at MIT

Short Programs: Two- to five-day intensive courses provide critical knowledge to help with career advancement and impact your company’s success. Earn Continuing Education Units and a Certificate of Completion. Some courses can be offered at company sites for groups of 25 or more.

Energy courses offered include *Beyond Smart Cities; Design of Motors, Generators, and Drive Systems; Energy, Sustainability, and Life Cycle Assessment; Sustainability; Transportation Networks;* and more.

Additional courses impacting energy industry needs include *Materials by Design* and *Radical Innovation* as well as courses on data modeling, leadership, negotiation, and systems engineering.

Semester-long opportunities

Advanced Study Program (ASP): Enrollment in MIT courses is possible through this non-matriculating, non-degree program. Participate full- or part-time for one or more semesters. Select from more than 2,000 courses and earn grades, MIT credit, and a Certificate of Completion.

ASP participants come from all over the world to spend a semester at MIT taking courses related to the needs of their companies. This is an excellent opportunity for professionals to gain in-depth knowledge in energy via MIT’s wide array of campus-based classes.

To learn more about MIT Professional Education, visit professionaleducation.mit.edu or email professionaleducation@mit.edu.

MITEI Founding and Sustaining Members

MITEI's Founding and Sustaining Members support "flagship" energy research programs or individual research projects that help them meet their strategic energy objectives. They also provide seed funding for early-stage innovative research projects and support named Energy Fellows at MIT. To date, members have made possible 118 seed grant projects across the campus as well as fellowships for nearly 300 graduate students and postdoctoral fellows in 20 MIT departments and divisions.

FOUNDING MEMBERS

BP
Eni S.p.A.
Saudi Aramco
Shell



SUSTAINING MEMBERS

Robert Bosch
Chevron U.S.A. Inc.
Ferrovial
Lockheed Martin
Schlumberger
Total
United Technologies Corporation
Weatherford International Ltd.



Members as of November 15, 2013

MITEI Associate and Affiliate Members

MITEI's Associate and Affiliate Members support a range of MIT energy research, education, and campus activities that are of interest to them. Current members are now supporting various energy-related MIT centers, laboratories, and initiatives; fellowships for graduate students; research opportunities for undergraduates; campus energy management projects; outreach activities, including seminars and colloquia; and more.

Associate Members

Alliance for Sustainable Energy
Booz Allen Hamilton
Cummins
Duke Energy
EDF

Edison International
Enel
Energy
Hess
ICF International

Affiliate Members

8 Rivers Capital
Albachiara Rinnovabili S.r.l.
Angeleno Group
Asociación Nacional de Empresas Generadoras (ANDEG)
Aspen Technology, Inc.
AWS Truepower, LLC
Larry Birenbaum '69
BlackRock
Bloomberg New Energy Finance
John M. Bradley '47, SM '49
Constellation Energy
Cooley LLP
Jerome I. Elkind '51, ScD '56
EnerNOC, Inc.
Ernst & Young LLP
Dennis Fromholzer
Fundació Barcelona Tecnologia (b_TEC)
Gas Technology Institute
General Electric
Natalie M. Givans '84
C. Gail Greenwald
Thomas Guertin PhD '60
Harris Interactive
Hogan Lovells US LLP
IHS Cambridge Energy Research Associates
Paul Mashikian '95, '97

Massachusetts Clean Energy Center
New York State Energy Research and Development Authority
Nexant, Inc.
NGP Energy Technology Partners, LP
Open Access Technology International, Inc.
Osaka Gas Co., Ltd.
Patriot Renewables
Petra Energia S.A.
Praxair, Inc.
Pythagoras Investment Management, LLC
Joseph M. Rault '48, President, Rault Resources Group
Redpoint Ventures
Philip Rettger '80
Rockport Capital Partners
S. Kinnie Smith, Jr.
Doug Spreng '65
Steptoe and Johnson, LLP
George R. Thompson, Jr. '53
The Tremont Group, LLC
Tomas Truzzi
Walmart
Westport Innovations, Inc.
Xandex, Inc.



MIT Energy Initiative
Massachusetts Institute of Technology
77 Massachusetts Avenue, E19-307
Cambridge, MA 02139-4307



Return service requested

Nonprofit Organization
U.S. Postage

PAID
Cambridge, MA
Permit No. 54016

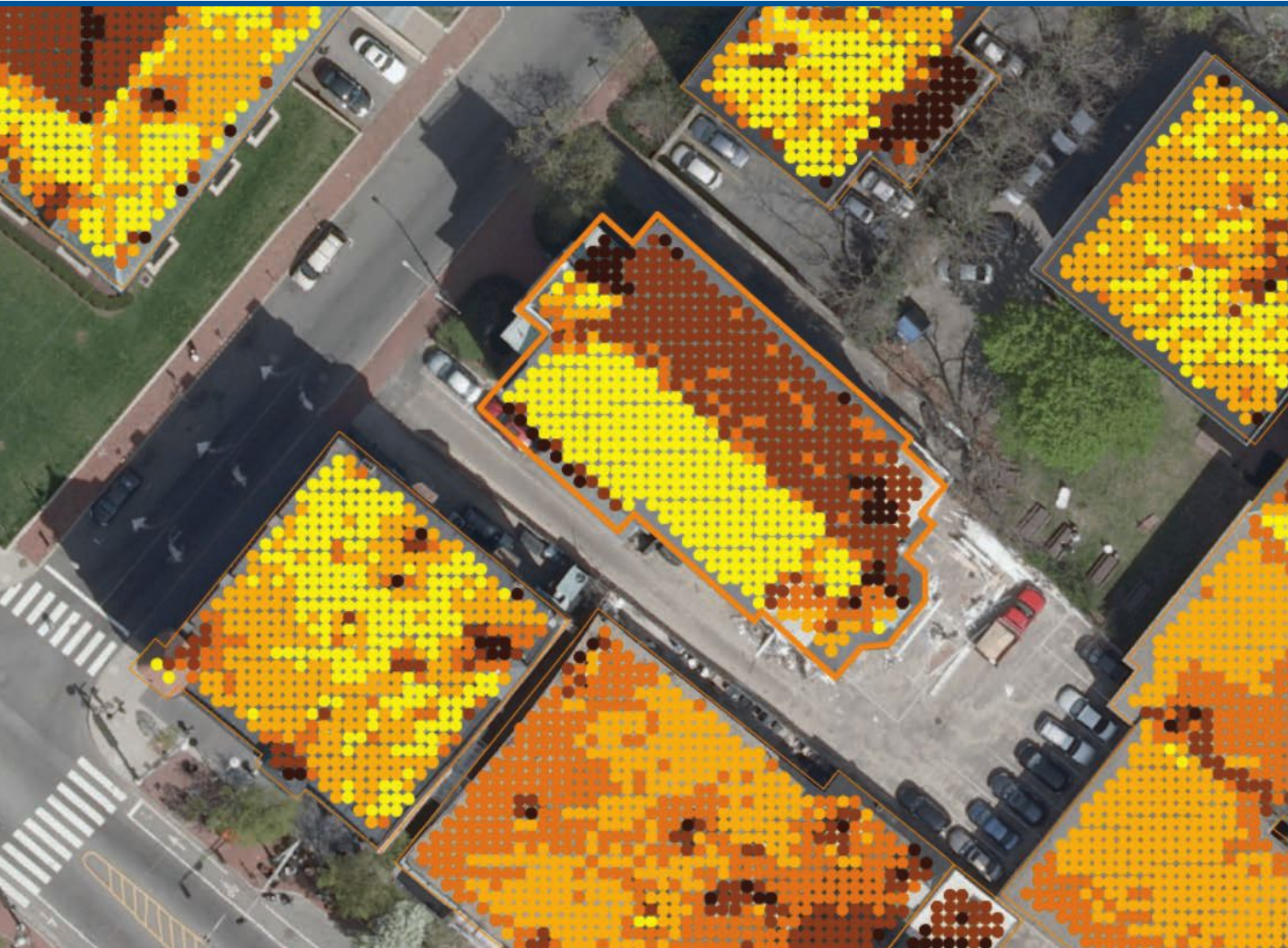

Urban sustainability: Designing resource-efficient, appealing cities

Researchers in MIT's Sustainable Design Lab and their collaborators have mapped the solar potential of more than 17,000 rooftops in Cambridge, Massachusetts. In the image above, the brightness of the colored dots indicates how well solar panels would perform on specific areas of each rooftop in this neighborhood. A publicly accessible tool allows users to specify a street address and find out the optimal size for a solar installation along with its cost, payback time, technical details, and environmental impacts. (For the online solar map, go to en.mapdwell.com/solarsystem/cambridge.) In other work, the MIT team has developed models that can assess specific urban designs for energy efficiency, environmental impacts, outdoor comfort, walkability, and more. For more information, see page 4.