

Energy Futures

MIT ENERGY INITIATIVE

MIT

SPRING 2013



Building façades that move, textiles that illuminate

IN THIS ISSUE



MIT's Ernest J. Moniz becomes Secretary of Energy



Exploring energy game changers: Moving technologies from lab to marketplace

Yang Shao-Horn: Catalyzing the next generation of batteries

Tata Center students spot opportunities to innovate in India

the 1990s, the number of people in the world who are undernourished has increased from 600 million to 800 million.

There are a number of reasons for this increase. One of the main reasons is the rapid population growth in the developing countries. The world population is expected to reach 8 billion by the year 2025, and this increase will be concentrated in the developing countries. This will put a tremendous pressure on the world's food resources.

Another reason for the increase in undernourishment is the rapid increase in the number of people who are living in urban areas. This is because of the migration of people from rural areas to urban areas in search of better living conditions. This migration has led to a concentration of people in urban areas, which has put a strain on the urban food supply.

A third reason for the increase in undernourishment is the rapid increase in the number of people who are living in poverty. This is because of the rapid increase in the number of people who are living in the informal sector of the economy. This informal sector is characterized by low wages and poor working conditions, which has led to a concentration of people in poverty.

There are a number of ways in which the world can address the problem of undernourishment. One of the most important ways is to increase the production of food in the developing countries. This can be done by increasing the use of modern agricultural techniques and by providing better access to credit and other services for farmers.

Another way to address the problem of undernourishment is to improve the distribution of food. This can be done by reducing the number of people who are living in poverty and by providing better access to food for the poor. This can be done by increasing the minimum wage and by providing better social services for the poor.

A third way to address the problem of undernourishment is to reduce the number of people who are living in urban areas. This can be done by providing better living conditions in rural areas and by encouraging people to stay in rural areas. This can be done by providing better access to credit and other services for farmers and by providing better social services for the rural population.

There are a number of other ways in which the world can address the problem of undernourishment. These include increasing the use of modern agricultural techniques, providing better access to credit and other services for farmers, and providing better social services for the poor. These are all ways in which the world can address the problem of undernourishment and ensure that everyone has access to enough food to live a healthy and productive life.

The world must take action now to address the problem of undernourishment. If we do not, the number of people who are undernourished will continue to increase, and this will have a devastating impact on the world's food resources. We must take action now to ensure that everyone has access to enough food to live a healthy and productive life.

The world must take action now to address the problem of undernourishment. If we do not, the number of people who are undernourished will continue to increase, and this will have a devastating impact on the world's food resources. We must take action now to ensure that everyone has access to enough food to live a healthy and productive life.

The world must take action now to address the problem of undernourishment. If we do not, the number of people who are undernourished will continue to increase, and this will have a devastating impact on the world's food resources. We must take action now to ensure that everyone has access to enough food to live a healthy and productive life.

The world must take action now to address the problem of undernourishment. If we do not, the number of people who are undernourished will continue to increase, and this will have a devastating impact on the world's food resources. We must take action now to ensure that everyone has access to enough food to live a healthy and productive life.

The world must take action now to address the problem of undernourishment. If we do not, the number of people who are undernourished will continue to increase, and this will have a devastating impact on the world's food resources. We must take action now to ensure that everyone has access to enough food to live a healthy and productive life.

Energy Futures

Energy Futures is published twice yearly by the MIT Energy Initiative. It reports on research results and energy-related activities across the Institute. To subscribe, send your address to stauffer@mit.edu.

Copyright © 2013
Massachusetts Institute of Technology. For permission to reproduce material in this magazine, please contact the editor.

Nancy W. Stauffer, editor
stauffer@mit.edu
617.253.3405

ISSN 1942-4671
(Online ISSN 1942-468X)



MIT Energy Initiative

The MIT Energy Initiative is designed to accelerate energy innovation by integrating the Institute's cutting-edge capabilities in science, engineering, management, planning, and policy.

MIT Energy Initiative
Massachusetts Institute of Technology
77 Massachusetts Avenue, E19-307
Cambridge, MA 02139-4307

617.258.8891
mitei.mit.edu



Main cover image: KVA MATx (see page 17)
Design: Tim Blackburn
Proofreading: Kathryn M. O'Neill
Printing: Puritan Press, Inc.

Printed on paper containing 30% post-consumer recycled content, with the balance coming from responsibly managed sources.

UPDATES ON THE MIT ENERGY INITIATIVE

- 2** MIT's Ernest J. Moniz becomes Secretary of Energy
- 2** Robert C. Armstrong named director of MIT Energy Initiative
- 3** A letter from the director

RESEARCH REPORTS

- 4** Energy-efficient computing: Enabling smaller, lighter, faster computers
- 8** Underground storage of CO₂: Creating more-accurate images at lower cost
- 12** Large-scale irrigation: Understanding energy-water-food connections
- 17** Building façades that move, textiles that illuminate
- 22** Transparent solar cells: Generating power from everyday surfaces

RESEARCH NEWS

- 27** MIT Energy Initiative announces latest seed grant awards
- 28** Best poster awards
- 29** Recipients of MITEI seed grants, spring 2013
- 30** Novel slippery surfaces: Improving steam turbines and ketchup bottles

FOCUS ON FACULTY

- 32** Yang Shao-Horn: Catalyzing the next generation of batteries

EDUCATION

- 34** Bringing science to life: Undergrads learn by seeing, doing in 3.012
- 36** Energy IAP: Preparing for and adapting to climate variability
- 39** Energy classes pass 1 million online visits
- 40** Energy alumni: Where are they now?
- 43** The MIT Energy Club: Building the energy community on campus and beyond
- 45** Tata Center students spot opportunities to innovate in India

CAMPUS ENERGY ACTIVITIES

- 48** Energy savings add up to success for Efficiency Forward
- 50** MIT plans energy-saving upgrades to Main Group

OUTREACH

- 51** Exploring energy game changers: Moving technologies from lab to marketplace
- 53** At MIT, Gov. Deval Patrick highlights clean-energy achievements
- 54** IEA Outlook forecasts upheaval in worldwide energy system

LFEE • LABORATORY FOR ENERGY AND THE ENVIRONMENT

- 55** Martin Fellows, 2013–2014

MITEI MEMBERS

- 56** MIT and Eni renew energy partnership
- 57** MITEI Founding, Sustaining, Associate, and Affiliate Members

MIT's Ernest J. Moniz becomes Secretary of Energy

Photo: Justin Knight



Ernest J. Moniz, the founding director of the MIT Energy Initiative (MITEI), left the Institute in spring 2013 to lead the US Department of Energy (DOE). He stepped down from his longtime positions as the Cecil and Ida Green Professor of Physics and Engineering Systems and as the director of MITEI and of the Laboratory for Energy and the Environment.

In his speech nominating Moniz, President Obama noted his unique qualifications, saying, "Ernie knows that we can produce more energy and grow our economy while still taking care of our air, our water, and our climate. I could not be more pleased to have Ernie join us."

As Secretary of Energy, Moniz oversees an agency devoted to ensuring America's security and prosperity by addressing its energy, environmental, and nuclear challenges through science and technology. The agency had a budget of more than \$29 billion in fiscal year 2012; runs 17 national laboratories and many other research facilities; and has more than 16,000 federal employees and 90,000 contract employees at the national laboratories and other facilities. DOE is also the largest funder of research in the physical sciences.

MIT President L. Rafael Reif said, "President Obama has made an excellent choice in his selection of Professor Moniz as energy secretary. His leadership of MITEI has been in the best tradition of the Institute—MIT students and faculty focusing their expertise and creativity on solving major societal challenges, a history of working with industry on high-impact solutions, and a culture of interdisciplinary research." Reif continued, "We have been fortunate that Professor Moniz has put his enthusiasm, deep understanding

of energy, and commitment to a clean energy future to work for MIT and the Energy Initiative—and we are certain he will do the same for the American people."

Moniz served as undersecretary of energy from 1997 to 2001. In that role, he had oversight responsibility for all of DOE's science and energy programs and the DOE national laboratory system. He also led a comprehensive review of the nuclear weapons stockpile stewardship program, advanced the science and technology of environmental cleanup, and served as DOE's special negotiator for Russia initiatives, with a particular focus on the disposal of Russian nuclear materials.

From 1995 to 1997, he served as the associate director for science in the White House Office of Science and Technology Policy. There, his responsibilities spanned the physical, life, and social and behavioral sciences; science education; and university-government partnerships.

Moniz has also served on the President's Council of Advisors for Science and Technology, the Department of Defense Threat Reduction Advisory Committee, and the Blue Ribbon Commission on America's Nuclear Future.

Moniz has been on the MIT faculty since 1973. He served previously as head of the Department of Physics and as director of the Bates Linear Accelerator Center. His principal research contributions have been in theoretical nuclear physics and in energy technology and policy studies.

Robert C. Armstrong named director of MIT Energy Initiative

On May 16, 2013, Robert C. Armstrong became director of the MIT Energy Initiative (MITEI), replacing Ernest J. Moniz. Armstrong has served as the deputy director of MITEI since its founding six years ago. He was co-chair (with Moniz) of the Energy Research Council that laid the groundwork for MITEI and set its guiding principles. Armstrong, the Chevron Professor of Chemical Engineering, has since played a leading role in the Initiative's development.

"Professor Armstrong has been a guiding force in the development and success of the MIT Energy Initiative," MIT President L. Rafael Reif said. "He helped shape its transformation from a promising idea into a pioneering source of energy research, policy analysis, and education. Under Professor Armstrong's leadership, MITEI will continue its bold interdisciplinary approach to developing global energy solutions, and it will remain a vital force in MIT's innovation ecosystem. Given Professor Armstrong's superb technical grounding and his strong relationships with research partners in industry, government, and philanthropy, we look forward to this new era at MITEI with the greatest confidence and optimism."

Maria Zuber, MIT vice president for research, said, "Professor Armstrong's broad and deep knowledge of energy, combined with his strong commitment to energy research and education, make him the ideal choice to take the reins at MITEI. I'm looking forward to continuing to work closely with him to further strengthen and spread energy research across the Institute."

Armstrong has been a member of the MIT faculty since 1973 and was head of the Department of Chemical Engineering from 1996 to 2007. He was elected into the National Academy of Engineering in 2008 and has received awards from the American Institute of Chemical Engineers.

A letter from the director

Dear Friends,

At its founding, the MIT Energy Initiative (MITEI) was designed to be a flexible, robust, and responsive platform for highly focused energy-related research and education. This design is serving us well during this time of enormous transition at both the macro level, where the range of energy challenges is always dynamic, and the micro level, where we've undergone a change in leadership at MITEI.

Ernie Moniz's departure as director of the Initiative is a loss for MIT and MITEI, but a major gain for the nation's energy future. While I'm sad to see my friend and colleague go, I'm both proud and excited to take the reins as the new director of MITEI—proud of our accomplishments and excited for the future of the Initiative as we work together to meet global energy challenges.

At the macro level, the energy profile of the United States—and the world—is going through dramatic changes. Enabled by new technologies, the US now has access to some of the largest unconventional oil and gas resources in the world. The availability of those resources provides clear energy security benefits for the US, and can help the world—especially the emerging economies—meet an increasing demand for energy. But taking advantage of those resources could exacerbate the environmental and climate impacts of global energy production and use.

We saw last fall the impact a changing climate can have when "Superstorm Sandy" caused horrible devastation, at the same time highlighting the fragility of our energy infrastructures and networks. More recently, and certainly related to events like Sandy, the world crossed a critical threshold: Carbon

dioxide concentrations in the atmosphere now exceed 400 ppm, a level at which we can expect to see more frequent and severe impacts from a changing global climate.

MITEI's research agenda is responsive to those realities. One of the Initiative's key drivers has always been to help move the world toward a low-carbon energy future. At the research level, this goal has translated into a focus on innovations in existing energy technologies and systems, and on transformational low- or no-carbon energy technologies. At last count, more than two-thirds of the research projects supported through MITEI focused on such no- or low-carbon technologies as renewable energy, energy efficiency, and carbon management, and on such key enabling tools as biotechnology, nanotechnology, and advanced modeling and simulation capabilities.

While continuing this important research, we're extending our dual-track strategy—innovation and transformation—as we work to establish new strategic directions. With help from across the Institute, we have identified the following areas for expanded attention in research: energy conservation and efficiency in the built environment; energy requirements for water and water requirements for energy; the need for a more resilient, secure, and smart electric grid; and the contributions of life sciences to a low-carbon future.

As we enhance and expand our research priorities, we also continue to foster energy education across campus. With the June 2013 class, students from all five of MIT's schools have graduated with the Energy Studies Minor—a demonstration of our fundamental belief that energy

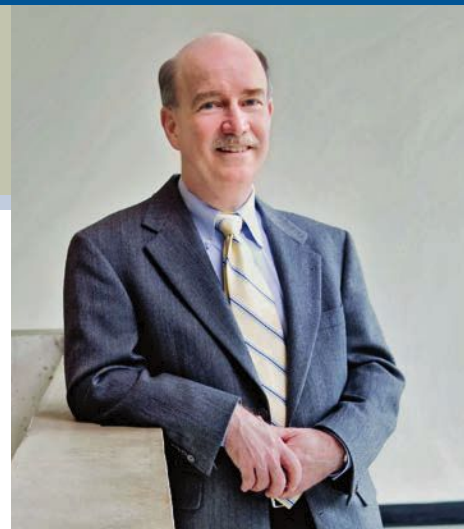

Photo: Webb Chappell

MITEI's research, education, campus energy, and outreach programs are spearheaded by Professor Robert C. Armstrong, director.

education must be cross-cutting. Looking forward, the long-term sustainability of the Energy Studies Minor appears bright due to an anonymous gift establishing an endowed fund to support teaching within the program.

With the continued strong support of MIT President L. Rafael Reif and Maria Zuber, MIT's new vice president for research, MITEI is moving forward. As always, we're committed to performing innovative and transformational research; working with our members to bring energy solutions to the marketplace; educating the next generation of energy experts; making our campus a model of efficient energy use; and providing policymakers with the unbiased, technically based analyses they need to make informed decisions.

Thank you for your support and interest. We hope you enjoy this eleventh edition of *Energy Futures*, which reflects a snapshot of the work that will drive our energy future forward.

Robert C. Armstrong

Professor Robert C. Armstrong
MITEI Director

June 2013



Energy-efficient computing

Enabling smaller, lighter, faster computers

Erik D. Demaine (right) and Jayson R. Lynch of electrical engineering and computer science are developing novel designs for computer hardware and software that will substantially reduce the rapidly growing use of energy for computing while also making possible smaller, lighter, faster laptops and mobile devices.

This research was supported by a seed grant from the MIT Energy Initiative.

Photo: Stuart Darsch

A theoretical computer scientist and his MIT colleagues are finding ways to reduce the energy used in computation—a change that could lead to laptops and mobile devices that are smaller and lighter, generate less heat, and perform complicated calculations with unprecedented speed. The researchers have proved mathematically that relatively simple hardware modifications could cut in half the energy consumed in running today's standard software procedures. And they have shown that coordinated changes in software and hardware could increase the energy efficiency of computing by a million times. The researchers have already written new energy-efficient algorithms for everyday tasks such as searching and sorting that—when run on specially adapted computer hardware—should deliver substantial energy savings. And even greater savings will come with new energy-efficient procedures for processing big data, for example, during web searches.

Most developers of computer software and hardware focus on solving problems with maximum speed and minimum storage space. But energy use for computing is an increasing concern, according to Erik D. Demaine, professor of electrical engineering and computer science. Worldwide, 3 billion personal computers use more than 1% of all energy consumed, and 30 million computer servers use an added 1.5% of all electricity at an annual cost of \$14 billion to \$18 billion. Expanded use of the Internet, smart phones, and computation in general is causing all of those numbers to escalate. Making computation more energy-efficient would save money, reduce energy use, and permit batteries that provide power in mobile devices to run longer or be smaller, says Demaine. In addition, computers would generate less heat, so calculations could run faster. Indeed, cutting energy use in half would halve heat output or double the processing speed.

Over the past 70 years, the energy efficiency of computers has increased steadily. In central processing units (CPUs)—the main brain of the computer—computations per kilowatt-hour have doubled every 1.5 years or so. And graphics processing units have improved even more quickly. But that trend will end. “Landauer’s principle”—proved theoretically in 1961 by Rolf Landauer and recently reconfirmed experimentally—places a fundamental upper limit on how many computations can be performed per kilowatt-hour. “With current approaches to computation, we estimate that we’ll hit a wall in a few decades, and efficiency won’t get any higher,” says Demaine. “So we need to develop a new way to think about computation.” He and his colleagues in the MIT Computer Science and Artificial Intelligence Laboratory have been doing just that.

Sample logic gate

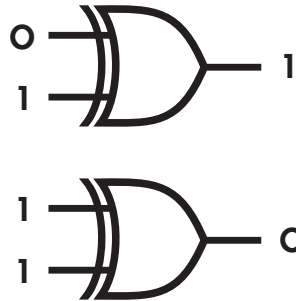

A major source of wasted energy and heat dissipation in computers is illustrated by this “logic gate,” a building block for computational procedures that is implemented by hardware such as transistors. All information inside a computer is represented by either a 1 (indicated by 1 volt) or a 0 (indicated by the absence of voltage). In the top example, one 1 enters the gate and one 0 leaves it. No voltage is wasted. In the bottom example, two 1’s enter, but only a 0 exits. The voltage representing those 1’s must be discarded, causing the gate to dissipate heat, slowing the computation and wasting energy.

Reduce energy use, cut generated heat

Finding ways to reduce energy use requires looking at the basic processes that go on inside a computer. The basic unit of information in all computation is a “bit” (short for “binary digit”). Each bit can have only one of two values—a 1 or a 0—and they are differentiated by voltage. A 1 is represented as a positive voltage—say, 1 volt—and a 0 by the absence of voltage. Running a computation involves turning 1’s into 0’s and vice versa, and some of those transitions waste energy.

The diagram above illustrates the problem. The symbol is a typical “logic gate,” an elementary building block of a digital circuit. Assume the question being asked is: Are these two inputs different? In the top example, the inputs are 0 and 1, so the answer is yes, which by convention is represented by a 1. In this case, the same number of 1’s came out as went in. In the lower example, the inputs are two 1’s, so the answer is no, which is represented by a 0. Since 0 is represented by the absence of

voltage, the 2 volts that were invested in creating those two 1’s are literally thrown away, and that wasted energy is dissipated as heat. (Conversely, one can focus on supplying voltage to make the 1’s, but chipmakers are generally more concerned about destroying 1’s because waste heat creates problems.)

So finding a way to conserve 1’s and 0’s throughout every computation would cut wasted energy, reduce heat loss, speed up processing, and increase energy efficiency, potentially even beyond Landauer’s theoretical limit.

Modified hardware for reduced energy use

According to Demaine, a step in the right direction is through “conservative computing.” This strategy requires only hardware modifications—no need to change current software procedures—and it seeks to preserve only the 1’s. The number of 0’s is of no concern.

To implement conservative computing, Demaine and graduate student Jayson R. Lynch of electrical engineering

Dual-rail logic

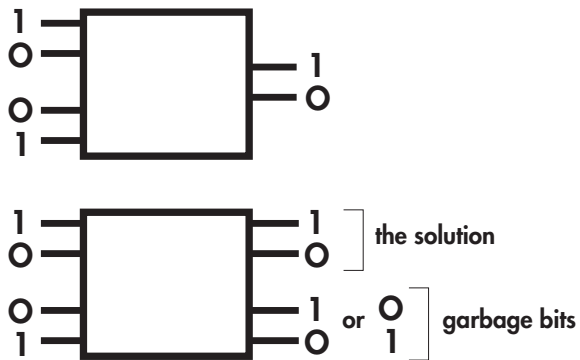

To save energy, reduce heat loss, and speed up computation, MIT researchers have designed a novel approach based on dual-rail logic, a 20-year-old idea for circuit design. Here, 1's and 0's are represented not by single numbers but by 1-0 pairs, with the order defining the value. In the top example above, a 1 is lost, which wastes energy and heat. The bottom example shows the team's solution: The extra inputs are retained as "garbage bits," and the 1 is recycled for use in other decision points in the processor.

and computer science developed an approach based on "dual-rail logic," an idea for circuit design that has been around for 20 years but has never been put into practice. In dual-rail logic, 1's and 0's are not represented by single numbers but rather by pairs: 1-0 and 0-1. So the key is the order in which the numbers appear, not their individual values.

In the top example above, the inputs are 1-0 and 0-1, and the output is 1-0. That setup is wasteful: An incoming 1 is lost during the computation. The researchers solve that problem by retaining the extra inputs as "garbage bits" that carry useless information (see the bottom example). The 1-0 order doesn't matter, but now the number of 1's is preserved after the computation. Since a 1 can never be thrown out, the 1's in the garbage bits must be recycled to some other decision point in the processor. "So it's kind of like a hot potato," says Demaine. "Eventually that

1—that volt—will be needed somewhere, but it might move around awhile until it finds a place where it is actually useful."

"Because we only have to conserve the number of 1's and not all the information, recycling garbage in this case is relatively easy," says Demaine. "And what we proved is that it can always be done." He and Lynch showed mathematically that with relatively simple hardware modifications, it's possible to make any computation conservative.

This novel approach won't eliminate all the wasted energy in today's chips, but their analyses suggest that it should cut energy use and heat loss in half. Demaine hopes to test that estimate by performing simulations or—better still—by building chips with his electrical engineering colleagues at MIT.

One downside of their approach is that the hardware modification would

require more wires and transistors. The added area could increase heat production, offsetting some of the gains from their reduction in wasted energy. But Demaine notes another benefit: The change could increase security. One way to "attack" a computer is to take external voltage measurements, figure out how much and where energy is consumed, and then reverse engineer the processes going on inside. "With conservative computing, energy will be more uniformly distributed, so computations will be harder to observe from the outside," says Demaine. "Companies may want to [implement our approach] for security reasons—and then as a benefit they'd also get the energy improvement."

Energy-efficient algorithms

Even with conservative computing, energy-efficiency gains will stall in several decades. According to Demaine, the key to breaking Landauer's limit is to rethink algorithms—the step-by-step procedures at the core of all software programs. Various algorithms may solve a given computational problem, but they may differ substantially in the amount of time, memory, and energy they use to do it. In the past, the "algorithms community" has not focused explicitly on minimizing energy use. As a result, in many standard algorithms, every decision point involves replacing all the inputs with the newly computed outputs. "So the inputs—millions of bits—are simply being thrown away at every step," says Demaine. "There's a ton of wastage and lots of room for improvement in today's software."

To tackle that problem, Demaine and his colleagues developed a new field of study called energy-efficient algorithms.

By changing both the software and the hardware, they're trying to ensure that algorithms are optimal (or roughly optimal) with respect to energy as well as time and memory. On the energy front, the goal is to conserve all information—not just the 1's but the 0's as well.

Their approach is based on “reversible computing,” an idea first proposed in the 1970s. A reversible algorithm is one that can run either forward or backwards. “It's a sort of logical notion that you could compute the inputs from the output just as well as you could compute the output from the inputs because you haven't lost anything,” Demaine explains. “You don't actually have to run it backwards; it just needs to be possible.”

He offers a simple physical analogy. Two billiard balls are coming at each other in a frictionless world. The first hits the second, transferring all its energy as it does so. Because no energy has been lost (in this perfect world), the second ball could then return and hit the first, transferring all the energy back again, and the billiard balls would go back to their original positions. That's a reversible event—even though it may not happen.

Reversible algorithms behave the same way. “If you can play everything backwards, then no energy has escaped during your computation,” says Demaine. “That's good news. It means we can effectively sidestep Landauer's principle.” While conservative computing may enable programs to run twice as fast, reversible computing could enable them to run millions of times faster.

Using specially devised theoretical models, Demaine and Lynch have spent

the past six months analyzing basic algorithms to see whether they can be made reversible—or more reversible. (There's a fundamental limit on how reversible some algorithms can be.) Already they've found more-efficient replacements for some algorithms used in everyday computational tasks such as sorting, searching, and finding the shortest path between two points in a network. One example is “binary search trees,” which are procedures for organizing data so the data can be retrieved quickly. According to Demaine, binary search trees are used in nearly every computer ever made, and they involve millions of functions and a lot of energy consumption. “But with a couple of tricks, we got energy use down to zero,” he says. “With the new algorithms, we require only the energy needed to store the data, no additional energy to organize it.”

Demaine is pleased with their progress. “It's like starting over,” he says. “Take all the algorithms you learned in your undergraduate class and throw them out the window, or look at all existing algorithms and say, OK, this is bad, let's make it better.” And their results so far “just scratch the surface of what's possible,” he says, noting in particular the huge potential for energy savings in procedures used for processing big data, such as when running network routers or performing web searches.

Hardware to make it happen

There is one catch with the new algorithms: They need to run on a reversible computer—a computer in which all chips and circuits perform reversible functions with no transfer of heat to or from their surroundings. In the 1990s, a group at MIT built preliminary hardware proving such “adiabatic” computing

possible, and recently a company called AMD made a CPU that has a reversible component in it, specifically, the “clock,” which tells the computer to take some action 4 billion times each second.

Demaine finds release of the new reversible clock encouraging. “We think if we can show theoretically that there are really big wins on the software side, then lots of people will begin to build reversible chips,” he says. “Given the opportunities for improvement, our goal is to have computers spend a million times less energy. That's pretty exciting.”

• • •

By Nancy W. Stauffer, MITEI

[This research was supported by a seed grant from the MIT Energy Initiative \(MITEI\). A new MITEI seed grant focuses on developing energy-efficient procedures for processing big data. Publications are forthcoming.](#)



Underground storage of carbon dioxide

Creating more-accurate images at lower cost

Left to right: Michael Fehler, Di Yang, and Alison E. Malcolm, all of earth, atmospheric, and planetary sciences and the Earth Resources Laboratory, have devised a new technique for generating images of carbon dioxide that has been injected into geological formations deep underground—one proposed approach to mitigating climate change.

This research was supported in part by a seed grant from the MIT Energy Initiative. See page 11 for a complete list of sponsors.

Photo: Stuart Darsch

MIT geophysicists are developing lower-cost, more-accurate techniques for imaging and monitoring carbon dioxide (CO₂) injected into underground geological formations for long-term storage. Standard methods used by industry to image the subsurface involve tracking sound waves sent into the earth. However, it is expensive to process the gathered seismic data, and differences in survey conditions such as equipment location and weather make comparing data collected before and after CO₂ injection difficult. The new MIT technique requires significantly less data processing than conventional methods do, and it incorporates several steps that reduce the confusing effects of data-gathering inconsistencies. As a result, it produces clearer images of the subsurface that focus especially on the area of interest. Initial field tests confirm the viability of the technique.

One approach to mitigating climate change while carbon-free energy options are being developed is to capture CO₂ emissions from power plants and other major sources and store them underground, sequestered from the atmosphere. Promising underground formations for storage include deep saline aquifers, depleted oil and gas reservoirs, and unminable coal seams. But widespread adoption of that approach will require reliable techniques for determining the amount and location of the sequestered CO₂ and for monitoring it for potential leaks, which could allow the greenhouse gas to escape back into the atmosphere.

“The oil and gas industry has seismic-based methods that we expect could be adapted to perform those tasks,” says Alison E. Malcolm, the Atlantic Richfield Career Development Assistant Professor in the Department of Earth, Atmospheric, and Planetary Sciences (EAPS). The methods involve using large trucks or other sources to send sound waves deep into the earth. How those seismic waves are reflected by underground layers provides information that sophisticated signal-processing techniques can turn into three-dimensional images of the subsurface. “Performing such analyses before and after CO₂ injection can help to delineate the spatial distribution of the CO₂ in a reservoir,” says Malcolm. “But the high cost of those procedures and the huge computational resources required will likely preclude their use at every sequestration site.”

By adapting conventional seismic-based methods, Malcolm and her colleagues in the MIT Earth Resources Laboratory—Michael Fehler, EAPS senior research scientist, and Di Yang, EAPS graduate student and a 2009-10 Eni-MIT

Energy Fellow—in collaboration with Lianjie Huang of Los Alamos National Laboratory, have been developing a new technique that should not only cost less but also produce images that are clearer and more easily understood.

Models of the subsurface

During a seismic survey, the sound waves generated by exploding dynamite, a huge vibrating truck, or some other source travel downward through the geologic layers and are reflected back to an array of receivers located in the region of the source. During their travels through the subsurface, the sound waves move at varying speeds. For example, their velocity is lower through a soft layer than through a more rigid layer. Velocity generally increases with depth, and it changes abruptly at interfaces between layers.

Because of those variations, the timing and amplitude of the returned signals measured by the receivers can be processed to generate images such as the examples on page 10. Those images show the velocity of the seismic wave created by a source as a function of position beneath the earth’s surface. While color represents seismic velocity, it is in essence representing the geologic layers, so the overall image serves as a proxy for a physical model of the subsurface.

In the carbon-sequestration application, the aim is to look for local changes in velocity that occur as a result of CO₂ injection. The left-hand diagram on page 10 is a “baseline model,” which represents the subsurface before the CO₂ is injected. The right-hand diagram is a “time-lapse” model of the subsurface after CO₂ injection. In the time-lapse model, there is a semicircular

region of anomalous wave speed just below center—a new feature indicating the reservoir of injected CO₂.

While this pair of images is useful, a single image showing just the velocity differences between the baseline model and the time-lapse model should—in theory—provide greater focus on the new CO₂ reservoir and assist in efforts to characterize and monitor it. The researchers’ new technique is a novel approach to calculating such an image.

To test their technique, they needed to perform parallel tests using the conventional method and their new technique. If they started with seismic data from field surveys to make the comparison, they would have no way of knowing which approach came closer to the “correct” answer. So to begin, they created the models shown on page 10. They next worked backward from those models and numerically generated (estimated) sets of “synthetic” seismic data that could yield those models under field conditions.

Now they were ready to perform their comparison. First they used a conventional method to generate an image of velocity change: They processed the before-injection and after-injection synthetic seismic data to generate a baseline model and a time-lapse model, and then they subtracted the former from the latter.

The result is shown in the left-hand figure on page 11. Here color is the change in wave velocity (as a function of position) from before the CO₂ injection to after. The semicircular velocity change inside the reservoir is evident but not detailed or distinct. In addition, there are many small changes away from the reservoir that

Models of the subsurface before and after CO₂ injection

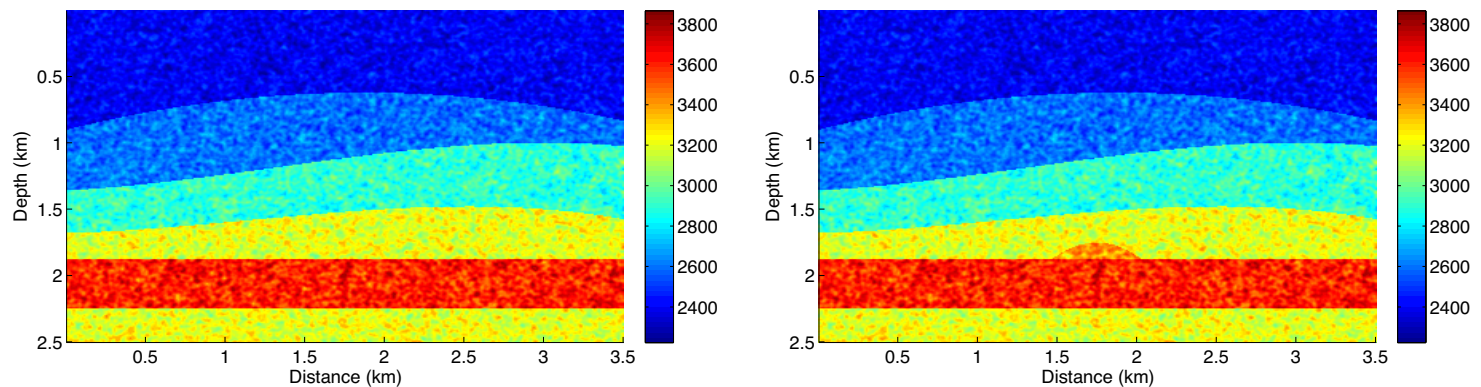

To test their method, the researchers created these models of the earth's subsurface before (left) and after (right) CO₂ injection. The colors represent velocity of the seismic wave (in meters/second) as a function of position—essentially a mapping of the sub-geologic layers beneath the earth's surface. In the right-hand model, the semicircular region of anomalous wave speed indicates the presence of the injected CO₂.

make interpretation confusing: Do they reflect small-scale, isolated geological structures that affect velocity—or might they instead be caused by isolated pockets of CO₂?

The researchers next performed the same analysis using their technique—“double-difference waveform inversion”—which was first suggested by Huang and is now being refined and applied by Malcolm and Fehler's team. The first step was to calculate a baseline model in the conventional way—by processing the before-injection synthetic seismic data. But rather than then generating the time-lapse model, they next subtracted the baseline data from the time-lapse data, thereby producing a new data set of the changes in velocity. By processing those data, they directly generated the desired outcome—a model showing changes in velocity in the subsurface.

The right-hand figure on page 11 shows their result. The image inside the reservoir is now clearer, and there are fewer scattered velocity changes elsewhere. “You'll see that we've recovered fairly well this kind of semicircular change in velocity,” says Malcolm. “By using the difference between the before and after data sets,

we focus in on the change in the reservoir with less noisy scatter outside it.”

Advantages of the double-difference technique

Why does the double-difference technique work so much better? One challenge here is that conditions change between the data-gathering expeditions. “This is not a lab experiment where you're sitting inside and you can control all of the parameters,” says Malcolm. “You're outside. It might rain during the first survey and not the second, or there might be intermittent noise from active drill rigs.” Also, it is difficult to get the receivers and—especially—the source in exactly the same locations. (The source of their test data is a 4-meter-long, 60,000-pound truck. Relocating the central vibration pad in precisely the same place can be tricky.) All of those inconsistencies introduce systematic error in the data—not just within the reservoir, where changes have actually occurred, but also outside it.

In addition, there are small-scale structures throughout the subsurface that cause changes in velocity but are difficult to resolve with certainty in a model. Translating seismic data into a model involves “waveform inversion,”

an optimization process that identifies the model that best approximates most of the wave events in the seismic data. However, as in any optimization process, there are many models that could fit the data. With the conventional approach, the two independent inversions may not resolve those small-scale structures in an identical manner. Subtracting the two models therefore yields apparent changes in velocity that result from those different interpretations. “The subtraction produces a ‘noisy’ image that reflects the poor resolution of each independent inversion,” says Malcolm.

Using differences in the data rather than the models enables Malcolm and her team to take steps to reduce those sources of inconsistency. “The data really see the earth, not whatever our model is,” says Malcolm. “The only thing that actually changed in the earth...is in the reservoir region.” They therefore infer that changes in the data for regions well away from the reservoir must be caused by changes in the survey conditions, such as weather or equipment location. Based on that knowledge, they create a filter that removes that systematic error from the entire data set—outside as well as inside the reservoir.

Change in wave velocity after CO₂ injection

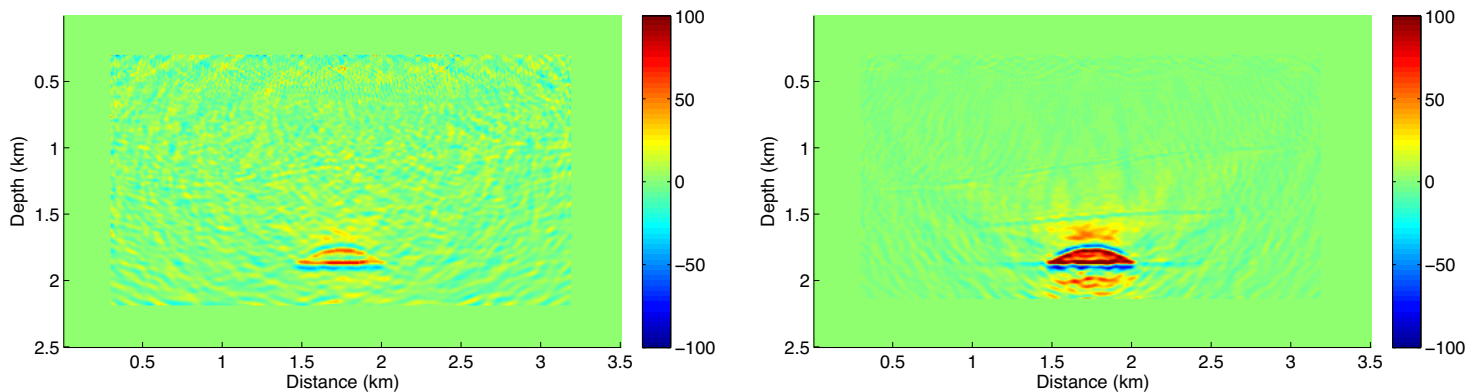

These figures show the change in wave velocity (in meters/second) between the pre-injection and post-injection models on page 10. The left-hand image was generated by conventional industry methods, the right-hand one by the new technique being tested and refined by the MIT team. The new technique produces a clearer, more-detailed image of the region in and near the CO₂ reservoir, and it greatly reduces the scattered velocity changes elsewhere.

Likewise, they know that the small-scale structures remain unchanged and that they need not be resolved “accurately” because the focus is on the reservoir. So when interpreting the time-lapse data, they impose the same small-scale structure that was obtained from the baseline data in regions away from the reservoir. “So we’re not looking at different models for the outside-the-reservoir region,” says Malcolm. “We’re only looking at different models for the inside-the-reservoir region because that’s where the changes we’re interested in are located.”

The researchers have begun field tests of their double-difference technique. Already they have applied it to seismic data collected before and after injection of CO₂ into a reservoir in an oil field in Texas located several thousand meters underground. Initial results show that the double-difference approach produced cleaner images of the CO₂ reservoir than conventional methods of analysis did—and with far less data processing. And in related work, the MIT team is developing a novel system that can detect when CO₂ may be leaking from a reservoir and raise an alarm that further study should be undertaken. Together, their techniques to verify the location of injected CO₂

and to ensure that it remains safely underground will help support the adoption of subsurface CO₂ sequestration as an industrially viable process for mitigating climate change.

• • •

By Nancy W. Stauffer, MITEI

This research was supported by a seed grant from the MIT Energy Initiative and by the National Energy Technology Laboratory of the US Department of Energy through a subcontract from Los Alamos National Laboratory. Further information can be found in:

D. Yang, M. Fehler, A. Malcolm, and L. Huang. “Carbon sequestration monitoring with acoustic double-difference waveform inversion: A case study on SACROC walkaway VSP data.” *Proceedings, Society of Exploration Geophysicists 2011 annual meeting, San Antonio, Texas*, pp. 4273–4277.

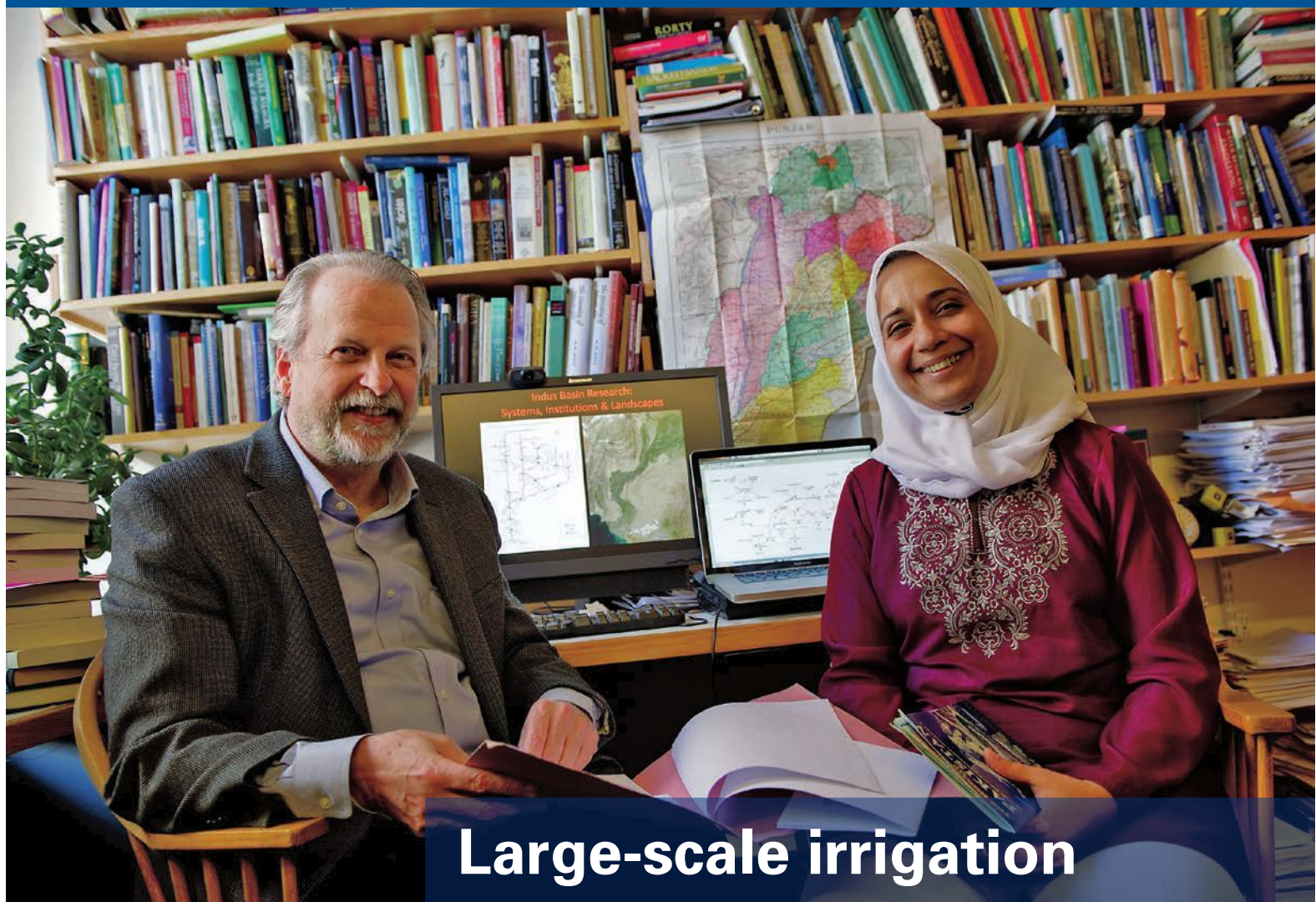

Large-scale irrigation

Understanding energy-water-food connections

James Wescoat of architecture and Afreen Siddiqi of engineering systems have been examining and clarifying the growing interconnections among energy, water, and food, with a special focus on the Indus Basin in Pakistan, where all three resources are in short supply.

This research was supported by a seed grant from the MIT Energy Initiative.

Photo: Stuart Darsch

An MIT team is providing new understanding of the growing interconnections among three critical resources: energy, water, and food. The work focuses on Pakistan's Indus Basin, where irrigation water is increasingly pumped from underground, a practice that is intensifying a preexisting shortage of energy. Using new and existing data plus statistical models, the researchers are clarifying how much pumping is going on, how it's affecting energy use and food productivity, and where and why it's happening in this region—home of the world's largest contiguous network of river-fed irrigation canals. A dynamic model under development will enable decision makers to assess the long-term, interacting impacts on energy, water, and food of proposed infrastructure and policy initiatives, taking into account the possible long-term impacts of climate change on water management.

Many researchers are examining the use of water in energy-related activities such as running power plants and extracting hydrocarbons. But less attention has focused on the growing consumption of energy to provide irrigation water for food production. Today, about 70% of all fresh water consumed worldwide is used for agriculture, and the use of irrigation continues to spread, pushing up crop yields from each hectare of land. But in recent decades, farmers in regions such as South Asia have begun pumping up groundwater rather than relying solely on water diverted from rivers and lakes. In some places, that practice is causing the water table to drop—a trend that is arousing much concern. Pumping also consumes energy, a commodity in short supply in some of the great food-producing regions of the world.

For the past two years, James Wescoat, Aga Khan Professor of Architecture, and Afreen Siddiqi, a research scientist in MIT's Engineering Systems Division, have been examining the connections among energy, water, and food. Their work focuses on the Indus Basin in Pakistan, a region where those connections are acute and all three resources are in short supply. This arid region depends critically on the Indus River, which delivers water from snowmelt in the high Hindu Kush-Karakoram-Himalayan mountains and Tibetan Plateau to the plains of India and Pakistan. In Pakistan, a complex network of canals—built by the British starting in the mid-19th century and expanded in the 1960s and 1970s—spreads water from the Indus and its tributaries over some 44 million acres of farmland.

Despite access to this enormous irrigation system, farmers in the Indus Basin are increasingly using “tube-wells” to get the water they need. They



Photo: James Wescoat, MIT

Irrigated fields in the Sheikhupura District of the Punjab Province, Pakistan.

bore stainless steel pipes into the underground aquifer and withdraw water using diesel- or electric-powered pumps. This trend, coupled with a broader shortfall in energy in Pakistan, has now turned into an acute problem. “So irrigation is not just about water; it’s not just about agriculture. It’s become intimately connected with energy and therefore greenhouse gas emissions as well,” says Siddiqi.

Much is known about water resources and agricultural development in the Indus Basin. Half a century of intensive study has yielded extensive data and a succession of water-resources models—some more sophisticated than many used in US river basin planning, according to Wescoat. But the energy component has received relatively little attention—a gap that Wescoat and Siddiqi are working to fill.

Their efforts could have significant real-world impacts. Planning is now under way in the Indus for multibillion-dollar projects for canal upgrades,

novel irrigation systems, and new reservoirs and hydropower plants. In addition, institutions are in flux, with restructuring and reorganization already taking place. It’s critical that decision makers examine the impacts of such changes on all three factors—energy, water, and food—to avoid unintended consequences that could result from giving short shrift to any one factor or to their interactions.

Understanding the status quo

To address the energy-water-food “nexus,” Wescoat and Siddiqi have been collecting, compiling, and analyzing data and formulating initial quantitative models that are helping them understand what’s going on and why. Their first task was to establish the extent of the pumping system in the Punjab Province, which makes up a significant part of the Indus Basin. The top figure on page 14 shows a sustained, almost exponential growth in tubewell use over more than three decades. Between 1987 and 2007, for

Expansion of pumped irrigation

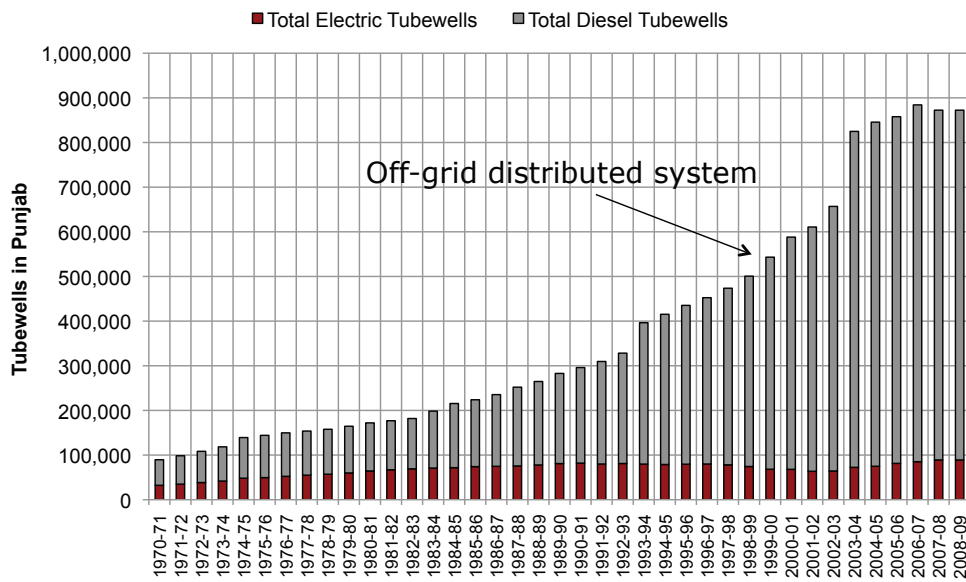

The use of pumps to supply irrigation water in the Punjab region of Pakistan has steadily increased for more than three decades. This chart shows the number of installed tubewells each year, separated by their power source. While the number of electric-powered systems has grown only slightly, use of diesel-powered systems has climbed dramatically. In the past few years, the number of tubewells has leveled off, implying a slowdown in the installation of new systems.

example, the total number of installed wells went from about 230,000 to almost 900,000. That surge was followed by a slight slowdown in recent years. Most of the growth has been in diesel-powered pumps. The number of wells with electric-powered pumps has increased only slightly.

The maps to the left, below, show the geographical distribution of tubewells in the Punjab in 1995 and in 2010, with each dot equal to 500 tubewells. The maps, generated with assistance from Emma Broderick '14 of chemical engineering, demonstrate not only the increase in installations over 15 years but also the variation in density in different parts of the Punjab.

Distribution of tubewells in Punjab Province

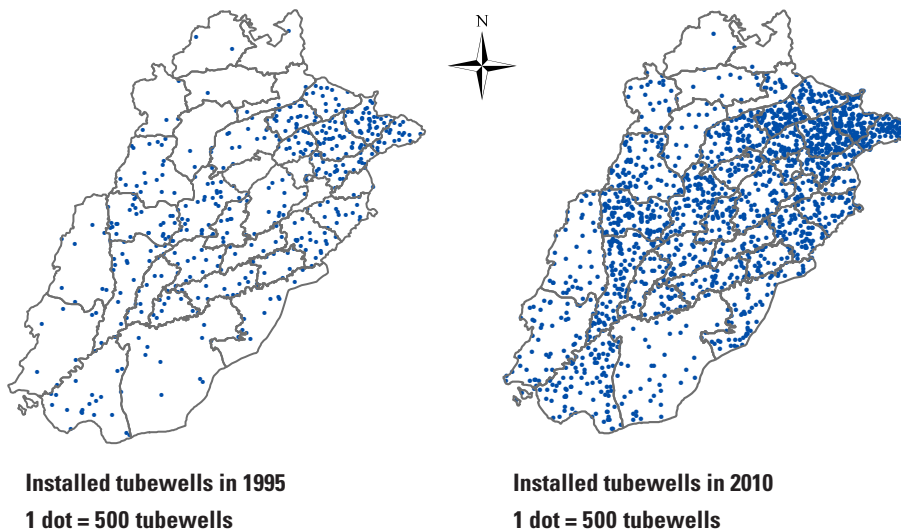

These maps show installed tubewells in the Punjab in 1995 (left) and 2010 (right). Each dot equals 500 tubewells. Comparison of the maps shows the rapid expansion of tubewell installations over the 15-year period. The individual maps show the complex variability in the distribution of tubewell pumping throughout the province.

As the use of tubewells has been expanding, deliveries from the surface canals have been declining. Over the past several decades, the supply of canal water in winter—the season when the important wheat crop is sown—has dropped on average by 0.5 billion cubic meters each year. Today, one contributor to reduced flow is delivery losses: Some 40%–60% of water in the canals simply seeps into the ground.

To illustrate those trends, the chart on page 15 shows amounts of water supplied by the canal system and by tubewells for the irrigation of wheat, a major crop in the Indus Basin and a staple food for the region. Over the last two decades, the total amount of irrigated land devoted to wheat—shown by the yellow curve—has steadily increased. The blue curve shows the amount of water coming via the surface canals, the red curve the amount pumped out of tubewells (estimated based on the number of installed tubewells, pumping flow rate, and average operation time). The decrease in surface water supplies and the

Bridging the supply gap with pumped water

simultaneous increase in the use of pumped water are striking.

Those trends suggest that the pumped supply is making up for the missing surface water—and in fact it is. The surface system is increasingly serving as a distribution system for recharging groundwater in the region. In effect, the aquifer is becoming a huge underground storage system for the Indus water—and it must be accessed using pumps. “So the pumping system is serving as a bridge to make up for supplies that were traditionally provided by the gravity-fed canal network,” says Siddiqi.

More pumping: Benefits and challenges

The growing dependence on tubewells is providing several benefits, notes Siddiqi. One is that farmers can get water whenever they want to. Farmers who rely on canal deliveries must wait for a controlled release of water into their section of the irrigation network. In contrast, farmers with tubewells can withdraw water whenever they want to and at the quantities they need (depending on local availability). That benefit is significant, given the shrinking canal deliveries.

But a far greater advantage is that the availability of tubewells ensures continued irrigation, and more irrigation means more food production. The figure on page 16, compiled with assistance from Lina Kara’In ’15 of architecture, quantifies that effect for wheat in the Indus. The gray curve tracks the expanding production of wheat from irrigated land—from just under 8 million tonnes in 1986 to almost 18 million tonnes in 2009. The other two curves show yield, that is, the amount of wheat produced per hectare

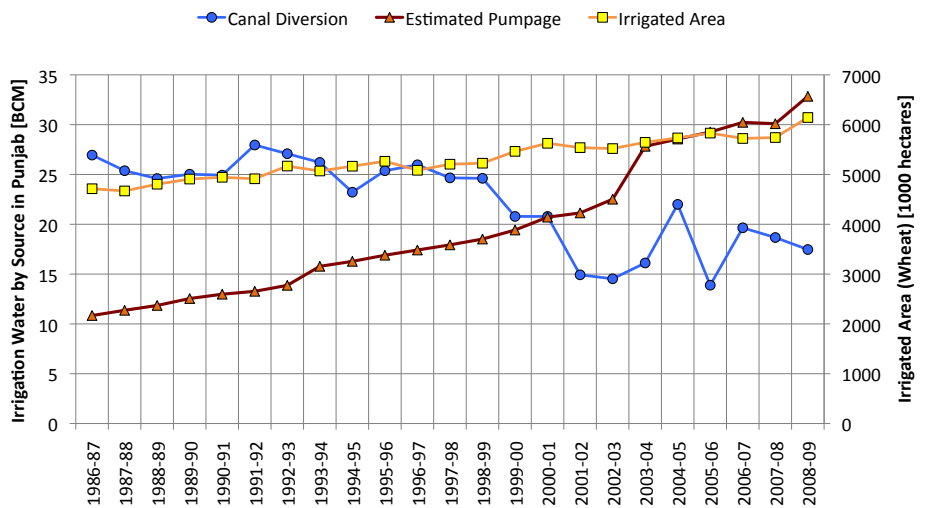

This chart shows sources of irrigation water for growing wheat in the Punjab. Supplies of water pumped up from tubewells (red curve) have been steadily increasing, while deliveries from the irrigation canals (blue curve) have been in decline. Taken together, those trends suggest that the pumped water is making up for shortages in the canal supplies. It appears that more and more canal water is leaking into the groundwater aquifer and then must be pumped to the surface. Meanwhile, the irrigated land devoted to growing wheat (yellow curve) continues to expand.

of cultivated land. The yield in areas dependent on rainfall—the green curve—shows annual oscillations as precipitation varies, but over time it remains roughly constant. In contrast, yield from irrigated land—the red curve—shows a distinctly upward trend, with a 75% increase between 1987 and 2010.

While pumping is helping to push up food productivity, it is also causing energy-related problems. For farmers using diesel-powered pumps, the cost of fuel has become a burden. The price of light diesel oil in Pakistan has been rising almost nonstop since 2001, and in just the last three years it has gone from 60 rupees/liter to over 90 rupees/liter (1 US dollar = 95 rupees). That price—along with increases in taxes on petroleum products—may explain the recent slowdown in the installation of new tubewells. “Those are very significant costs that have begun to materialize in food production—and they didn’t exist a few decades ago, when the gravity-fed canal system was providing the bulk of the water,” says Siddiqi.

From the national perspective, tubewell pumping is also straining the electric power grid. Although diesel-driven pumps predominate, some areas do have many electric-powered pumps, and in places, their electricity consumption is high enough to rival industrial use. Indeed, some factories as well as farms have had to shut down because of power shortages. While there is no control of privately owned diesel-powered systems, here the national power grid has influence because it can decide how much electricity it makes available to customers. But grid operators must make a difficult choice: How do we allocate our power among agriculture, industry, and cities?

Co-planning resources

The tight links between energy and water in agriculture underscore the importance of co-planning and co-managing these critical resources—a goal that is easy to comprehend but hard to achieve. For one thing, energy and water are often regulated

Punjab wheat production and yield

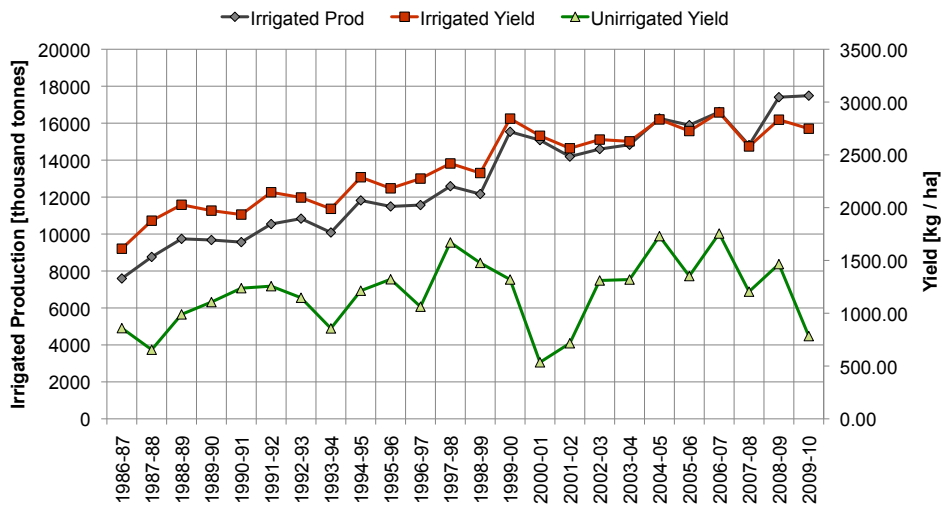

These curves show the importance of irrigation in wheat production in the Punjab. In just over two decades, the total production of wheat from irrigated land (gray curve) has more than doubled. Over the same period, the yield—the amount of wheat produced from each irrigated hectare (red curve)—has increased significantly. In contrast, annual yields from areas fed by rainfall (green curve) are considerably lower, vary dramatically from year to year, and on average are less than half of irrigated yield.

by separate entities that make independent decisions. But even with appropriate institutional reform, policy-makers, planners, and operators need help understanding and quantifying the integrated energy, water, and food implications of planning and policy options.

To that end, Wescoat and Siddiqi are developing a model based on system dynamics, a technique used to simulate the behavior of complex systems as they evolve over time. The framework of their model includes quantitative descriptions of dozens of elements in the energy-water-food system as well as interactions among them. Key variables include cultivated area, crop production, irrigation requirement, and energy demand for pumping. Values for those variables are determined by interactions among an array of factors such as technical details of the pumps, depth of the local water table, water needs of specific crops, fertilizer use, and more. Given values for external factors such as population, oil price, and market prices of other commodities, the model will perform sequential calculations,

on a seasonal time scale, and thereby track quantities and flows of energy, water, agricultural products, and other elements throughout the system. Such analyses will enable planners to assess long-term food security—a critical policy issue—as it may be impacted by supplies of water and energy in the region.

A final component is the effect of climate change on future water availability—a major concern in this area. A high fraction of the Indus Basin is covered by snowfields and glaciers. If climate change causes those snow and ice resources to change—as the ice in the Arctic is doing—the long-term impacts on the melt water feeding into the Indus River could be dramatic. The model’s calculations will take into account the impacts of such uncertainties on the range of probable outcomes.

Once the model is fully implemented, Wescoat and Siddiqi will use it to examine a series of “what if” scenarios. For example, what would happen to energy and water use and food production if new sprinkler or drip irrigation

technologies are adopted? What would happen if micro-hydro or solar power systems are installed? And what would happen if changes in prices, taxes, or policies cause farmers to grow different crops—perhaps ones that require significantly more or less water? The ability to answer such questions may lead to innovative irrigation approaches in the Indus Basin and elsewhere that could create more efficient use of both energy and water, helping to ensure the future availability of those critical resources while increasing crop production and food security for people worldwide.

• • •

By Nancy W. Stauffer, MITEI

This research was supported by a seed grant from the MIT Energy Initiative. Participation by Emma Broderick '14 and Lina Kara'In '15 was supported by the MIT Undergraduate Research Opportunities Program. Further information can be found in:

A. Siddiqi and J. Wescoat. *Energy and Water Linkages for Agricultural Productivity in the Indus Basin*. Presented at the Global Water System Project international conference—Water in the Anthropocene: Challenges for Science and Governance, May 21–24, 2013, Bonn, Germany.



Building façades that move, textiles that illuminate

A pathway to flexible, resilient architecture

A row housing project designed by an international, MIT-led team is demonstrating novel concepts in energy and architecture at the Internationale Bauausstellung (International Building Exhibition, or IBA) in Hamburg, Germany. Two innovations in the “Soft House” create an active architecture responsive to environmental conditions and changing homeowner needs: A solid softwood structure sequesters carbon, and a movable textile infrastructure harvests solar energy and provides solid-state lighting. On the exterior, a responsive photovoltaic (PV) textile façade adjusts to follow the sun, creating a novel two-axis solar tracking system. Inside, movable light-emitting curtains create spatial divisions and personal microclimates. In other work, the MIT team has designed a lightweight solar canopy that can be mounted on urban rooftops, bringing renewable energy to dense urban areas.

Sheila Kennedy of the School of Architecture and Planning is creating designs that transform the way electrical energy is harvested and distributed in low-carbon architecture. Soft energy materials, soft wood construction, and digital networks come together in new designs for resilient housing that respond to environmental conditions and homeowners’ changing needs.

This research was supported in part by a planning grant from the MIT Energy Initiative. For a full list of sponsors, go to page 21.

Photo: David Sella

Most people think of infrastructure for cities and buildings as fixed, permanent, and hard. Sheila Kennedy, MIT professor of the practice of architecture and a founding principal of the architectural firm KVA MATx, has a different idea. She calls it soft architecture. Two tenets are key: design that enables interaction between physical materials and digital networks, and resilient infrastructure that can adapt to new conditions over time and use multiple sources of energy that work together and interact to create new spaces and environments.

To make this vision a reality, says Kennedy, one needs to think of energy infrastructure not as a technology that is distinct from architecture but rather as a new set of materials with which architecture can be made. Kennedy and her collaborators have developed design techniques for integrating multi-junction PVs with textiles and other flexible substrates. The infrastructure that results from these materials is lightweight, bendable, and easy to transport and install, and it can be manufactured with less than half the embodied energy use and carbon emissions of glass-based PVs.

Clean manufacturing of a flexible energy infrastructure is just the first step. As with any innovation, the creative challenge is to find the unique opportunities the new renewable materials make possible—things that centralized electrical technology cannot do. “We need to have conceptual flexibility and creativity to see where the new materials can take us,” says Kennedy. “The most interesting applications for new materials are those that work at many levels. If we can demonstrate these ideas, we can get them out into the marketplace—where they can start doing good in the



Images and diagrams courtesy of KVA MATx

Architectural rendering of the solar-harvesting rooftop canopies for the Casa Burguesa district of Porto, Portugal.

world—earlier than we might have thought.” And that is happening now.

Soft Cities: Retrofitting renewables in urban areas

Implementing renewable energy in rapidly growing cities and dense urban areas of the world poses many challenges. Streets are narrow; older buildings have limited structural capacity; installation must be simple; and renewables need to provide immediate and tangible benefits. With a planning grant from the MIT Energy Initiative, Kennedy enlisted a multidisciplinary MIT team to investigate how flexible thin-film organic PVs—as well as LED lighting—could be integrated into textile-based roof canopies for dense urban neighborhoods.

As a case study, the team used the historic Casa Burguesa district of Porto in Portugal. Built in the 17th century, this district has more than 25,000 row houses, each with a narrow, deep plan footprint, tall upper floors, and an interior stairwell that provides daylighting and ventilation. Rooftop

solar-harvesting systems with good exposure to sunlight could help to reduce environmental strain and revitalize this urban area as a model for new urban design and energy infrastructure concepts that can be applied in many different global regions.

Working closely with the Porto Faculty of Architecture (FAUP) and industrial collaborators, the MIT team designed prototypes of a rugged, easy-to-install textile PV canopy that could be mass manufactured (see image above). The design integrates the rooftop PV canopy with the vertical space of the existing stairwell, allowing the renewable technology to complement and augment the existing row house architecture.

By day, the rooftop canopy provides energy, shading, and expanded rooftop living space; at night, the lightweight solar textiles are retracted and rolled into the stairwell for storage. The vertical stairwell shaft is used to distribute a network of clean energy, which can be used to power solid-state lighting for the interior as well as the



The Soft House, an innovative work/live row housing project, is now demonstrating novel concepts in energy and architecture at the IBA in Hamburg, Germany. The four housing units include a responsive energy-harvesting textile façade and movable light-emitting interior curtains that enable occupants to reconfigure their domestic space, creating a flexible new model for carbon-sequestering architecture. Each unit has a terrace space, a PV canopy, and a vertical convection atrium layer that circulates air, brings daylight into the ground floor, and creates vertical views of the sky.

façades of the old Porto district. Building owners could get a rebate from the city government for illuminating the historic façades, and they could sell clean energy to charge electric motorcycles, providing sustainable connections from this dense urban district to Porto's public transportation system, the Metro.

The Soft House

Drawing on their experience, Kennedy and her colleagues at KVA MATx decided to design a new model for low-carbon urban housing from the ground up. Their concept, called the Soft House, won first prize in an invited design competition for the IBA, a prestigious exhibition of innovative architectural ideas with a history that dates back to the 1920s. The IBA award confers both a great honor and an unusual opportunity: All the winning designs are being built on Wilhelmsburg Island in the River Elbe. There, 30 hectares of new housing, work, and leisure space will be monitored,

visited, and ultimately occupied, becoming a 21st century model for sustainable living.

In the Soft House (shown above), Kennedy and a multidisciplinary group of KVA colleagues and collaborators demonstrate new relationships between domestic energy infrastructure, flexible living space, and smart furnishings in a responsive, soft architecture that meets Germany's rigorous environmental standards and passive-house energy requirements.

The Soft House uses a traditional all-wood "brettstapel" construction that relies on wood dowel joints with no glues, nails, or screws. The solid spruce wood structure is temporally "soft," as the wood sequesters carbon. (Indeed, considering the life-cycle materials-production process, using spruce absorbs about as much carbon dioxide from the atmosphere as using reinforced concrete emits.) And the wood is fully demountable for recycling at the end of the building's life. The

wood structure can be fabricated by local carpenters or small-scale manufacturers, and it is exposed as an interior finish. This approach creates a natural character within the housing units, reduces embodied material energy, and eliminates the need for loose insulation, which is environmentally damaging. A dense wooden radiant floor linked to a geothermal source distributes cooling in the summer and heating in the winter.

The solid wood structure posed a design challenge: Without the internal cavity of a stud-framed wall, there is no open "chase space" for running electrical wires. To address this problem, the design team reconsidered the location and role of domestic electrical distribution and lighting. "Conceptually, we had to unpack a century of wall conventions in architecture," says Kennedy. "We moved electrical distribution out of the wall into the room and integrated it with movable domestic curtains. And on the exterior, we developed a soft solar-harvesting façade,

Responsive energy-harvesting façade

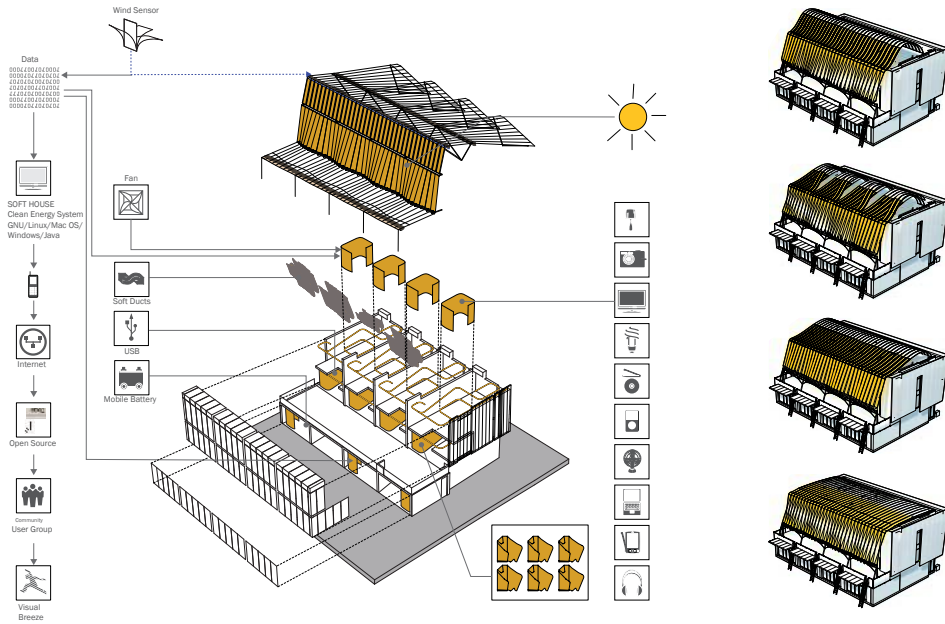

A pop-apart drawing of the Soft House, with the PV- and LED-embedded textile installations highlighted. The four housing units share an energy-harvesting façade with integrated flexible solar cells. As shown in the four small diagrams at the right, the individual strips of the façade change position to track the daily and seasonal movement of the sun. Top (winter): The façade is fully raised to capture lower winter sunlight, and many strips are twisted to let in sunshine. Second down (autumn): Some strips are raised and twisted. Third down (summer): The façade is lowered to capture the higher summer sun, and the strips are fully closed to provide shade. Bottom: The façade retracts flat against the roof during a storm.

a movable energy infrastructure that establishes the public identity of the architecture.”

Façades that move, curtains that illuminate

The Soft House responsive façade is the first architectural demonstration of soft, two-axis solar harvesting and tracking. The façade system—shown in the diagrams above—is made of textile strips integrated with a pliable, spring-like structure of fiber-reinforced composite boards that bend to optimize the seasonal solar angle of the flexible PVs. Daily east-west sun-tracking and daylight-harvesting are achieved with simple winch rotation, drawing on Hamburg’s local maritime industries. The strips twist to open views, create privacy, and provide shade in summer and indoor daylighting in winter. As the energy-harvesting, responsive façade system changes position, it creates different shade patterns that become

part of the architecture of the house. Adjustments to the responsive façade are made seasonally and daily via the Soft House Building Management System (BMS).

The Soft House responsive façade generates about 60 kilowatt-hours (kWh) of electricity daily, or about 16 kWh per housing unit—well over half the anticipated household energy needed, with the balance coming from IBA’s supplementary clean energy grid. The façade demonstrates how historically “hard” energy infrastructure—such as nonrenewable energy, glass-based solar panels, and sun-tracking machinery—can be transformed by design that uses soft, lighter-weight, low-carbon materials linked by energy and information networks.

The exterior soft façade is complemented on the interior by a set of novel smart curtains made of computer-knitted

textiles with reflective strips and LEDs that provide a movable layer of insulation and energy-efficient solid-state lighting. The tracks of the smart curtains distribute the Soft House renewable low-voltage DC electrical service for household electronics, radiant floor pumps, and LED lighting. By moving the curtains along the tracks, residents are able to enclose space to create temporary rooms for different activities, as shown in the diagrams to the right. “When you [enclose] small spaces, the reflective elements in the curtains reflect the heat from the radiant floor in winter or collect cooled air if it’s summertime, and you can create a personal microclimate,” notes Kennedy. She likens it to traditional practices of encircling beds and other furniture with textiles in order to stay warm.

The Soft House BMS manages energy generation and storage, and monitors energy consumption. A wireless DC controller provides occupants with fine control of the LED smart-lighting nodes, which can be programmed using a laptop interface. The smart curtain LED lighting system allows for real-time sensing and visualization of outside climate conditions. In “Visual Breeze,” one of several programmable software settings, exterior wind speed data are represented indoors by LED lighting that moves through the Soft House curtains, creating an ambient lighting expression of the external environment. “We bring the exterior climate inside in a playful and beautiful way, reminding us that choices we make in our domestic lives are always related to the exterior climate,” says Kennedy.

With its all-wood structure and movable soft layers, the Soft House makes the thick perimeter wall used in standard German passive-house buildings unnecessary, creating instead a flexible

Floor plan flexibility

Upper floor plan

Key

- A Living / dining
- B Kitchen
- C Play and driveway
- D Terrace and private garden
- E Smart curtain
- F Bonus room
- G Living
- H Bath / WC

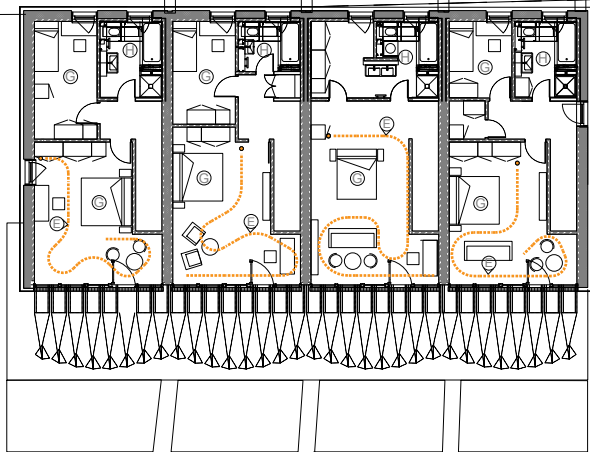

Middle floor plan

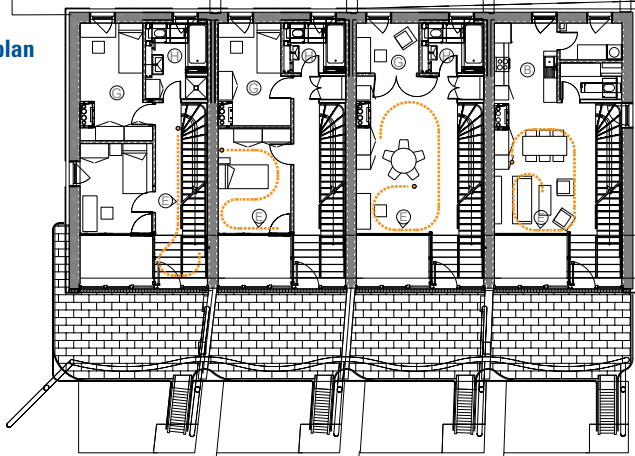

Ground floor plan

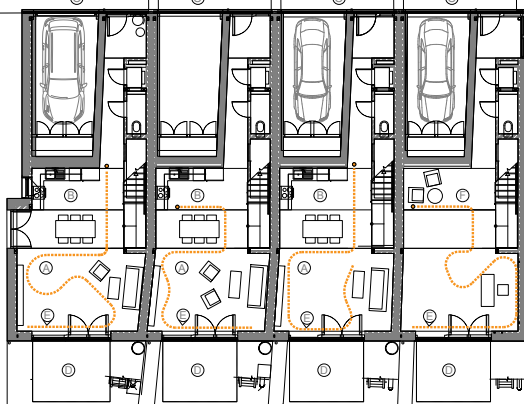

The simple, open Soft House floor plan provides flexible space for living and working. Plumbing cores are designed to let homeowners choose the number of bedrooms and the kitchen location they prefer. A separate entry off the garden level supports work/office activities on the ground floor, and the garage space can be used as a workshop area. The light-emitting curtains—represented by the yellow lines on the floor plans—can be reconfigured to create illuminated spaces with personalized climate zones to suit the needs of the homeowners.

domestic living space. And when smart curtains and tracks perform the work of the domestic infrastructure, it is easier to respond to changes in technology. “Instead of tearing down your whole house, you can simply upgrade your furnishings,” Kennedy says. “It’s a different idea about timescales in architecture, where architecture is much more permanent and the infrastructure is mobile.”

In this project, Kennedy and her team have seen the Soft House project through from design to construction, a process that brings a valuable learning experience and applied knowledge of what new flexible semiconductor materials can do. And if the real-world implementation goes as planned, the Soft House project can be replicated as a model for conditions anywhere in the world. Says Kennedy, “The real impact and excitement of the Soft House come in with the idea of what can happen with this model going forward.”

• • •

By Nancy W. Stauffer, MITEI

Research on the rooftop canopy for the urban row houses in Portugal was funded by a planning grant from the MIT Energy Initiative. Work on the Soft House was supported by the International Bauausstellung (Hamburg), KVA, and a consortium of international private- and public-sector collaborators. For more information, go to www.kvarch.net or to www.iba-hamburg.de/en/themes-projects/ and search on “Soft House.”

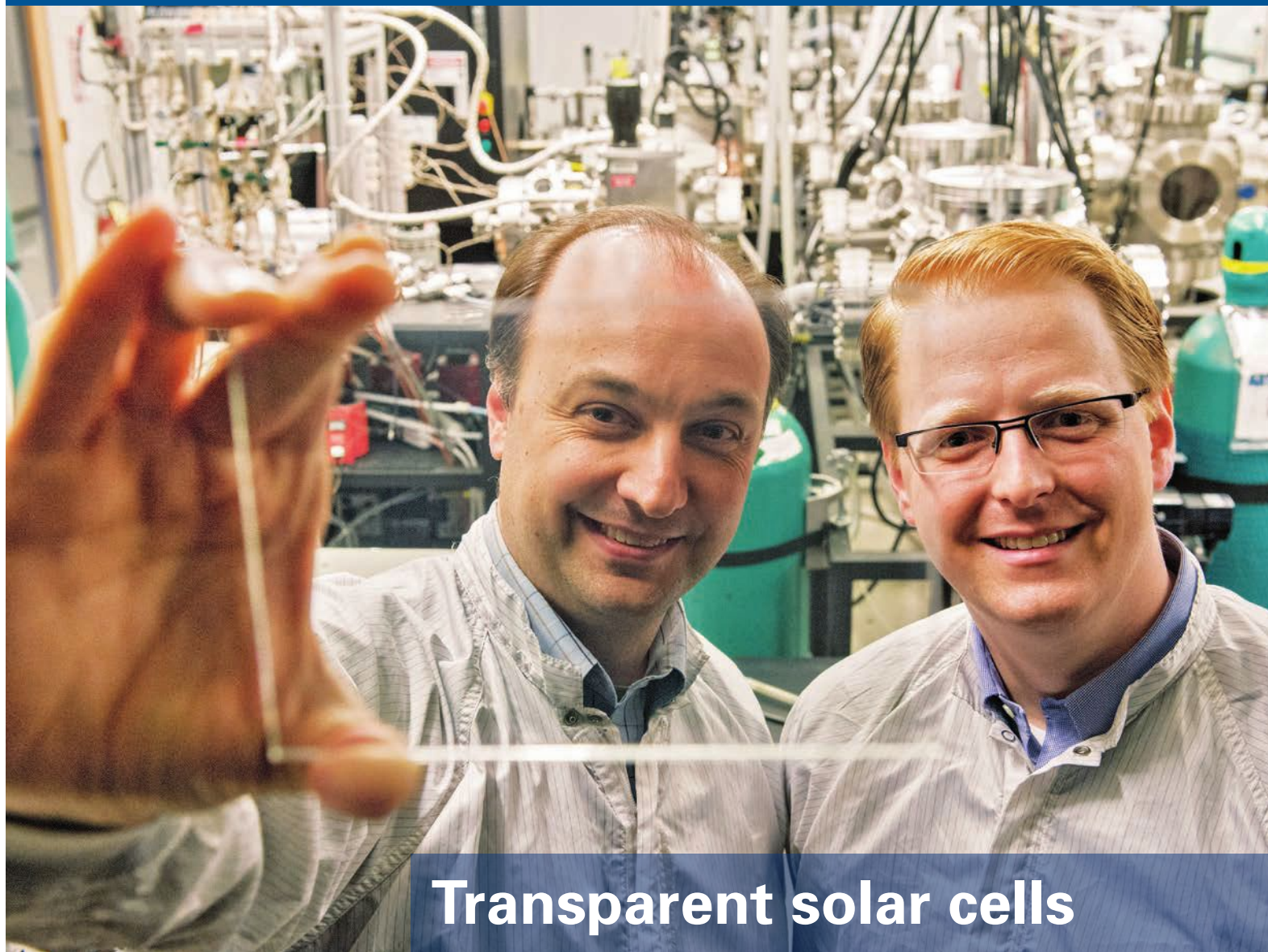

Transparent solar cells

Generating power from everyday surfaces

Vladimir Bulović of electrical engineering and computer science (left), Miles Barr PhD '12 (right), and Richard Lunt (opposite page) are making transparent solar cells that could one day be deposited on everyday objects from mobile devices to windows, turning surfaces everywhere into low-cost energy-harvesting systems.

This research was supported by the MIT Center for Excitonics, an Energy Frontier Research Center funded by the US Department of Energy.

Photo: Justin Knight

MIT researchers are making transparent solar cells that could turn everyday products such as windows and electronic devices into power generators—without altering how they look or function today. How? Their new solar cells absorb only infrared and ultraviolet light. Visible light passes through the cells unimpeded, so our eyes don't know they're there. Using simple room-temperature methods, the researchers have deposited coatings of their solar cells on various materials and have used them to run electronic displays using ambient light. They estimate that using coated windows in a skyscraper could provide more than a quarter of the building's energy needs without changing its look. They're now beginning to integrate their solar cells into consumer products, including mobile device displays.

Inventing a new solar technology that can compete commercially with today's solar cells is difficult, given existing deployment methods. But a transparent photovoltaic (PV) cell would change the rules of the game. It could be deposited on any surface without obscuring the look of the underlying material. "You can have zebra stripes or elephant footprints or whatever you want underneath because the cells that sit on top are invisible," says Vladimir Bulović, professor of electrical engineering and director of MIT's Microsystems Technology Laboratories. "They could be on everything around you—including all your windows—and you wouldn't know it."

Other research groups have previously worked on making "see-through" solar cells, usually by taking conventional opaque PV materials and either making them so thin they are translucent or "segmenting" them—a process Bulović likens to mounting pieces of a solar panel on a window with gaps for seeing out. But those approaches involve an inherent tradeoff between transparency and efficiency. "When you start with opaque PV materials, you typically have to decrease the amount of active area to increase the transparency," says Miles Barr PhD '12, president and CTO of Ubiquitous Energy, Inc. "So with existing PV technologies, it's difficult to optimize for efficiency and aesthetics at the same time."

Three years ago, a team in MIT's Organic and Nanostructured Electronics Laboratory began to tackle the problem using a different approach. Richard Lunt, then an MIT postdoc and now an assistant professor at Michigan State University, proposed making a solar cell that would absorb all the energy from the sun except the part that allows us to see. All light is made up

of electromagnetic radiation spanning a spectrum of wavelengths, each containing energy that potentially can be harvested by a solar cell. But the human eye can detect only part of that spectrum—the so-called visible light. With the right materials and design, the light that we can detect would pass through the solar cell to our eyes; the rest would be absorbed by the solar cell—and we'd never miss it.

A novel design

Inspired by Lunt's idea, the team developed a transparent PV cell. The schematic figure on page 24 shows its components and how they work together. The thickest layer (toward the left) is the glass, plastic, or other transparent substrate being coated; the multiple layers of the PV coating are toward the right. At the core of the coating are the two active layers—the absorptive semiconductor materials that get excited by sunlight and interact, creating an electric field that causes current to flow. Sandwiching those layers are electrodes that connect to the external circuit that carries the current out of the device. Since both electrodes must be transparent—not the usual reflective metal—a layer on the back of the cell can be added to reflect sunlight of selected wavelengths, sending it back for a second pass through the active layers. Finally, anti-reflective coatings can be used on both outside surfaces to reduce reflections because any light that reflects—potentially as much as 10% of the total—doesn't go through the device. "We use a combination of molecular engineering, optical design, and device optimization—a holistic approach to designing the transparent device," says Barr.

To demonstrate the operation of their solar cell, the researchers measured its



Photo: Geoffrey Supran G. MIT

Using a prototype cell, Richard Lunt demonstrates the transparency of the novel solar cell that he and his MIT colleagues have developed. A former MIT postdoctoral researcher, Lunt is now an assistant professor in the Department of Chemical Engineering and Materials Science at Michigan State University.

absorptive response and then compared it with that of a conventional solar cell. The results appear on page 25. In each case, the absorptive response (black curve) is superimposed on the solar spectrum (gray curve). In the conventional cell (top), the wavelengths at which absorption is relatively high include the visible part of the spectrum that our eyes can detect (the colored section between about 400 and 700 nanometers). In contrast, the transparent cell (bottom) absorbs well in the near-infrared and the ultraviolet parts of the spectrum—both above and below the visible range. But in the visible region, absorption drops off, approaching zero.

That critically placed gap makes the MIT solar cell transparent to the human eye—but it also means that the cell does not capture all the incident energy. "We do let the visible photons [light particles] pass through, allowing them to efficiently light the room. But we try to catch all of the photons in the infrared and ultraviolet," says Bulović. "We try not to let any of those photons get through. So a honey bee—which sees in the ultraviolet—wouldn't think it's transparent, but we humans do."

Current versions of the team's cells transmit more than 70% of the visible light, which is within the range of tinted glass now used in the windows of buildings. But their power-conversion efficiency is low—only about 2%. In a detailed theoretical analysis, Lunt, Bulović, and others showed that their design should realistically be able to reach over 12% efficiency, a rating comparable to that of existing commercial solar panels. Getting there will be a challenge, but they believe they can do it by carefully optimizing the composition and configuration of the PV materials. Indeed, says Lunt, by simply “stacking” their transparent solar cells, they could potentially reach an efficiency of 10% while still maintaining the ability to transmit light. Already they have demonstrated that an array of transparent cells integrated in series can power the liquid crystal display on a small clock, relying entirely on ambient light (see photo on page 26).

One remaining challenge is longevity. In commercial applications such as window coatings, the solar cells need to continue performing well for many decades. According to Bulović, work to extend the lifetime of related products, such as LEDs, has made good strides. With many industries tackling the same issue, he believes that this engineering problem should be solved in the coming years, and their solar cells should be guaranteed to have a commercially viable lifespan.

Costs and benefits

The cost of implementing the technology will vary with the application, solar cell efficiency, and other factors. But Barr cites several sources of potential cost savings over traditional solar systems. For instance, the processes used in fabricating the new transparent

Sample transparent photovoltaic device

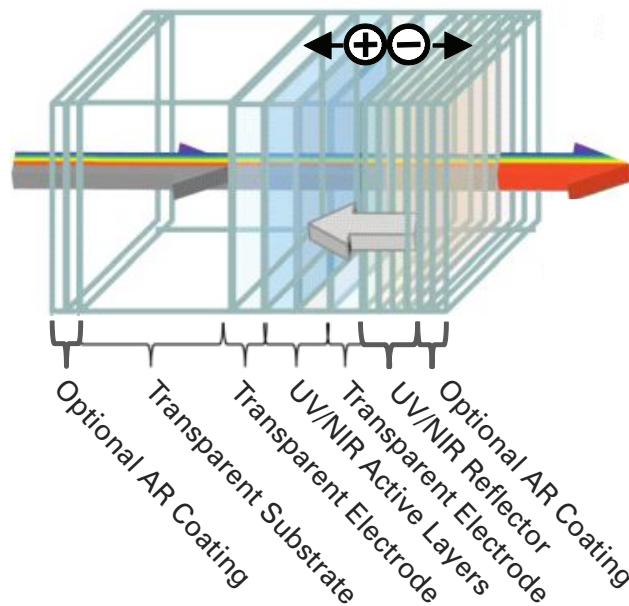

This schematic diagram shows the key components in the novel transparent photovoltaic (PV) device, which transmits visible light while capturing ultraviolet (UV) and near-infrared (NIR) light. The PV coating—the series of thin layers at the right—is deposited on the piece of glass, plastic, or other transparent substrate. At the core of the coating are the active layers, which absorb the UV and NIR light and cause current to flow via the two transparent electrodes through an external circuit. The reflector sends UV and NIR light back into the active layers, while the anti-reflective (AR) coatings on the outside surfaces maximize incoming light by reducing reflections.

PVs are environmentally friendly and not energy intensive. Indeed, the coatings are deposited at nearly room temperature, so the transparent PV can be laid down on essentially any type of surface. There's no need to use glass, which is a costly component in the fabrication of conventional systems.

Even more significant savings could come during installation—often a benefit of “piggybacking on existing infrastructure,” says Barr. To illustrate, he refers to PV-coated window glass. During new construction or a window-replacement project, the PV coating could be added for very little extra cost. The coating could easily be deposited on one of the inner surfaces of double-paned windows, along with standard

low-emittance or solar-control coatings. The PV layer would be encapsulated between the panes, well protected from weather, window washing, and other outside threats. More important, the glass, framing, and installation costs would be included in the overall cost of the construction project—the same with or without the PV coating. In contrast, when using a conventional PV system, those costs can make up half to two-thirds of the total. Distributing the energy generated by the PV-equipped windows could be as simple as placing a wire connection, power electronics, and an outlet at the side of each window or series of windows.

Spectral response of conventional and transparent PV cells

The benefits from adding the solar cells should be significant. The windows in a skyscraper, for example, provide a vast vertical area directly exposed to the bright morning and early evening sunlight. In one analysis, the research team calculated that if all those windows contained the transparent solar cells—assuming just 5% efficiency—the power generated could fulfill more than a quarter of all the electricity needs of the building. Moreover, the solar cells would block much of the infrared radiation, a large part of the sunlight that heats up a room. That effect could cut down on air conditioning needs, further reducing energy use and operating costs in the building. And all of those benefits would be gained without modifying the look of the building or obstructing views for the occupants.

Getting it into the world

Recognizing the commercial potential of this technology, Barr, Lunt, Bulović, and Bart Howe co-founded a company called Ubiquitous Energy (www.ubiquitous-energy.com), a name that reflects their vision of PVs seamlessly deployed throughout our everyday life. They are continuing development work to optimize their transparent PVs, using different semiconductor materials and device configurations that will lead to higher efficiencies and better transparencies. And they are figuring out how to integrate the PVs into consumer products that will perform their usual functions and harvest energy at the same time.

Barr expects to have their first commercial products—for mobile electronic devices—ready within a few years. Enabling such devices to gather energy from ambient light and recharge their

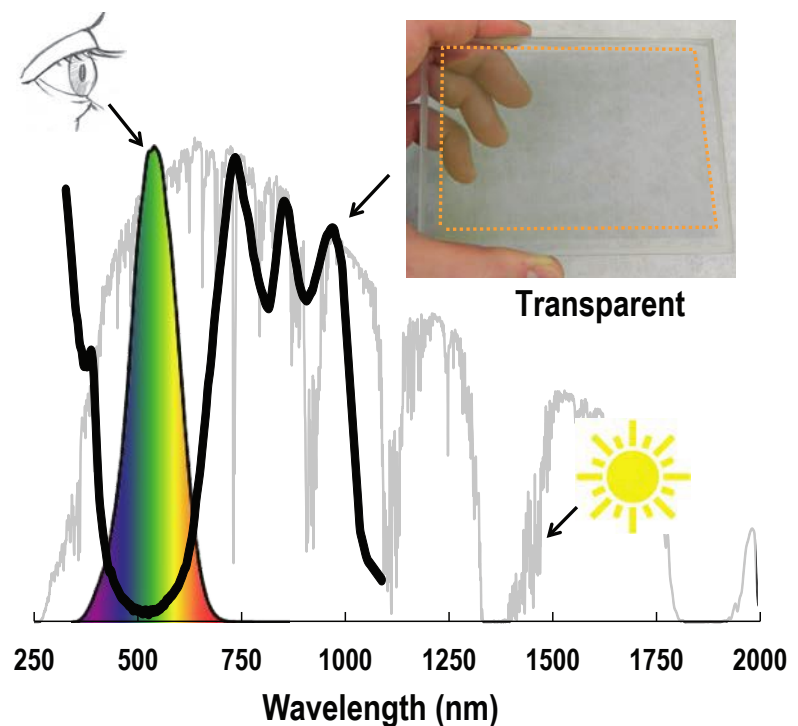
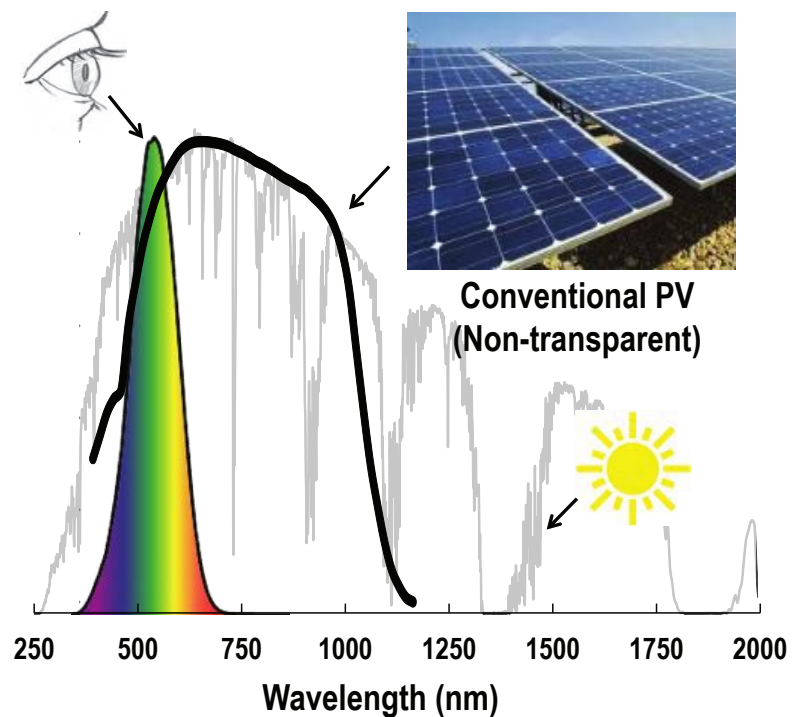

These figures present examples of the spectral responses of a conventional silicon PV device (top) and of the new transparent PV system (bottom). The responses are shown by black curves overlaid on the solar spectrum (gray curve) and the photopic response of the human eye, that is, the wavelengths that the eye can detect under well-lit conditions (colored curve). With the conventional PV, the absorbed wavelengths include most of the visible light. With the transparent PV, absorption is high in the ultraviolet and near-infrared parts of the spectrum and low where the human eye is sensitive, creating the perception of transparency.

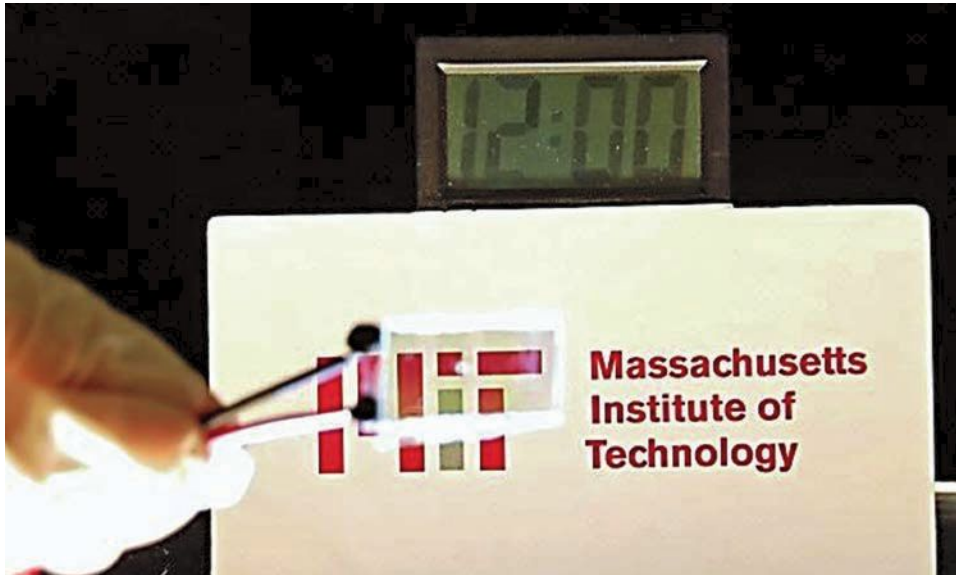

In this photo, transparent PV cells integrated in series power a small liquid crystal display (LCD) clock under ambient lighting. The red and white MIT logo is visible through the PV device.

own batteries will provide significant benefits, including added convenience, greater freedom from the power grid, and a better user experience. Perhaps more important, in the process of developing products for mobile devices, the team will learn how to make larger energy-harvesting systems so that a few years later they can scale up their techniques to the size of windows.

Bulović recognizes that their technology is not going to save the planet by providing all the emissions-free energy it needs. But he deems it an attractive part of the solution. It can be added to things that are already being deployed, and it won't require devoting vast new areas to collecting solar energy. With this technology, those areas already exist in the surfaces all around us.

• • •

By Nancy W. Stauffer, MITEI

This research was supported by the MIT Center for Excitonics, an Energy Frontier Research Center funded by the US Department of Energy. Further information can be found in:

R.R. Lunt and V. Bulović. "Transparent, near-infrared organic photovoltaic solar cells for window and energy-scavenging applications." *Applied Physics Letters*, vol. 98, no. 113305, 2011, DOI:10.1063/1.3567516.

R.R. Lunt, T.P. Osedach, P.R. Brown, J.A. Rowehl, and V. Bulović. "Practical roadmap and limits to nanostructured photovoltaics." *Advanced Materials*, vol. 23, pp. 5712–5727, 2011, DOI: 10.1002/adma.201103404.

MIT Energy Initiative announces latest seed grant awards

The MIT Energy Initiative (MITEI) has announced its latest round of seed grants to support early-stage innovative energy projects. This year's winners address a wide range of topics including thermoelectric materials, energy storage, energy-efficient algorithms, carbon dioxide (CO₂) capture and conversion, energy-harvesting devices, and petroleum reservoir management.

A total of more than \$2 million was awarded to 14 projects, each lasting up to two years. The funded projects span four of MIT's five schools and nine departments.

As in the past, the call for proposals welcomed submissions on any energy-related topic, but this time, MITEI's industry members particularly encouraged projects focusing on "big data." In response to the call, MITEI received a total of 54 proposals. The table on page 29 lists all the funded projects, some of which are highlighted in the following paragraphs.

- Much discussion is focusing on geological CO₂ sequestration for climate change mitigation and on hydraulic fracturing for shale gas production—technologies that both rely on the manipulation of fluids and pore pressure underground. One concern is whether the pressure changes involved can induce "fault slip" (see diagram on page 29) that could enhance the permeability of faults, creating leakage conduits for CO₂, methane, or brine. Ruben Juanes of civil and environmental engineering and Bradford Hager of earth, atmospheric, and planetary sciences are conducting experiments that will elucidate key physical mechanisms controlling multiphase flow during fault slip. Their work should shed new light on fundamental questions such as when a fault becomes more permeable and when it instead "heals," thereby preventing fluid flow.
- Almost 20% of current World Bank lending is allocated to transportation infrastructure projects. However, little is written about what happens to economic growth and energy demand in developing countries when their transportation facilities are improved. To clarify that interrelationship, David Donaldson of economics is developing a new methodology that draws on NASA's archives of publicly available satellite images. With China as his example, he will use new algorithms to infer economic activity and energy use from the satellite data and will track the country's major transportation infrastructure for the past four decades. Combining his economic, energy, and transportation data sets, he will perform a statistical analysis of the causal effect of transportation infrastructure.
- Recently, Erik Demaine of electrical engineering and computer science and his colleagues developed a new field of study called energy-efficient algorithms, which focuses on writing procedures for solving computational problems using minimal energy as well as minimal computer time and memory. With previous MITEI funding, they devised theoretical models that enabled them to write new algorithms that would significantly reduce the energy used in everyday tasks such as sorting and organizing data (see article on page 4). Their new work focuses on computations involved in processing big data, for example, to run network routers, perform web searches, or analyze huge scientific databases. The researchers anticipate that the promised energy savings should inspire new computer hardware designs that can take advantage of their energy-efficient algorithms.
- A standard method of locating subsurface oil and gas reservoirs involves sending sound waves deep into the earth and recording reflected signals at an array of receivers. But "inverting" the resulting seismic data to generate an image of the subsurface is challenging. Laurent Demanet of mathematics is examining a new approach to the inversion process that draws on interferometry—a mathematical technique involving the use of cross-correlations and other quadratic combinations of raw waveform data. Such data combinations show an intrinsic robustness, even in the presence of uncertainties. Applied to seismic data, interferometric inversion should give rise to sharper images of the subsurface in a variety of real-world situations.
- The full benefit of large worldwide investments in renewable energy-producing systems cannot be realized without distributed energy storage to control the interactions of these intermittent, locally available systems with the electric grid. Fikile Brushett of chemical engineering believes that flow-based electrochemical energy storage systems may offer the best combination of efficiency, cost, and scalability. He is now investigating the feasibility of an immiscible organic and aqueous liquid flow battery by examining how electrolyte composition and concentration affect the physiochemical and electrochemical properties at the liquid interface. This architecture enables high-voltage operation (greater than 2 volts), with improved energy density over present systems, and would eliminate the need for costly ion-selective membranes

and stainless steel balance-of-plant components.

- Much attention now focuses on thermoelectric devices that can generate electricity from waste heat with no combustion or moving parts. But the thermoelectric materials being considered are generally scarce, expensive to extract, and toxic. Antoine Allanore and Jeffrey Grossman of materials science and engineering are investigating the potential of a different class of materials, namely, molten salts, which are earth-abundant, affordable, and potentially highly efficient at converting heat into electricity. By combining computational and experimental studies, they will develop thermodynamic prediction tools and data that will make possible the design of a molten thermoelectric system capable of using high-temperature waste heat from sources such as incinerators, cement kilns, and steel mills.
- To limit CO₂ emissions from fossil fuel combustion, Alexie Kolpak of mechanical engineering and her colleagues are designing an effective chemical catalyst to convert CO₂ to cyclic carbonates, a class of compounds used in numerous industrial-scale applications. Their approach involves a new paradigm in “tunable” catalysts that offer the potential for controlled, real-time, reversible changes in atomic-scale surface structure and reactivity. Their new catalytic system could enable large-scale chemical sequestration of CO₂, which is currently impractical because CO₂ molecules are highly stable. Benefits include capturing CO₂ directly from the emissions source, lowering the barrier for on-site conversion into cyclic carbonates, and producing

an economically valuable product to offset the cost of implementing the new technology.

- Existing methods to assess the benefits of regulating pollutants for air quality goals often rely on simplified representations of atmospheric chemical processes. Use of these simplified analyses in crafting regulations can overestimate the outcomes achieved, for example, by not recognizing that tightening emissions controls may have declining impacts on pollutant formation due to interactions among different chemicals. Noelle Selin of engineering systems, Susan Solomon of earth, atmospheric, and planetary sciences, and John Reilly of the Joint Program on the Science and Policy of Global Change are developing, testing, and applying a new generation of tools that account for these chemical interactions and improve the accuracy of cost-benefit analyses for air pollution policies.

Funding for the new grants comes chiefly from MITEI’s Founding and Sustaining Members, supplemented by funds from John M. Bradley ’47, SM ’49 and an anonymous donor, and gifts from other generous alumni. Alumni contributions help expand the scope of the Energy Research Seed Fund Program and enable participation of faculty from across the Institute.

To date, the seed fund program has supported 117 early-stage research proposals, with total funding of more than \$14 million.

• • •

By Karen L. Gibson and
Nancy W. Stauffer, MITEI

Best poster awards

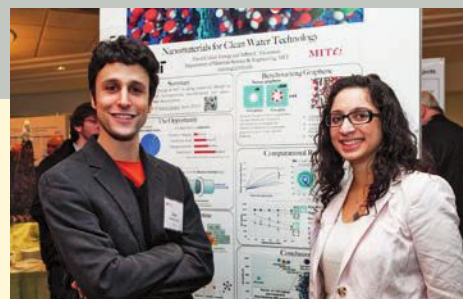

Photo: Justin Knight

At a special poster session, graduate student David Cohen-Tanugi of materials science and engineering (left) received first prize in the competition for best poster. Above, Cohen-Tanugi poses in front of his poster with research team member Shreya Dave, a graduate student in mechanical engineering.

In conjunction with this year’s seed grant review meeting, MITEI organized a day of oral and poster presentations on completed or nearly completed seed grant research projects.

At a special session, graduate students and postdoctoral researchers presented 17 posters describing research projects funded by MITEI seed grants. Three awards were given for best poster.

David Cohen-Tanugi, Materials Science and Engineering: “Nanomaterials for Clean Water Technology”

Michael Stephen Boutilier, Mechanical Engineering: “Graphene Membranes for Energy Efficient, Highly Selective Gas Separation”

Mohammad Imani Nejad, Laboratory for Manufacturing and Productivity: “Hysteresis Self-bearing Motor”

Awards were given for especially noteworthy poster presentations, judged on the basis of content and quality of presentation. The poster session and awards are held twice a year in conjunction with special events for the MITEI members that sponsor the Energy Research Seed Fund Program.

Recipients of MITEI seed grants, spring 2013

Earth abundant molten thermoelectric materials

Antoine Allanore

Jeffrey C. Grossman

Materials Science and Engineering

An immiscible organic/aqueous liquid flow battery for stationary energy storage

Fikile R. Brushett

Chemical Engineering

Energy-efficient algorithms for big data

Erik Demaine

Martin Demaine

Electrical Engineering and

Computer Science

Interferometric waveform inversion

Laurent Demanet

Mathematics

How large is the impact of transportation infrastructure on economic growth and the demand for energy? A new perspective from China, as seen from outer space, 1972–2011

David Donaldson

Economics

Hybrid energy harvesting devices

Silvija Gradečak

Materials Science and Engineering

Enhanced pseudo-capacitors for energy storage and water treatment

T. Alan Hatton

Gregory C. Rutledge

Chemical Engineering

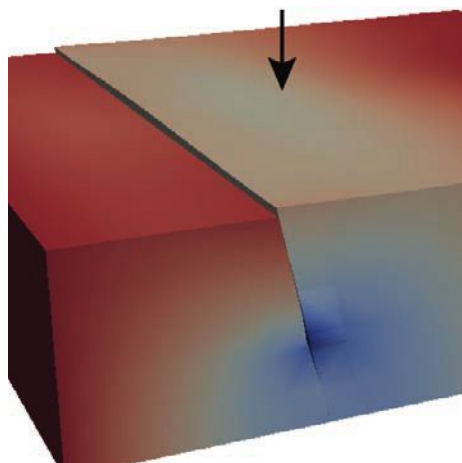

This graphic shows ground deformation and fault slip created by fluid injection underground, as predicted by a coupled flow-geomechanics simulation. Colors denote horizontal displacements in the direction perpendicular to the fault. Ruben Juanes and Bradford Hager aim to elucidate the potential for fluid leakage along such faults (see page 27).

Quantifying leakage risks in geological CO₂ sequestration and shale-gas production

Ruben Juanes

Civil and Environmental Engineering

Bradford Hager

Earth, Atmospheric, and

Planetary Sciences

Dynamically tunable catalysts for CO₂ capture and conversion to cyclic carbonates

Alexie Kolpak

Mechanical Engineering

MACE-Meter: Multi-utility access consumption evaluation meter

Steven B. Leeb

Electrical Engineering and

Computer Science

Acetic acid from methane: Coupling methane oxidation and carbonylation on Cu-exchanged zeolites

Yuriy Roman

Chemical Engineering

Improving methods to assess multipollutant regulatory outcomes

Noelle Selin

Engineering Systems Division

Susan Solomon

Earth, Atmospheric, and

Planetary Sciences

John Reilly

Management

Advanced thermal storage with water stable MOFs for building climate control

Evelyn Wang

Mechanical Engineering

Optimum decision-making in reservoir management using reduced-order models

John R. Williams

Civil and Environmental Engineering

Novel slippery surfaces: Improving steam turbines and ketchup bottles

MIT research that promises to keep ice off of airplane wings and make steam turbines and desalination plants more efficient is now moving into another challenging part of our lives: getting that last bit of ketchup out of the bottle.

In the past year, “LiquiGlide”—a nontoxic, super-slippy coating for the inside of condiment bottles—has garnered national media attention. Thousands of fascinated consumers have watched and re-watched videos in which ketchup slides swiftly out of a gently tilted LiquiGlide bottle.

But this technology will do more than just ease the lives of frustrated, bottle-pounding consumers, says Kripa Varanasi, the Doherty Professor of Ocean Utilization, who invented the coating with five members of his lab. According to their calculations, keeping exasperated consumers from throwing out that last bit will save about a million tons of wasted condiments each year. Manufacturers will be able to do away with the big plastic caps they now use on upside-down bottles, saving about 25,000 tons of petroleum-based plastics annually. And the coating will help protect public health because—unlike some nonstick coatings—this one is made completely of flavor-free food materials. “You can eat the coating, and you’re fine,” says Varanasi.

Varanasi and his team didn’t set out to help the food industry. With seed funding from the MIT Energy Initiative, they’ve been designing water-repellent coatings to improve the efficiency and durability of steam turbines—critical components in the generation of 86% of all global power. Other targets include “non-wetting” coatings to increase the freshwater output of desalination plants, to prevent the formation of ice on airplanes and power lines, and to



Images courtesy of LiquiGlide Inc.

Images captured from videos of ketchup being poured from a traditional bottle (left) and from a bottle coated inside with LiquiGlide (right). In addition to easing the lives of ketchup users, the new bottle could save tons of wasted condiments now thrown out by frustrated consumers.

keep methane hydrates from building up and clogging flows in deep-sea oil and gas pipelines.

One approach to making a surface non-wetting is to give it nanoscale roughness and then coat it with a low-surface-energy material, usually a polymer. Air pockets are trapped between the bumps, serving to reduce the contact of the liquid with the surface so it flows off more easily.

But there’s a problem. “Anything you’re trying to repel can actually impale into those features,” says Varanasi. Tiny droplets of the liquid being repelled can replace the pockets of air between the bumps, and the surface quickly goes from non-wetting to highly wetting. With “ice-phobic” coatings, frost can form before ice does, filling up the textured surface and actually accelerating the subsequent buildup of ice—a phenomenon that Varanasi has demonstrated and says could affect airplanes in flight as well as on the ground.

To prevent that behavior, he and his team fill the spaces between the surface textures not with air but with a liquid lubricant that won’t mix with the material being repelled. The bumps on their textured surfaces are posts just a millionth of a meter across—so small that the lubricant in the spaces between them is held firmly in place by capillary action. The resulting structure is durable, resistant to aerodynamic assault, and unfazed in a vacuum. It’s also easy to manufacture. Just dunk the textured material into the liquid lubricant and pull it out, and a thin lubricant layer is left behind in the spaces. Any inconsistencies in the layer—during manufacturing or afterward—“self-heals by capillary wicking,” says Varanasi.

“So you get this highly slippery surface,” he explains. “You can think about it as a coating that’s as slippery as a liquid—like if you pour something on an oil slick—but it’s also as rigid as a solid. So it’s a new paradigm for thinking

about coatings.” The new coatings can be applied to materials ranging from glass and plastics to metals and ceramics. Because the MIT team understands the fundamental processes involved, they are able to select materials and surface textures that control how fast deposited droplets slide away. And by adding the lubricant to a textured surface, they can get condensed water droplets to move 10,000 times faster than they do on the same textured surface without the lubricant. Varanasi calls the velocities “just crazy.”

Those experiments involved model surface textures to systematically study the phenomenon, but the technique works with any textured surface. “The beauty of this approach is that you can rely on random textures if they are at the right length scale,” says Varanasi. “It’s pretty forgiving of the type of texture.”

The researchers are continuing to refine and adapt their coatings for different applications. But LiquiGlide has already proved itself a winner. In spring 2012, it was named runner-up in MIT’s \$100K Entrepreneurship Competition, and it won that competition’s Audience Choice Award, with a prize of \$2,000. In fall 2012, it won the top MassChallenge award, including \$100,000. *TIME* magazine named it one of the best inventions of 2012, and *Forbes* included it among the best food innovations of the year. And the list goes on.

The LiquiGlide team is led by Varanasi SM ’02, PhD ’04 and includes J. David Smith, former MIT graduate student; current graduate students Christopher J. Love ’09 (BP-MIT Energy Fellow, 2009–10), Adam Paxson ’09 (Bosch-MIT Energy Fellow, 2009–10), and Brian Solomon (Shell-MIT Energy

Fellow, 2012–13); and former MIT postdoctoral associate Rajeev Dhiman.

In August 2012, Varanasi and Smith formed LiquiGlide Inc., a startup company located in Cambridge, Massachusetts. They expect to have commercially available coatings in the next year or two.

Go to www.liqui-glide.com/applications/ to watch videos of ketchup, mayonnaise, jelly, and even hair gel sliding smoothly out of bottles, without a trace left behind.

• • •

By Nancy W. Stauffer, MITEI

For more information about the technology, see the following publications:

S. Anand, A.T. Paxson, J.D. Smith, R. Dhiman, and K.K. Varanasi. “Enhanced condensation on lubricant-encapsulated surfaces.” *ACS Nano*, vol. 6, no. 11, pp. 10122–10129, 2012.

K. Rykaczewski, S. Anand, S. B. Subramanyam, and K.K. Varanasi. “Mechanism of frost formation on lubricant-impregnated surfaces.” *Langmuir*, vol. 29, pp. 5230–5238, 2013.

J.D. Smith, R. Dhiman, S. Anand, E. Reza-Garduno, R.E. Cohen, G.H. McKinley, and K.K. Varanasi. “Droplet mobility on lubricant-impregnated surfaces.” *Soft Matter*, vol. 9, no. 6, pp. 1723–2086, 2013.

The novel non-wetting technology

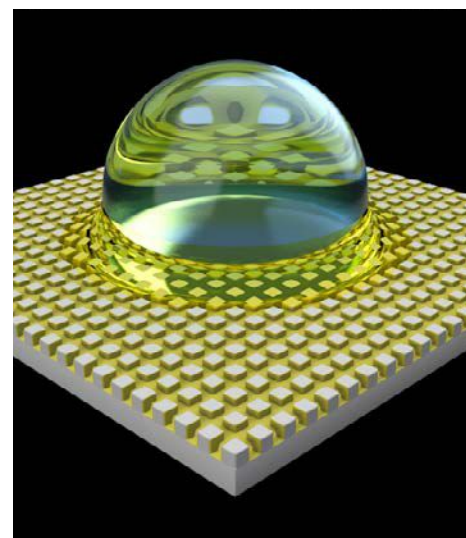
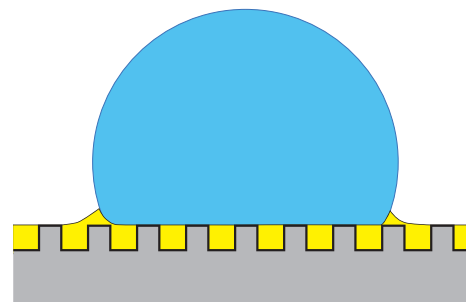

To make their super-slippery coating, the researchers create a textured surface and fill the spaces between the posts with a liquid lubricant. Because the posts are just a millionth of a meter across, the lubricant is held in place by capillary action. The selected lubricant does not mix with the material being repelled, so when a droplet lands, it essentially floats along the lubricant, moving across the surface at an unprecedented speed.

Yang Shao-Horn: Catalyzing the next generation of batteries

MIT Professor Yang Shao-Horn admits that as a girl she wasn't a very good student—at least according to traditional standards. Born and raised in Beijing, where standardized exams were the common measure of academic success, Shao-Horn excelled at exploring open-ended questions. She dreamed of becoming a dancer.

Now, as the Gail E. Kendall associate professor of mechanical engineering and associate professor of materials science and engineering at MIT, Shao-Horn works at the cutting edge of basic energy science research, endeavoring to uncover the secret forces at work inside batteries and fuel cells—research that holds promise for a wide range of energy-related applications, from electric cars to solar power.

Already, she has made several key discoveries. In 2008, she was part of a team that took the first atomic-scale compositional images of fuel-cell nanoparticles. In 2011, she established a design principle that governs oxygen electrocatalysis on oxides and identified a new catalyst capable of speeding up water oxidation—the reaction central to advanced energy-storage systems—by a factor of 10. And in 2012, Shao-Horn's lab used X-ray photoelectron spectroscopy to reveal new details of the complex reactions taking place within advanced lithium-air batteries.

Shao-Horn has won numerous honors for her work in electrochemical and photoelectrochemical energy storage and conversion, including the Charles W. Tobias Young Investigator Award (2008), the Tajima Prize of the International Society of Electrochemistry (2008), and the International Battery Association Research Award (2013). But energy research was not what Shao-Horn set out to do when she first

headed off to Beijing University of Technology. Her goal was to become a metallurgist like her father.

It was at graduate school at Michigan Technological University that she made the surprising decision to study lithium-ion battery materials, which were just then hitting the market. This research topic was not known in materials science and engineering at that time. "I chose a topic I knew nothing about," she says. "I wanted to go into a completely new area and be adventurous." Using transmission electron microscopy, she explored how the material structure functions and influences battery capacity during charge and discharge.

Ever since, Shao-Horn has continued to venture across disciplinary boundaries. In 2002, she joined MIT's faculty in mechanical engineering—even though her degrees are in metallurgical and materials engineering. She credits her husband, Dr. Quinn Horn, with getting her to apply for the position. "I said, look, first of all I don't have a mechanical engineering degree. Second, I know nothing about fuel cells," which was the specialty requested in the posting, she recalls. But he could see that her skills were a good match and encouraged her to apply anyway. She got the job.

Initially, she admits, she found the prospect of joining the Institute "daunting." But now, she says, "I just find that MIT is really a fascinating place with many stimulating, exciting, admirable faculty."

Shao-Horn quickly became involved in multidisciplinary energy projects on campus. In particular, she served on the MIT Energy Research Council, which launched the MIT Energy Initiative in 2006. She also helped found MIT's Electric Vehicle Team in 2007, donating a 1976 Porsche for students to convert

to battery power. "It was a fantastic project with students from multiple disciplines and departments involved," she says, adding that the project helped her understand how to utilize the lithium-ion batteries she was researching in a practical application.

Today, as director of MIT's Electrochemical Energy Laboratory, she oversees the work of more than 20 graduate students and postdoctoral associates. "I find that it is the most rewarding, to work with students and see them transform from when they arrive and some don't know what they want to do in life...into confident, brilliant, and professional individuals," she says. Her PhD students have gone on to industry and to faculty positions at Cornell University, Georgia Institute of Technology, and various universities in Asia.

To ensure that MIT students are equipped with a fundamental understanding of the concepts, tools, and applications central to electrochemical science and engineering, Shao-Horn introduced a new subject in 2006, 2.625J/10.625J Electrochemical Energy Conversion and Storage. This graduate-level class has drawn students from mechanical engineering, chemical engineering, and materials science at MIT and from Harvard, Northeastern, and Tufts. "We combine the traditional concepts of electrochemistry or electrochemical techniques with chemical physics or surface chemistry, looking at how molecules react at surfaces. These traditionally separate concepts are combined in one course," she says.

"Energy storage is becoming a very popular topic," she says, explaining that it is central to the practical use of such renewable but intermittent power sources as wind and solar energy. "We store solar energy or

wind energy by splitting water into hydrogen and oxygen, and then in batteries or fuels cells we combine them and power our needs.” The difficulty is that current storage solutions lose energy due to the inefficiency of the electrochemical reactions.

To make these technologies practical, Shao-Horn investigates the fundamental nature of the chemical reaction that drives battery technology—the movement of electrons from a positively charged electrode (anode) to a negatively charged electrode (cathode) through an electrolyte. The oxidation reaction at the heart of this process strips ions from the electrolyte and binds them to the anode, freeing electrons to travel from the anode to the cathode, powering a load along the way.

Most recently, Shao-Horn has been exploring ways to improve the performance and lifespan of lithium-air batteries in an effort to develop a viable alternative to the lithium-ion batteries now used in electric vehicles. While lithium-ion batteries remain the state of the art, lithium-air batteries are lighter and more powerful, providing two to three times as much energy by weight. However, to date they have proved much less efficient. Typical lithium-air batteries return just 60% of the energy used to charge them, while lithium-ion batteries are 90% to 95% efficient.

Together with her team and collaborators, Shao-Horn has already managed to develop an experimental lithium-air battery that demonstrates a round-trip efficiency of 75%—among the highest efficiencies reported. To move further forward, she continually asks fundamental questions about the process, such as: What is the physics behind the reactions that control the functionality of materials? What is the mechanism by



Photo: Stuart Darsch

Yang Shao-Horn, the Gail E. Kendall associate professor of mechanical engineering and associate professor of materials science and engineering at MIT.

which a material or series of materials exhibits high stability or low stability?

The goal of creating better energy-storage technology is ever present. “Not only do we push the boundaries of knowledge, but we’re also passionate about applying our new findings in practice to create new catalysts, new battery electrodes, and new energy-storage systems,” she says. “We’re interested in understanding how the surface, for example, reacts with lithium, reacts with oxygen, how the surface reacts with water—that could have huge fundamental implications in terms of understanding...catalytic activity for solar fuel applications or for lithium-air batteries.”

Succeeding in this work requires multidisciplinary collaboration, and Shao-Horn continually reaches out to a “bigger pool of people with multiple talents to work with,” she says. “We work with chemists and chemical engineers, physicists and mechanical engineers, and materials scientists.”

She is also involved with the Singapore-MIT Alliance for Research and Technology’s interdisciplinary research group on low-energy electronic systems as well as with the Center for Clean Water and Clean Energy at MIT and the King Fahd University of Petroleum and Minerals in Saudi Arabia. Projects for these groups include trying to change the architecture of electronics so that devices consume less energy, and helping Saudi Arabia diversify from an oil-dependent economy.

Clearly, Shao-Horn enjoys tackling new challenges. “I enjoy adventure and like to sense the unknown,” she says. “That’s why I like to work on open-ended problems.”

• • •

*By Kathryn M. O’Neill,
MITEI correspondent*

Bringing science to life: Undergrads learn by seeing, doing in 3.012

How cold can it get before my pipes burst? How long will this new battery last to power my cell phone? How warm does water need to be to heat my home?

The students who took 3.012 Fundamentals of Materials Science and Engineering learned the answers to these questions and much more during the new and improved 2012 fall semester of the thermodynamics component taught by Jeffrey C. Grossman, MIT's Carl Richard Soderberg Associate Professor of Power Engineering. Because 3.012 (broken into thermodynamics, taught by Grossman, and structure, taught by Professor Silvija Gradečak of materials science and engineering) is the first required class for undergraduates who have declared materials science and engineering as their major, Grossman wanted to make sure the students came away knowing the basics. But he also wanted to find a way to make learning more fun and memorable to get them excited about what was ahead. So, after teaching the class for three years, Grossman was ready to make it his own by changing things up a bit through what he calls "demo-driven thermo."

"The idea is that some classes, like basic physics 101, benefit tremendously from a bit of built-in intuition—like the idea of conservation of momentum, throwing a ball into a wall. A lot of what we remember are concepts that feel tangible," Grossman says. Thermodynamics, on the other hand, can sometimes be very unintuitive. "The idea was to add intuition into the class. To do that, we needed to get stuff into people's hands. The more you can touch and feel thermodynamics, the more you're going to connect to the concepts."

Having received funding from the MIT Energy Initiative through a grant from

the S.D. Bechtel, Jr. Foundation, along with support from the Department of Materials Science and Engineering (MSE), Grossman sent his former teaching assistant Kevin Gotrik, graduate student in MSE, out exploring thermodynamic demonstrations to use to enhance the class. Grossman and Gotrik spent the summer of 2012 designing, testing, and retesting demonstrations to illustrate the concepts Grossman would teach in class.

After many experiments—some successful, some unsuccessful—Grossman was ready for the first day of class. At the beginning of that class, and each class that followed, he presented a demonstration and then asked related questions. For example, in one demo, he showed the students a bottle of water that he had cooled to -10°C —but it was still liquid. He then poured it into a bowl. As he poured the water, it turned into ice. He explained that under certain conditions materials can be cooled below their solidification temperature—and the reverse, materials can be heated above their melting temperature. What makes them change from one phase—for example, liquid, solid, or gas—to another?

Grossman then went into a lecture about phase diagrams, explaining how materials change phases. After teaching his planned lesson, he applied the concepts to answer the initial question. Using the "supercooled water" example, Grossman explained that the water was in a phase it didn't want to be in: It badly wanted to be ice. Hitting the bowl was enough to nucleate the water, enabling it to change from the liquid to the solid phase.

"I think seeing all these hands-on demonstrations, seeing all the cool ways what you're learning can be

applied to things like making motors or causing chemical reactions, is a great way to get the students to connect with the lecture material," says Sam Shames '14 of MSE, who experienced the class without the experiments as a student and with them as the teaching assistant for the new-and-improved class.

"I remember from the year before—when I was taking the class—which concepts we got quickly and which were more difficult," Shames said. "Having experienced that, I could see how having the demos there took some of the more difficult concepts and made them more concrete."

Beth Murphy '15 of MSE, who took the class in fall 2012, agrees. "Experiments can be fun, but sometimes it's hard to see how they back what you're actually learning. But Professor Grossman did a really good job of tying them together. He brought the science to life."

Shames' favorite demo explained how when materials change phases, some of their properties—such as volume—change as well. To demonstrate this concept, Grossman took a steel pipe and held it up. He then hit it with a hammer. Nothing happened. He tried a bigger hammer. Still, nothing happened. Then he took a sledgehammer, created a huge bang, and still the pipe didn't even crack. Finally, Grossman poured water in the pipe and poured liquid nitrogen over it, freezing the water. Unlike most materials, which contract when going from a liquid to a solid, water expands. The pressure created by the freezing water caused the pipe to burst.

Shames says that all of a sudden something that seemed so abstract "is right in front of you...Something clicks and it all makes sense."



Photos: Dominick Reuter

He says this is “the coolest part” about the demos—not the shock the first time but seeing them the second time, when you understand why it is happening and “make the connection with something that was just an equation on the board.”

Achieving this “clicking moment” strikes at the heart of what Grossman’s “demo-driven thermo” is all about.

“I tell them all, go out and tell people about thermo. Use these demos and make it fun,” Grossman says. “So even in 10 years, when they’re in some spinoff changing the world or whatever, the hope is they’ll have a memory of this and be able to connect it back to the basic concepts. That’s the idea... showing students how they can use thermodynamics to answer questions that come up on the job and in day-to-day life.”

Grossman believes his enhanced class is a perfect example of why residence-based education is still really important in today’s increasingly virtual world.

“Everyone is excited about online learning, and I am too. But what we do so well at MIT—it’s kind of the slogan of the Institute—is that we couple learning with practice, experiment with theory. And I think the power of that in the classroom is tremendous.”

• • •

By Victoria Ekstrom, MITEI



Top: An eruption of foam illustrates the importance of surface tension in an exothermic (energy-releasing) reaction during a 3.012 demo called elephant toothpaste. In this reaction, hydrogen peroxide (mixed with a bit of soap) is catalyzed by potassium iodide to become water plus oxygen: $2\text{H}_2\text{O}_2 \rightarrow 2\text{H}_2\text{O} + \text{O}_2$. The small amount of H_2O_2 generates a large volume of oxygen, which is trapped by the soapy water to form a rapid outpouring of bubbles. Food coloring was added to the inside of the container to make the foam have the appearance of toothpaste (or a candy cane).

Bottom: Students don safety gloves to touch the warm foam produced by the reaction.

Energy IAP: Preparing for and adapting to climate variability

In late October, “Superstorm Sandy” hit the shores of the United States, leaving an estimated \$62 billion of damage in its wake. In New York City, 13-foot storm surges broke all records. What does increased climate variability mean for Massachusetts? How can we prepare for and adapt to the changing climate? This topic was the focus of a variety of activities during MIT’s Independent Activities Period (IAP) in January 2013. Participants attended discussions and presentations involving Massachusetts officials and MIT researchers (see main article and photos). In other sessions, they helped to weatherize a Cambridge building, found out how to use GIS-based energy maps and spatial data to locate power plants and pipelines, and toured Boston’s subway tunnels and learned what America’s oldest subway system is doing to modernize and adapt to change.

MIT researchers, Massachusetts officials highlight strategies to adapt to climate change

Just days after President Obama called for action on climate change in his second inaugural address, members of Massachusetts Gov. Deval Patrick’s administration joined energy and environment researchers at MIT to discuss strategies for adapting to climate change. The panel discussion on January 23, 2013, fostered a continued partnership between MIT and the Commonwealth to advance energy and environment innovation.

“We are so pleased to have the opportunity to utilize one of the Commonwealth’s greatest intellectual resources—MIT—to tackle this global challenge,” said Massachusetts Undersecretary for Energy Barbara Kates-Garnick, the moderator of the panel.

MIT Professors Kerry Emanuel and Michael Greenstone kicked off the event

with a discussion on the clear realities of climate change.

“When we’re talking about global climate change, no one really cares if the temperature goes up a few degrees. On a day like today it would seem to be a good thing,” said Emanuel, the Cecil and Ida Green Professor of Atmospheric Science. “What we really care about...is the side effects of that global warming.”

Side effects include increases in sea levels of as much as three feet by the end of the century, increased incidence of heat waves and drought, and more intense rain and snow storms and hurricanes.

When asked how long we have to prepare, Emanuel said the time scale is negative. But he pointed out that part of the problem is policies that encourage people to live and build in risky places.



Photos: Dominick Reuter

Government officials joined MIT faculty on January 23, 2013, for a panel discussion hosted by the MIT Energy Initiative and the Joint Program on the Science and Policy of Global Change. Left to right: Massachusetts Undersecretary for Energy Barbara Kates-Garnick, moderator; MIT Professors Kerry Emanuel and Michael Greenstone; Stephen Estes-Smargiassi of the Massachusetts Water Resources Authority; and Gregory Watson of the Massachusetts Department of Agricultural Resources.

“People are moving into hurricane-prone regions, including right here in Massachusetts,” Emanuel said. “For these people, this is bad news.”

Emanuel’s colleague Greenstone, the 3M Professor of Environmental Economics, then laid out some of the ways to confront the challenges of climate change.

Mitigation—that is, reducing greenhouse gas emissions to reduce the severity of climate change effects—is one course of action. But, Greenstone noted, a comprehensive mitigation strategy hasn’t generated much enthusiasm around the world. “I say that as someone who listened to the president’s inaugural and thought, ‘This is fantastic. The president is making a big effort on this,’” said Greenstone. “Unfortunately, I’m not sure everyone in the country agrees with the president, and the politics have proven to be a little harrowing.”

Like Obama, Greenstone believes the United States should be a leader, encouraging other countries to also confront climate change. Acting through adaptation measures can complement both mitigation initiatives and funding of basic research and development for low-carbon energy sources in the United States and abroad.

Greenstone said that in addition to contributing to the science of climate change, researchers can partner with policymakers and planners to try to find successful adaptation strategies. This collaboration is important because “the playbook of successful adaptation strategies I think is rather small,” Greenstone said.

Fortunately, Massachusetts is playing a key role in developing that playbook.



Massachusetts Undersecretary for Energy Barbara Kates-Garnick, moderator, welcomes panel members and attendees to the IAP event.

Two years ago, the Commonwealth released the Massachusetts Climate Change Adaptation Report, which lays out strategies to help prepare for and respond to the impacts of climate change. Stephen Estes-Smargiassi, director of planning for the Massachusetts Water Resources Authority (MWRA), and Gregory Watson, commissioner of the Massachusetts Department of Agricultural Resources, spoke about some of their efforts.

Estes-Smargiassi used the Deer Island treatment plant as one example of the MWRA’s work to make adaptation part of its long-term strategy.

When the department began designing the plant in the 1990s, its engineers realized that if sea level rose, the plant’s capacity would be compromised. To ensure they would have the capacity needed for the future, the MWRA decided to raise the design of the plant almost two feet. Estes-Smargiassi called this move the first significant and concrete effort at climate adaptation nationwide.

“When we’re making a renovation, we’re going to make sure climate change is a part of it. It’s built into our thinking,” Estes-Smargiassi said.

The department is also taking steps to be more efficient. Just this week, the MWRA was nationally recognized by the American Council for an Energy-Efficient Economy and the Alliance for Water Efficiency for its

exceptional efforts to save both energy and water. The MWRA’s work contributes to the Commonwealth’s overall effort to reduce emissions by 25% by 2020 and by at least 80% by 2050 below statewide 1990 emissions. Mandated by the Massachusetts Global Warming Solutions Act of 2008, these emission-reduction targets are the most ambitious in the nation.

Noting that a third of global greenhouse gas emissions comes from the food system, Watson highlighted his department’s work. Calling large commodity-based agriculture “a thing of the past,” Watson said his department is turning to new, more sustainable techniques: composting, enriching soils with nutrients, increasing fertility with biochar (charcoal substitute made from organic material), and encouraging “grow local” campaigns.

“We’re creating a sustainable agricultural economy in Massachusetts,” Watson said. And that’s “the direction agriculture in this country is headed.”

While there are substantial efforts under way in Massachusetts, Kates-Garnick concluded the discussion by highlighting the need for continued work.

“We have a piecemeal approach. One administration leaves, another comes in. And while we may all be committed...what we really have to do now is put in place long-term consistent solutions....I think we’re really focused on doing this in our administration,” Kates-Garnick said.

• • •

By Victoria Ekstrom, MITEI

IAP event showcases student research

MIT students brought their latest climate change ideas and findings to the table at an event on January 29, 2013. The multidisciplinary group of young researchers made presentations to officials from the Commonwealth's Executive Office of Energy and Environmental Affairs in hopes that the state would be able to leverage the information for future planning and implementation.

"Going forward we will need to be thinking out of the box, creatively, for future planning," Massachusetts Undersecretary for Energy Barbara Kates-Garnick said at the event. "So much of what you're doing is totally relevant to what we're working on....I'm sure that we will be back in touch."



Jennifer Morris, graduate student in engineering systems, describes the added costs that come when combining a renewable portfolio standard (RPS) and a cap-and-trade policy. Her research shows that an RPS shifts investment away from least-cost emission-reduction options and toward specific renewable technologies that could be more costly.

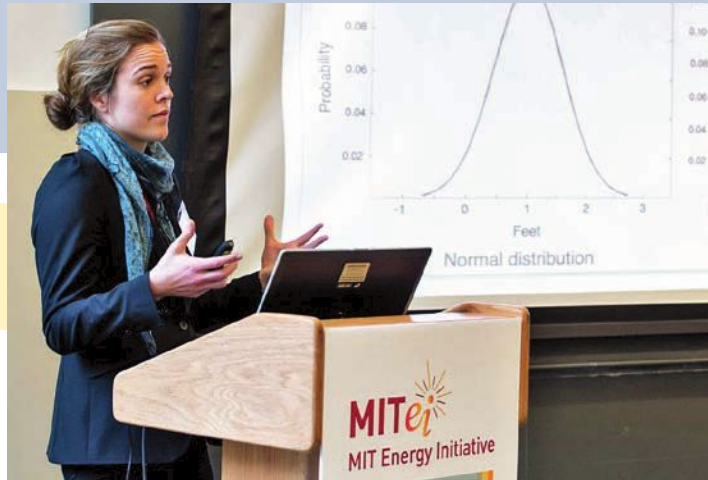

Photos: Justin Knight

Megan Lickley, research associate in the Joint Program on the Science and Policy of Global Change, discusses her work on the need to protect the coastal infrastructure under rising flood risks. She measured the costs associated with adding a sea wall to protect power plants off the coast of Galveston, Texas, as an example of how her research could be applied.



Christopher Mackey, graduate student in architecture, describes ways to counter the heat island effect by adding vegetation and reflective roofs to cool urban microclimates. His research shows the success such strategies could have, using the city of Chicago as an example.



Daniel Chavas, graduate student in earth, atmospheric, and planetary sciences, presents on the science of hurricane size, noting that larger storms (such as Sandy) can cause significantly more damage than smaller storms of comparable intensity.

Energy classes pass 1 million online visits

In 2009, the MIT Energy Initiative and MIT OpenCourseWare (OCW)—thanks to funding from the S.D. Bechtel, Jr. Foundation—set out to adapt 15 Energy Studies Minor classes for publication on MIT’s signature online platform. Three years later, that goal will soon be exceeded.

Fifteen Energy Minor classes have already been published on OCW, and two more are on track for publication by the end of the year. OCW’s current catalog of energy classes (25 in total) has logged more than a million visits since 2009. That includes just over 380,000 visits during 2012.

Free of charge, visitors on or off campus are able to access course materials such as syllabi, problem sets, tests, slides, and—in the case of five energy classes—even video.

The classes are organized in the newly minted “Energy Courses” section of the OCW website, which reflects the basic organization of the Energy Studies Minor to help users navigate the curriculum. Like the minor itself, the online classes give a landscape view of energy learning and are meant to pique the interest of a wide range of students, regardless of their discipline or focus.

“Whether students want to dip their toe in or jump all the way into the pool, there’s something for everyone,” says MIT Energy Initiative Director of Education Amanda Graham. “That means we need to make energy learning available everywhere, in a variety of formats, to maximize the impact on and off campus.”

The classes give a taste of the minor, from “Introduction to Building Technology” to “Energy Economics.”

The screenshot shows the MIT OpenCourseWare website interface. At the top, it says 'MIT OPEN COURSEWARE MASSACHUSETTS INSTITUTE OF TECHNOLOGY'. There are navigation tabs for 'Courses', 'About', 'Donate', and 'Featured Sites'. The main content area is titled 'Lecture 14: Innovation and Energy Business Models' and features a video player with a professor pointing at a chalkboard. The video player has a progress bar and 'Previous' and 'Next' buttons. Below the video, there are buttons for 'About this Video', 'Playlist', 'Lecture Slides', and 'Download this Video'. A description and instructor name (Donald Lessard) are also visible.

The most popular courses of 2012 were “Thermodynamics & Kinetics,” “Introduction to Electric Power Systems,” and “Introduction to Sustainable Energy.”

The hope is that eventually all Energy Studies Minor classes—which currently number 45—will be available online for all learners to use.

Browse energy classes at ocw.mit.edu/courses/energy-courses/.

• • •

By Victoria Ekstrom, MITEI

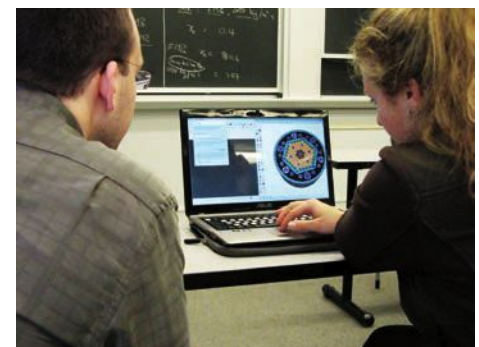

Photo: Curt Newton, MIT

Top: Screenshot from OCW class *Energy Decisions, Markets, and Policies*, featuring Professor Donald Lessard of management.

Bottom: Research Scientist Michael Short of nuclear science and engineering and student Ekaterina Paramonova '13 review her team’s design of a reactor core as part of 22.033 Nuclear Systems Design Project. Short’s fall 2011 version of this course is now published on OCW.

Energy alumni: Where are they now?

Photo: Demis Schroeder/NREL



David Danielson PhD '07

As the assistant secretary for energy efficiency and renewable energy (EERE) at the US Department of Energy (DOE), David Danielson leads the agency's efforts in high-impact research, development, and demonstration to make clean energy—from biofuel vehicles to geothermal power—cost-competitive. The position builds on his experiences, first as a clean energy venture capitalist and then as the first program director for DOE's Advanced Research Projects Agency-Energy (ARPA-E), where he led R&D programs that focused on high-risk, high-reward clean energy technologies. While at MIT, Danielson founded the MIT Energy Club.

Why do you consider energy such an important challenge, and how is your DOE office taking on that challenge?

The energy challenge has such wide implications. By transitioning to cleaner energy sources, we can confront many of our greatest national challenges: increasing national security by decreasing our dependence on foreign oil, confronting climate change, and reinvigorating our economy through innovation and advanced manufacturing. EERE is at the center of all of this and is committed to getting things like solar power and cellulosic ethanol to be commercially viable and widely adopted. What's exciting is that by tapping into America's best innovators and entrepreneurs, we're now at a point where in the next five to ten years many clean energy technologies are going to be directly cost-competitive with incumbent technologies.

How did your venture capital background change your outlook?

In my venture capital experience I came to understand that an entrepreneurial spirit, a celebration of taking calculated business risks, and a willingness to fail and get back up again are intrinsic to our American identity and to our competitive advantage. There are other countries where if you started a business and that business went under, you would be considered a failure. Cultures that don't celebrate risk-taking and tolerate failure don't tend to be as innovative as our society. Applied to the clean energy race, this spirit—combined with partnerships with innovators like we have at MIT and continued government support for EERE—can result in American leadership in this multitrillion-dollar market opportunity.

What lessons did you learn from MIT that you would like to pass on to students who are just starting out?

When I first got to MIT, I was definitely a techie's techie. I thought that it was the technical people who knew everything and should be making all the decisions. What I learned is that you need all types of people to come to the table to do good problem solving—people who understand technology and science, and people who understand public policy and business. That's something I learned from my colleagues in the MIT Energy Club. So I'd recommend that students get out of the lab and get to know other people with other expertise and try to learn from them. Sometimes this requires you to get out of your comfort zone if you want to grow as a professional and make an impact.

Photo: Justin Knight



Rhonda Jordan PhD '12

After getting her master's degree in electrical engineering from Columbia, Rhonda Jordan decided to take a break from academics to pursue her passion for dance. While dancing professionally in Angola, Jordan witnessed extreme poverty for the first time. The experience pushed her to want to help poor communities. So she decided to study engineering further at MIT, where she joined with classmates to form EGG-Energy, a startup that connects low-income customers in east Africa to electricity. She received her PhD from the MIT Engineering Systems Division (ESD) in 2012. She spent spring 2013 as a consultant at the World Bank researching power system planning and clean energy, and she recently became an energy specialist in the Energy Unit of the World Bank's Sustainable Energy Department.

What led you to want to not just help the poor but bring them electricity?

When I was dancing in Angola, I saw people who lived in mud huts without running water or electricity. The experience made me realize that in the Western world, we consume exorbitant amounts of electricity, and we don't even notice it. When I saw how people had to live when they didn't have it, it really opened my eyes. I wouldn't be where I am if I didn't have lights to allow me to study in the evening, or if I had to spend most of my time gathering wood for cooking. So I decided to put my engineering skills to work, went to MIT, and studied power systems in developing countries.

How did EGG-Energy start, and what progress have you made?

After I returned from Africa, I joined with MIT PhD student Blandine Antoine (ESD) and Jamie Yang PhD '08 (Nuclear Science and Engineering), who wanted to think of a way to improve access to electricity in the developing world. We came up with a plan and won some funding from the MIT IDEAS Competition. We decided to distribute batteries and set up charging stations, some running on hydro and thermal (via the grid) and some running on solar. Now we reach about 4,000 people. One of our customers came to the charging station and brought his kerosene lantern and said, "This is a gift for you. I don't need this anymore." Reducing the use of kerosene, and thereby cutting emissions and air pollution, is one great accomplishment.

You've had a multifaceted career—from dancing to entrepreneurship. What do you see yourself doing in the future?

My mom always tells me, "You can do all of the things that you want to do. It's just a matter of timing and sequence." So I haven't figured out the sequence yet, but I would like to someday teach. I also want to continue going into the field to help countries with electrification planning—something that MIT, and specifically the Energy Initiative, has helped me do. And I want to open a dance school, because the arts taught me a lot of discipline that was very helpful as I pursued academics.

Photo: Jennifer Schley Johnson



Jeremy Johnson PhD '06

In 2003, chemical engineering PhD student Jeremy Johnson was assessing the economic and environmental performance of biomass when his classmate Michael Raab PhD '06 had an idea. What if they could degrade the cell wall of feedstock with enzymes and produce low-cost sugars for fuel? With Johnson's background in comparing biofuel technologies and Raab's background in designing them, the two decided to team up and create Agrivida—a company focused on developing and commercializing this technology. Since then, Agrivida has received funding from major venture capital firms, the National Science Foundation, US Department of Energy (DOE), and US Department of Agriculture. DOE recognized Agrivida with an Energy Innovator Award, and the company received visits from former DOE Secretary Steven Chu and Department of Agriculture Secretary Tom Vilsack.

Why did you decide to co-found a startup?

While I know a lot of people come to MIT with the idea that they want to start their own company, I wouldn't say I came with that goal in mind. But the entrepreneurial spirit rubbed off on me. When I first got to MIT, one of the students in my research group won the \$100K Business Plan Competition. I thought that was the coolest thing that he had won. So the following year, when Mike Raab came to me with his idea and wanted my help writing a business plan for the competition, I jumped at it. We didn't win, but the idea of continuing to work on it seemed exciting. So I did it.

What did you learn from your experience at MIT that has helped you with Agrivida?

My thesis involved looking at data and quantifying uncertainty to help decision makers gauge which facilities were worth building or which biofuel policies would work best and be the most cost-effective. In running the company, I need to make decisions like which experiments to run or which projects to focus on. In making those decisions, there's a lot of uncertainty in how the technology will work and how the markets will play out. So I use the same tools and thought processes for managing uncertainty that I used at MIT.

What advice would you give MIT students looking to form their own energy startup?

I would say to take advantage of all the resources that MIT has to offer. The Entrepreneurship Center and Venture Mentoring Service were both helpful in getting us started. But beyond services like those, it's also important to get involved with clubs like the Energy Club. I tend to be an "everything on board" person, where I value having a good understanding of what's going on in the solar industry, the natural gas industry, the electric car industry—along with the biofuels industry. It's important to know the different energy alternatives out there and understand how your expertise or your specific technology option might fit in. That's where interacting with many different people through the Energy Club can be helpful.

• • •

By Victoria Ekstrom, MITEI

The MIT Energy Club: Building the energy community on campus and beyond

More than a thousand students strong and growing, the MIT Energy Club is the largest student group on MIT's campus—and one of the largest clubs of its kind in the nation, with more than four thousand general members worldwide. The club has succeeded, co-president Sam Telleen says, because of its dedicated members and strong relationships with organizations on and off campus—such as the MIT Energy Initiative.

Once hooked, students often find the club to be like a second job, says Lara Pierpoint, co-president in the 2008–2009 academic year. Pierpoint says her PhD advisor, founding director of the Energy Initiative Ernest Moniz, used to joke that “I had two full-time jobs. The more important one was Energy Club president, and second to that was my work for him.”

As the Energy Club approaches its 10th anniversary next year, club members—past and present—reflect on the club's roots, influence, and future.

The beginnings

The story of the Energy Club's short but remarkably successful history starts with a teacher's challenge and a broke, eager student.

David Danielson, a PhD student studying solar energy, took a class on sustainable energy in the spring of 2004. The professors teaching the class were in the midst of publishing a book, and they challenged their students to catch their mistakes, promising a dollar for each mistake found. Danielson pulled two all-nighters and made about \$300.

“During the course, I noticed there was a two-way dialogue happening between the students and the professors, but we

[the students] weren't talking to each other,” Danielson says. So at the end of the semester, Danielson emailed the class asking if they wanted to put their book challenge money toward a pizza and beer fund, then meet at the nearby Muddy Charles Pub to talk about energy. The Energy Club was born.

By the end of summer 2004, the club had grown to about 30 members, and a few “Sloanies”—as the business students from MIT's Sloan School of Management are affectionately called—started showing up.

“We were a bit dubious about their motives because we were technologists and we weren't sure about those business folks,” Danielson recalls. “But then as they contributed to the discussions, we came to learn they had phenomenal expertise and talents that were totally different from ours and from which we could learn.”

One lesson was that the business students “liked to go big,” Danielson says. Nolan Browne was one such “Sloanie.” At Sloan, Browne felt isolated, but in exploring MIT's labs and talking with professors he discovered he wasn't alone. The people he talked with didn't seem to know each other. “They felt in a bubble, like I did,” Browne says.

Danielson and Browne had succeeded in bringing together a small group of grad students, but Browne recalls thinking, “Wouldn't it be great to have a venue where MIT as a community can come together and learn from each other?” So at one of the meetings, Browne proposed holding a conference.

“My limited experience with leadership at that time was that people can get really excited about an idea, but then

when you ask, ‘OK, who's willing to commit to help us execute the idea,’ all the hands would go down,” Danielson says. This time, the opposite happened. Everyone's hands stayed up.

All these years later, Browne described the first Energy Conference, in spring 2005, as “incredibly stressful” but “incredibly fun.”

“What made the Energy Conference great was the quality of the ideas brought to the table, the commitment of the team, and the multidisciplinary reach,” Browne says. “The conference definitely got the attention of the energy community in the US.”

The club today

Since the first informal gatherings at the Muddy Charles, the club's membership has skyrocketed. In addition to 1,200 student members, 3,300 individuals from the national energy community receive club emails, bringing total membership to 4,500. The club has also expanded its events to include a Clean Energy Prize, Energy Night, and a Finance Forum.

While the club grows bigger and stronger each year, it remains true to its mission of “building the MIT energy community through fact-based energy analysis.”

Pierpoint says the club could never successfully build an energy community on campus if it strayed into advocacy. But there was one foray into advocacy. When the MIT administration wanted to close down the Muddy Charles Pub, Pierpoint and others sprang into action to save their beloved clubhouse—and it worked.

Otherwise, “We were never going to be an advocacy organization,” Pierpoint says. “The purpose of the club was always to understand energy across the board...and make sure everyone felt welcome.”

Telleen notes there aren’t many organizations that unite people across campus to quite the same extent. “This is one of the few I’ve seen that brings so many disciplines in,” he says. “It’s a great representation of the energy sector in general.”

Not only does the Energy Club reflect the energy sector, it also exhibits the values of MIT, says Addison Stark, a president of the club during the 2010–2011 academic year. He describes how MIT’s central group of buildings were designed to blend together: “There’s no separation of buildings, so the hope was that people from the chemistry department would be walking along and find their way to civil engineering, and then accidentally run into somebody whom they would never meet if they were in separate tall, old ivy towers.”

The club is the same way, Stark says. “It allows you to learn something new from somebody who you wouldn’t otherwise interact with. It’s purposely designed to allow members to brush shoulders.”

From this “brushing shoulders,” friendships develop and members meet “the people who are going to be part of your life, hopefully, 10 or 20 years from now,” Telleen says.



Photo courtesy of the MIT Energy Conference

The eighth annual MIT Energy Conference—From Idea to Impact: Collaborating to Meet Global Energy Challenges—was held on March 1–2, 2013, and featured panel discussions by leaders from energy industries and academia as well as keynote addresses by former Energy Secretary Bill Richardson and by David Crane, CEO of NRG Energy, the nation’s leading independent power generator. Here, Richardson (third from left) and MIT President L. Rafael Reif (far right) pose with student organizers of the conference, including managing director Daniel Connell (second from left).

Beyond campus

Ask members of the Energy Club why they devote so much time to the club and most will cite the relationships they’ve formed—both personal and professional.

“I came in really wanting to make an impact and wanting to push the thinking in energy,” current co-president Richard Zhang says. “Then I got involved and became part of the organization and developed friendships. That’s a pretty strong motivator for continuing to be active.”

After leaving MIT, those relationships continue, as members working in startups, corporations, or government find themselves popping up in each other’s lives. And they’re always happy to help a fellow club member.

Browne says being part of the club can help lead to valuable alumni-student interactions and job offers. Daniel Enderton, a president in the 2007–2008 academic year, can attest to that. “My work through the club led directly to the job I had afterwards [at the MIT Energy Initiative] and the job I have today [vice president of business development at C12 Energy].”

Beyond the lessons learned and connections made by members, the

Energy Club has served as a model for similar clubs throughout the world. An umbrella organization, also modeled after the club, ties them all together: the Collegiate Energy Association.

When giving advice to others hoping to start their own energy club, Telleen tells them it’s really about “understanding your community and ecosystem on campus”—advice the club continues to model by example.



By Victoria Ekstrom, MITEI

Those who shared their views for this story include: Nolan Browne MBA ’06, managing director and co-founder of the Fraunhofer Center for Sustainable Energy Systems; David Danielson PhD ’07 (materials science), assistant secretary for energy efficiency and renewable energy, US Department of Energy; Daniel Enderton PhD ’08 (climate physics and chemistry), vice president of business development, C12 Energy; Lara Pierpoint PhD ’11 (engineering systems), AAAS Congressional Science and Engineering Fellow, US Senate Committee on Energy and Natural Resources; Addison Stark PhD ’14 (expected—mechanical engineering); Samuel Telleen MBA ’13; Richard Zhang PhD ’15 (expected—electrical engineering).

Tata Center students spot opportunities to innovate in India

Taking MIT's "Mens et Manus" (Mind and Hand) motto to heart, the new Tata Center for Technology and Design is pioneering a multidisciplinary approach to problem solving in the context of developing countries.

"We are giving our students a unique opportunity to immerse themselves in settings where societal needs and aspirations are no different from anywhere else, but where poverty and limited access to technical capacity, materials, and energy, for example, create an unfamiliar and very challenging solution space for engineers and entrepreneurs," says Robert Stoner, the program's co-director and MIT Energy Initiative (MITEI) associate director.

Launched in April 2012 and headquartered at MITEI, the center was funded by a gift from the Sir Dorabji Tata Trust to pursue a unique educational mission. The center selects incoming master's degree students from a wide range of MIT departments to become Tata Fellows. Working closely with the program directors and their departmental advisors, fellows will travel extensively to India over the course of their two years of study, pursuing thesis projects that respond to rural and urban needs throughout India. Each student must identify a challenge and propose a practical design solution shaped by technical requirements as well as business, economic, and social considerations.

The ambitious program, which so far includes projects focused on energy, water, healthcare, agriculture, and housing, calls on students to be simultaneously creative, pragmatic, and entrepreneurial. It has proven an irresistible opportunity for some. "I wanted to do something for India, apply what I was learning, and contribute to solving a major social problem,"

says Bhushan Desam, whose master's and PhD research at the University of Utah concerned water treatment and combustion-generated pollution. Desam learned about the new Tata Center after arriving at MIT to pursue a master's degree in system design and management. A native of India, he leaped at the chance to apply "because I thought I might be able to contribute my expertise to help solve some of the many energy and environmental challenges there."

Desam traveled to India with other members of the inaugural class of 17 Tata Fellows. "Our faculty said talk to people, see the needs, and find a project," he recounts. Led by MIT Sloan Professor Charles Fine, the other Tata Center co-director, Desam's

group investigated possibilities in Muzaffarnagar, which is home to sugar refineries, paper mills, and rice processing plants that discharge their waste products into rivers or burn them, polluting the environment. Local industry leaders, deeply worried about these environmental toxins, told the Tata team that they keenly sought affordable technologies for controlling this pollution.

Tata projects require close collaboration with local partners, and Desam found a paper mill owner with a specific problem: "This man has a lot of plastic mixed into his recycled paper. He wanted to find some way of using the plastic and helping the environment," says Desam, "but he couldn't do his own R&D." Desam's research resulted in a business prospect enthusiastically



Natasha Wright (center front), Tata Fellow and graduate student in mechanical engineering, meets with women residents of a village in Maharashtra, India. The steel point-of-use filtration system (shown in photo) is commonly found in rural villages. Wright is studying existing water purification technologies in villages like this to determine what works well and what changes residents might like to see. Interviews with local residents helped to reveal the advantages and disadvantages of community-based versus point-of-use systems.

Photo courtesy of Natasha Wright G, MIT

Photo courtesy of Bhushan Desam G, MIT



At a paper mill in Muzaffarnagar, Uttar Pradesh, India, Tata Fellow Bhushan Desam of the System Design and Management Program examines waste plastic mixed in with recycled magazines, books, and cartons. This material is currently burned directly as fuel, creating significant environmental pollution. Desam’s project aims to convert the plastic instead into valuable products such as fuel oil.

Photo courtesy of Emily Gorbaty G, MIT



Hosted by several international NGOs, Tata Fellow Emily Gorbaty of mechanical engineering (third from left) meets with a women’s self-help group in a tribal village in Jharkhand, India, to learn about their lives. Gorbaty is now designing a fuel-efficient pumping system that utilizes a portable submersible pump and could make groundwater irrigation economically feasible for many off-grid smallholder farmers.

embraced by the paper mill owner: the idea of burning locally abundant sugar cane waste, a carbon-neutral fuel, to power the conversion of recycled plastics into valuable diesel oil. “I’m looking at the kind of technology we should implement, and the economics of the situation, to come up with a solution that makes some money and cleans up the environment, too,” Desam says.

The solutions that Tata Fellows work on “may span several generations of students,” says Fine. Successive teams might lead the discovery and problem formulation stages, conceptual design, prototyping, and testing in labs and in the actual environment. But all aspects of these projects require proximity to native stakeholders. “We need to know if our solutions are culturally appropriate and fit the lives of the people who will use them,” Fine says. “Our hope is to create a program and curriculum that delivers knowledge and an experience base to students—and delivers projects of real value to people with real needs and fewer resources than people in the US.”

Among other things, students find themselves confronted with daunting cost targets. To equip students to meet these targets, the program will build on some of the low-cost design concepts championed by Ratan N. Tata, former chairman of the Tata Group global conglomerate, whose motor company created the Nano, a technologically sophisticated, ultralow-cost passenger car for Indian consumers. A member of MITEI’s External Advisory Board, Tata engaged MIT to realize his vision: an educational program to produce a new generation of entrepreneurial engineers who can seize technological opportunities in the most resource-constrained settings.

A core group of MIT faculty is already deeply engaged in studying products in India and other developing economies that offer helpful clues. As Stoner points out, “We’re finding that it’s not about trying to make something cheap, but rather about making it less costly and at the same time better.” In India and other emerging nations, he says, “people want nice cars, houses, appliances, ovens, computers, medical care... It takes a considerable amount of ingenuity and market awareness to make something much less expensive but also pleasing, and of course, functional.” It will be incumbent on Tata Fellows seeking meaningful ventures “to look at all the barriers that prevent people from accessing modern lifestyles across a wide range of activities,” he says.

Initial project ideas range from self-contained electrical grids built on a village scale and low-cost food processing systems to affordable medical diagnostic and treatment technologies, including prosthetic limbs. For one venture, under the direction of Assistant Professor Amos Winter and the Global Engineering and Research Lab, Tata Fellow Natasha Wright has begun designing inexpensive, village-scale, solar-powered water purification systems. Teamed up with Jain Irrigation, an Indian company, she is devising technologies to eliminate not only unpalatable salts from the often highly saline groundwater but also the microbial and chemical contaminants that prove a hazard for villagers relying on wells or river water, especially during monsoon season.

Existing technology to remove these dangerous impurities may prove too expensive for families who earn just a few dollars a day. Maintenance brings additional costs, if parts and skilled



Photo: David Taylor G, MIT

In urban centers in India, some people connect suction pumps directly to the water system to siphon water out of the network—a practice that reduces system-wide pressure and can even pull sewage into the water mains. Tata Fellow David Taylor of mechanical engineering is developing a robust, purely mechanical device that will stop personal pumps from siphoning off water but not interfere with their ability to increase water pressure within a home. Here, Taylor watches a Mumbai repair crew install a new pipe fitting—without using any power tools.

labor are even available. Wright, a first-year mechanical engineering master’s student, must crack these problems, as well as the issue of cultural acceptance. “Some households prefer clay pots, called gharas, to keep their water cool, but these pots have a wide opening allowing for recontamination.” She intends to build and field test a cluster of adaptable solutions before completing her degree in 2014.

In spite of these formidable challenges, Wright says the project “is a perfect fit” for her. The fellowship drew her to MIT for graduate studies and, she concludes, “pursuing high-level research and applying it to a real-world product of global importance—that really speaks to me.”

Stoner, Fine, and their collaborators believe that this kind of passionate engagement will make a tangible impact on the world, and in a relatively short period of time. With between 20 and 30 new students joining the Tata Center each year, a broadening curriculum, and an increasingly knowledgeable and committed faculty team, they envision that by the end of five years, students will have completed more than 150 projects that touch all segments of Indian society, allowing many more people there to experience modern life as we experience it.

• • •

By Leda Zimmerman, MITEI correspondent

Energy savings add up to success for Efficiency Forward

The NSTAR-MIT collaboration known as Efficiency Forward has transformed the energy landscape on campus in just three years, reducing the Institute's energy footprint by 34 million kilowatt-hours (kWh) per year, producing an estimated lifetime savings of \$50 million, and preventing more than 20,000 metric tons of greenhouse gas emissions from entering the atmosphere annually.

Light sensors, smart thermostats, LED bulbs, energy-saving refrigerators—as well as the construction of super-energy-efficient LEED-certified buildings—have all helped the Institute meet this ambitious goal.

“Energy doesn't just go to lighting, so it's really wonderful that [MIT has] the richness of the diversity of savings.... I see that as a trend that's going to continue,” says John Kibbee, NSTAR's program manager for Efficiency Forward.

“The team implementing Efficiency Forward has been tireless in its pursuit of smart, efficient measures all across our campus,” says Israel Ruiz, MIT's executive vice president and treasurer. “We are appreciative of our collaboration with NSTAR and the valuable contributions from our faculty, students, and staff to make the program such a success.”

Designed to build on MIT's strengths to create a model program that would meet state greenhouse gas reduction goals, Efficiency Forward is the single largest energy-efficiency project that gas and electric utility NSTAR has ever developed with a customer. Together NSTAR and MIT invested more than \$13 million in energy conservation over the program's three-year period to meet their targeted goal of reducing the Institute's energy

consumption by 34 million kWh per year (approximately 15%).

“[Efficiency Forward is] important to us because it was groundbreaking in its creativity in terms of creating a streamlined way to work with customers,” says Kibbee, noting that MIT and NSTAR have been jointly managing 35-50 projects a year, with NSTAR providing incentives and expertise to support MIT's own energy-saving initiatives. “Naturally, we wanted that first example to be a shining example, and MIT has been all of that.”

The program has also been extremely valuable to MIT, according to Megan Kefalis, project manager in the Department of Facilities' Systems Engineering Group. “The importance of this type of program is it helps us to think about ways to operate our buildings better,” she says. “It's been a great thing for MIT.”

“We are thrilled to have been able to make such a contribution to moving the dial on energy efficiency—both on campus and in the region,” says Ruiz, who also serves as co-chair of the MIT Energy Initiative's Campus Energy Task Force.

Projects run the gamut

Efficiency Forward was able to meet its energy-reduction goals in large part due to the efficiency embedded into new buildings, including the Sloan School of Management and the Koch Institute for Integrative Cancer Research, which both earned Leadership in Energy and Environmental Design (LEED) Gold certification. “[During construction is] the best time to invest in efficiency. You can put in better windows and insulation in walls; that's hard to do as

retrofits,” says Peter Cooper, MIT's manager of sustainable engineering and utility planning.

Approximately 40% of the program's overall goal was met through new building features. Another 40% came from upgraded lighting and associated controls, while 20% of the goal was met by improving the efficiency of mechanical systems and systems for heating, ventilation, and air conditioning (HVAC).

No new buildings came online in 2012, so MIT had to dig a little deeper to find energy savings. Two new initiatives that helped the program achieve its goals last year included replacing 653 refrigerators in residence halls with new, energy-efficient models, and distributing 10,000 LED light bulbs on campus to replace less-efficient incandescent or compact fluorescent bulbs.

NSTAR supplied the full-size refrigerators and provided the new bulbs at a deep discount. MIT handled the work both of moving the refrigerators and of distributing the bulbs to students and staff. The refrigerator program alone is expected to save 300,000 kWh per year. The light bulb initiative, which replaces 60-watt bulbs with new lamps that use just 12.5 watts, has the potential to save 1 million kWh annually, according to Kefalis.

The bulb distribution effort works by encouraging individuals to trade in old bulbs for new ones, thereby serving as an informational campaign for the MIT community. “I think [Efficiency Forward] is really spreading the word of energy efficiency and showing that it's not as hard or as expensive as it may originally appear,” Kefalis says.

If there's one message the community can learn from the program, it's that small efficiencies do add up. That's why MIT uses sensors to continuously monitor building control systems, enabling Facilities staff to flag potential problems, such as a leaking heat valve or the simultaneous operation of heating and cooling systems. "The monitor-based commissioning program has been working for a few years, but we rolled it out to many more buildings last year," Kefalis says, providing 1.8 million kWh's worth of energy savings.

New energy-saving efforts

To draw even more savings from MIT buildings, in 2012 MIT installed smart thermostats for the first time in a pilot program under way in the Sidney-Pacific graduate student residence hall (NW86). These thermostats are controlled by occupancy sensors that detect when someone enters the room and adjusts the temperature accordingly. "Say you like the room at 72 degrees," Kefalis says. "When you leave, it senses that you're gone and within a half-hour period it will drop the temperature, saving energy while you're not there." MIT is still assessing the value of the smart thermostats, but Kibbee says the pilot program has the potential for "big, big, big savings."

MIT's expanded portfolio of energy projects also included installing variable frequency drives on water booster pumps, which allow the pumps to speed up or slow down based on demand. In addition, Facilities has made improvements to the compressed air system on campus, which is used for certain lab activities as well as for HVAC. "We created a central distribution system for compressed air to



Photo: Melody Craven, MIT Department of Facilities

Among the many MIT buildings getting lighting upgrades is Simmons Hall (Building W79), an on-campus residence that houses 344 undergraduate students. To date, the Simmons upgrades have saved more than 450,000 kWh.

replace many satellite compressors," says Kefalis. This work is saving the Institute 900,000 kWh per year.

Looking forward, Cooper says the Institute is committed to another three years of Efficiency Forward, although NSTAR and MIT are still working out what the new energy savings goal should be.

"We're looking at what we can do and what commitment we can make," Cooper says. "We don't have any energy-intensive lab buildings coming on in the next three years, and we've done almost the whole campus in terms of lighting, so the projects may be in the form of more refrigerators, but mostly

they will be mechanical and HVAC. Our experience is that these take more than a year and they're more complicated to do."

Kibbee says, "It's just a matter of getting all the details right....I think the future bodes very well."

• • •

By Kathryn M. O'Neill, MITEI correspondent

MIT plans energy-saving upgrades to Main Group

As MIT approaches the 2016 centennial of its move to the William Welles Bosworth–designed Cambridge campus, the Department of Facilities is working to ensure that the buildings of the Main Group are prepared to meet the demands of the next 100 years—including the need for energy efficiency.

While a wholesale renovation of the central campus buildings surrounding Killian Court, known as the Main Group, is too massive and expensive to undertake all at once, planners have been working to prepare guidelines that will ensure future projects respectfully equip the buildings to meet modern needs.

“What we are looking at is how can we address today’s energy realities and do it in a way that’s supportive of stewardship of the architectural integrity of the buildings,” says Gary Tondorf-Dick, program manager for Facilities’ Campus Planning, Engineering, and Construction Group. “That’s what sustainable design is all about. It’s good planning.”

Recently, the department concluded a three-year pilot project to assess the best replacement windows for the Main Group. Replacing the windows promises to provide enormous savings, because the current windows, all single-paned, are so huge. Typical two-story windows in the Main Group are 8 feet wide and 27 feet tall, with the largest measuring a staggering 36 feet in height.

“The loss of weather tightness of the Main Group windows after 100 years is always a focal point of energy-waste angst by the community, but knowing what to do about it is not as easy as it may initially seem,” says Steven M. Lanou, deputy director for environmental sustainability and a member of the Campus Energy Task Force of the MIT Energy Initiative.

To address this issue, Facilities examined restoration and replacement options for the buildings’ windows and exterior masonry. In 2010, three different types of windows were installed at the southeast corner of Building 2, and 60 sensors were positioned to monitor the temperature and humidity inside the masonry wall.

Facilities then researched the performance of four glass options, one of which—argon-filled insulated glass—was dismissed early due to problems meeting MIT’s requirements that the new window system be long-lasting and fit within the available depth of the wall as it passes by the second floor.

Three options were implemented in a mock-up at the southeast corner of Building 2: single plate; vacuum-insulated glass, which features two layers of glass with an evacuated interstitial space between them; and a double window (with an interior storm window) featuring two layers of single-plate glass with outside laminated safety glass.

After analyzing the data accumulated over the years, the department has now determined that windows with vacuum-insulated glass will provide the most energy efficiency at the best price over the long term. Facilities continues to investigate options related to various components and to the functionality of the window system in an effort to improve efficiency and cost.

Without changing the look of the buildings, the glass in the new windows promises to be four times as energy-efficient as the glass in the buildings’ existing, single-paned windows; however, thermal conduction through the frame reduces that ratio for the overall window systems, says Tondorf-Dick. “We want to do upgrades without

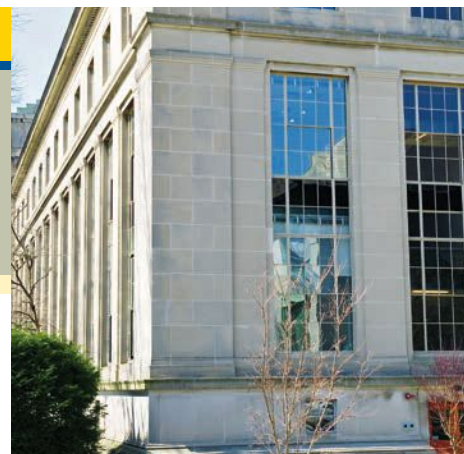

Photo: Stuart Darsch

A three-year pilot test of three types of windows at the southeast corner of Building 2 has enabled MIT Facilities to identify a replacement window system that should provide significantly higher energy efficiency than the windows now in the Main Group do—without compromising the architectural integrity of the buildings.

compromising the architectural integrity of the buildings—and that’s not just aesthetics, that’s about how comfortable it is, how [occupants] can control their own spaces.”

The Bosworth buildings were elegantly designed and well built, employing natural ventilation and ingenious techniques to draw daylight into the interior, such as transoms with translucent glass, which refracts light into the corridors. However, the past century has taken its toll, and piecemeal repairs have left some windows inoperable.

“A hundred years ago, we didn’t have many ways to keep steel from rusting,” says Joseph Gifun, director of Facilities’ Systems Engineering Group. “They didn’t have the kind of materials we have today, [such as] energy-efficient glazings and protective coatings.” Through diligent studies such as the recent windows pilot, MIT is preparing to properly upgrade the Main Group for another century of service.

It’s a slow process, which is why Facilities is still analyzing options for reducing heat transfer through the masonry. “We have to be very careful,” Tondorf-Dick says. “The Main Group is the icon.”

• • •

*By Kathryn M. O’Neill,
MITEI correspondent*

Exploring energy game changers: Moving technologies from lab to marketplace

On March 7, 2013, researchers from the MIT Energy Initiative and Stanford's Hoover Institution met in Washington, DC, to explore the latest energy technologies and to advocate for stronger and sustained investment in research and development to help move these technologies from the lab to the marketplace.

The gathering was the third and last in a series of meetings aimed at identifying "game-changing" energy technologies.

These clean energy technologies, meeting participants argued, can boost America's long-term economic growth and allow us to confront our nation's growing energy needs, security concerns, and environmental challenges such as climate change.

"We are on the cusp of a much better energy future than we have ever had," said the Hoover Institution's George Shultz, Secretary of State under President Reagan. "We can get it if we play our cards right."

Game-changing technologies

During the daylong event, the researchers examined three critical technology areas: transportation, electricity and the built environment, and infrastructure.

The first panel, chaired by Sally Benson, director of Stanford's Global Climate and Energy Project, focused on transportation and the need to reduce oil dependency. MIT Professor Gregory Stephanopoulos spoke about creating renewable biomass from algae. His MIT colleague Daniel Cohn then explained the process of turning natural gas into a liquid fuel to create super-efficient vehicles at a low cost. Representing Stanford, Yi Cui spoke about the future of battery technology.



Photos: Jay Mallin Photos

MIT Energy Initiative's Robert Armstrong welcomes participants and attendees for the day's events.

Arun Majumdar, Google's director of energy initiatives and founding director of ARPA-E in the US Department of Energy, chaired the second panel and turned attention toward low- or no-carbon innovations. Vladimir Bulović, director of MIT's Microsystems Technologies Laboratory, highlighted the creation of paper-thin photovoltaics and ways to integrate solar cells into transparent surfaces.

"The windows that you have to be utilizing every day can become active surfaces," Bulović said, eliminating the installation cost of the solar panels themselves. While achievable, these cutting-edge technologies are at least a decade away from being used at a large scale.

Also on the panel, David Parekh, vice president, research, and director of United Technologies Research Center, spoke about the need for energy-efficient buildings, while Stanford Professor Emeritus Burt Richter gave an overview of nuclear energy.

The final panel, which explored the need for a smarter, more secure energy infrastructure, was led by Munther Dahleh, associate head of MIT's Department of Electrical Engineering and Computer Science. MIT Professor

Saurabh Amin talked about the need to create a resilient energy infrastructure protected from the threat of cyber-attacks, while the Lawrence Livermore National Laboratory's Julio Friedmann spoke about advances to the smart grid.

The Hoover Institution's Gary Roughead ended the panels with a talk on defense energy needs. He said that energy was central to the military. But at the end of the Iraq War, he noted, "energy was also costing us lives" because at least one young American died per fuel convey. Since then, the military has begun using more solar energy and biofuels and improving efficiency.

Sizable, sustained R&D

Some of the technologies discussed during the panels are ready to be deployed but are on hold because of the need for policy action. Others—though full of potential—require either a strong R&D push to make them market-ready or sustained R&D support and many more years of research before they can be fully realized. On this front, the research community faces a significant challenge: lack of funding.

Professor Robert Armstrong, then-deputy director of the MIT Energy



Secretary George Shultz, distinguished fellow at Stanford's Hoover Institution (left), and MIT President L. Rafael Reif give introductory remarks.

Initiative, quoting comedian Will Rogers, said, "Even if you're on the right track, you'll get run over if you just sit there." Without strong investments in research and development, that is what America will be doing.

According to a recent report from the American Energy Innovation Council, to maintain America's competitive edge and strong economy, the nation needs sizable, sustained investments in clean energy innovation. The council estimates the minimum amount to sustain this would be \$16 billion per year—\$11 billion over the current spending of about \$5 billion.

MIT President L. Rafael Reif said this research is "worth every penny."

"Today, as the world faces grave challenges around energy, climate, and related challenges of water and food, society needs the creative force of its universities more than ever," he said.

The innovation triad

Where will the money come from? Those participating in the conference agreed that the necessary investments in R&D must come from both government and industry. Collaboration on both fronts is critical, MIT President Emerita Susan Hockfield said, with industry bringing valuable knowledge about the marketplace to research that will need to meet the needs of that marketplace.

"What's absolutely required for us to accelerate progress on sustainable energy is to more tightly link research to development to deployment," Hockfield said. The way to go about that is through "the tried and true innovation triad of government, academy, and industry." Through this collaboration, she said, we can "speed the transition of great ideas into great actions."

She cited the creation of public-private partnerships as one of the most important recommendations from President Obama's Advanced Manufacturing Partnership, which she co-chaired.

Preparing future innovators

Reif and Hockfield both emphasized that the need for deep collaboration and support is important not just for the realization of the projects discussed at the meeting but also to feed the visions of a generation of future innovators.

Reif pointed out that budget figures don't capture the number of brilliant young scientists and engineers who, discouraged by a lack of funding, could walk away from research, causing the United States to lose a generation of transformational energy ideas.

Hockfield called these young people "our secret and most powerful weapon."

"We have a big responsibility to the next generation to draw out the plans for where the highways are going to go," she said. "We've got an army coming along who will be happy to march along them and make many of our ideas reality."

• • •

By Victoria Ekstrom, MITEI



Panel discussion on "Electricity and the Built Environment: Decarbonizing Energy," chaired by Arun Majumdar, director of energy initiatives at Google (far left). Panelists include (left to right): David Parekh, vice president, research, and director, United Technologies Research Center; Burt Richter, director emeritus of the Stanford Linear Accelerator Center; and Vladimir Bulović, director of the MIT Microsystems Technologies Laboratory.

At MIT, Gov. Deval Patrick highlights clean-energy achievements

In an Earth Day address at MIT in 2008, Massachusetts Gov. Deval Patrick outlined an ambitious set of goals that he said could achieve significant reductions in greenhouse gas emissions and create businesses and jobs based on clean-energy solutions. In a follow-up talk on April 25, 2013, he described a series of successes in achieving these goals.

“Five years ago,” MIT President L. Rafael Reif said in introducing Patrick, the governor “delivered an inspiring challenge: He argued that the Commonwealth could improve its environment and its economy by leading the way in energy efficiency and clean-energy innovation.”

In the ensuing years, Reif said, Patrick delivered on that promise: “Today, thanks to his leadership, Massachusetts ranks first in the nation in state-level energy efficiency.”

In addition, Reif said, “Harmful pollution and emissions are both declining, and clean-energy jobs are on the rise. Massachusetts has proven by example that we can have a strong economy and a healthy environment.”

Patrick said that five years ago, “We in Massachusetts took a fresh look at our energy future.” He noted that “with no oil, coal, or natural gas of our own, we are at the end of the pipeline and are subject to the whims of a global energy market.”

To address that, Patrick pushed for three pieces of legislation, he said: “First, the Green Communities Act enabled us to set ambitious goals for renewable energy: 250 megawatts of solar by 2017 and 2,000 megawatts of wind by 2020.” (The Commonwealth had previously



Photo: Dominick Reuter

Massachusetts Gov. Deval Patrick speaks at an MIT Energy Initiative event held on April 25, 2013, in Kresge Auditorium. In his talk, he detailed Massachusetts’ accomplishments since his MIT speech five years ago and then outlined new goals.

produced only 3 megawatts each of solar and wind energy, he said.)

The second piece of legislation, called the Global Warming Solutions Act, set a series of goals for reductions in greenhouse gas emissions, calling for a reduction of 25% (from 1990 levels) by 2020, and a cut of 80% by 2050.

The third piece was the Green Jobs Act, aimed at “capturing the opportunities to foster innovation and create jobs,” Patrick said. Currently, 80% of money spent on energy in Massachusetts goes to out-of-state companies. But by creating new clean-energy businesses here, he said, “With the world in the midst of an energy revolution, we were convinced that if we got this right, the world would be our customer.”

In summarizing the outcomes of those actions, Patrick said, “I am here to report that it’s working.” For example, he said, “The American Council for an Energy-Efficient Economy has ranked Massachusetts the No. 1 state in energy

efficiency for two consecutive years—ahead of longtime leader California.”

The governor added, “We installed more than 100 megawatts of solar power last year alone—ranking us sixth last year in total capacity added.”

Not only has this been good for the environment, but it has been good business, he said: “There are nearly 5,000 clean-energy firms in Massachusetts today, employing some 72,000 people—an impressive 11.2% growth in jobs in just the last year.”

There’s more in store: With the nation’s first offshore wind farm about to be built in Nantucket Sound, and a test facility for turbine blades in Charlestown, he said, “The US Department of Energy projects 20,000 jobs by 2020 in offshore wind. Why not host those jobs here in Massachusetts?”

Patrick also outlined a next crucial area of environmental sustainability: “We see water innovation as the next

IEA Outlook forecasts upheaval in worldwide energy system

opportunity for Massachusetts to seize," he said. "The same concentration of brainpower in this and other world-class universities and research facilities that spawned and feeds the life sciences and high-tech revolution in Massachusetts is at the center of this next big push in water innovation."

Although the focus of the MIT Energy Initiative-sponsored talk was Earth Day and environmental issues, Reif's introduction also alluded to the governor's leadership since the Boston Marathon bombing. "I believe I can speak for the entire MIT community in saying thank you for your leadership over the past 10 days," Reif said. "It has been a terrible and confusing time, and you offered calm, clarity, sympathy, and reassurance."

Patrick noted those events also, including his attendance at the April 24 memorial service: "Yesterday's tribute to Officer Sean Collier was beautiful and fitting," he said. Also, he said, despite the tragic events, "One shining remnant of this experience has been the re-emergence of a strong sense of community, the notion of common stake and common cause."

He said that in light of that, "I am convinced that there isn't a single challenge that we face in this state or in this country that can't be surmounted by a renewed sense that we have a stake in each other's dreams and struggles."

• • •

By David L. Chandler, MIT News Office

On November 28, 2012, Fatih Birol, chief economist at the International Energy Agency (IEA), visited MIT to share key findings from the newly released *World Energy Outlook*. The main message of his MIT Energy Initiative-sponsored talk: "The foundations of the global energy system are shifting substantially and rapidly."

The 2012 publication describes major shakeups in energy supply and demand around the world. As examples, Birol noted the reduction or complete phase-out of nuclear power in a number of countries as well as historically high oil prices that are slowing a global economic recovery. Fossil fuel subsidies—Birol's "Public Enemy #1 in the fight against climate change"—reached \$523 billion globally in 2011, while carbon dioxide emissions achieved a historic peak. And an energy boom in the United States is having rippling effects around the world.

By 2020, the United States will be a natural gas exporter, and oil imports from the Middle East will shrink "almost to zero," Birol said, as 90% of Gulf oil will flow to China and India. While the US becomes the world's largest oil and natural gas producer, Iraq will double its current oil production of 3 million barrels per day; China will add enough electric generating capacity to equal the current capacity of the US and Japan combined; and India will import the largest share of the world's coal.

As sweeping changes strike the energy market, the world will also be looking to lessen the effects of climate change, restricting greenhouse gas emissions to levels that keep global temperature increases below 2°C. Renewable energy sources will eventually account for half of new global capacity, but it may not be enough—and the "benefits come at



Photo courtesy of the IEA

In a lecture sponsored by the MIT Energy Initiative, Fatih Birol, chief economist at the International Energy Agency, discussed key findings of the 2012 *World Energy Outlook*.

a cost," Birol said, as global renewable energy subsidies will amount to \$4.8 trillion between 2011 and 2035. With existing infrastructure "already eat[ing] up 80% of the emissions allowed us to stay under the 2° trajectory" and little likelihood of an immediate change in energy investment policies or a carbon price among key nations, chances of meeting the 2°C target evaporate in 2017, Birol said.

The new *World Energy Outlook* does find one area of opportunity: energy efficiency. "Pushing the efficiency button," Birol notes, can boost employment, improve energy self-sufficiency, and buy the planet five more years to meet climate emissions targets.

In the past, Birol predicted the unconventional energy revolution currently under way in oil and gas production. He now hopes to see an unconventional energy revolution in energy efficiency. The gains, he said, "are within reach and essential to underpin a more secure and sustainable energy system."

• • •

Based on an article by Leda Zimmerman, MITEI correspondent (mitei.mit.edu/news/iea-outlook-forecasts-upheaval-worldwide-energy-system).

Martin Fellows, 2013–2014

The Martin Family Society of Fellows for Sustainability, established at MIT in 1996 through the generous support of the Martin Foundation, fosters graduate-level research, education, and collaboration in sustainability. The society supports and connects MIT's top graduate students in environmental studies and fosters opportunities for multidisciplinary cooperation in both the short and long term.

Brian Albert

Materials Science and Engineering
Develop high-efficiency, low-cost multi-junction photovoltaic devices

Eric Chu

Urban Studies and Planning
Address political dynamics between ongoing climate resilience efforts and sustainable development planning

Maxime Cohen

Management
Develop a policymaking model for designing subsidies for green technology adoption

David Cohen-Tanugi

Materials Science and Engineering
Develop novel nanoporous membranes for desalination

Mitchell Cook

Urban Studies and Planning
Assess the relationship between climate change adaptation and municipal finance

John Donnal

Electrical Engineering and Computer Science
Design sensors and signal processing infrastructure to monitor energy consumption

Ulric Ferner

Electrical Engineering and Computer Science
Develop software techniques to reduce energy consumption of enterprise data centers

Sasan Ghaemsaïdi

Mechanical Engineering
Develop and test a new theoretical model to predict the response of the ocean to surface storm forcing

Christopher Gilmore

Aeronautics and Astronautics
Optimize the air transportation system to minimize the overall environmental impact of aviation operations

Kaitlin Goldstein

Architecture
Improve the process and reduce the cost of delivering residential energy efficiency at scale

J. Alstan Jakubiec

Architecture
Create a comprehensive theory of the relationship between visual comfort and behavior that influences energy use and daylight availability in a space

Peter Kang

Civil and Environmental Engineering
Develop and test advanced models of flow and transport through fracture networks in geologic systems

Jonathan Kronos

Engineering Systems
Develop an industrial metabolism model to help advance effective sustainable materials management policies

Adam Paxson

Mechanical Engineering
Develop nanoengineered surfaces for dropwise condensation

Aruna Ranganathan

Management
Understand environmental regulation and sustainability initiatives at the level of the university laboratory

Rebecca Saari

Engineering Systems
Estimate economic and environmental impacts of climate and air quality policies using integrated assessment modeling

Alisha Schor

Mechanical Engineering
Develop a tool to rapidly determine lipid content of algae cells to advance economically viable algae biodiesel production

Leah Stokes

Urban Studies and Planning
Examine the politics of renewable energy deployment

Alison Takemura

Biology
Identify guiding principles for stable, sustainable bioenergy production

Stephen Zoepf

Engineering Systems
Simulate energy consumption of car-sharing services

MIT and Eni renew energy partnership

Capping what he called a successful five-year partnership between the Italian energy company Eni and the MIT Energy Initiative (MITEI), Eni Chief Executive Officer Paolo Scaroni enthusiastically renewed his company's support of MITEI on February 11, 2013.

After the ceremonial signing of the new agreement, Scaroni said he was largely motivated to begin the relationship out of a desire to "do something for the future of the world." Over the years of the partnership, Scaroni said, he has come to realize that the MIT-Eni cooperation produces "phenomenal results."

Eni is MITEI's largest industry research sponsor. A key element of the partnership has been the creation of the Eni-MIT Solar Frontiers Center (eni-solar.mit.edu), but the collaboration extends to other areas as well, Scaroni said, including research on such core technologies as reservoir management (eni-upstream.mit.edu). Eni has directly supported 100 energy researchers over the past five years, helping to make solar energy MITEI's largest area of research. In addition, Eni has supported 52 students as Eni-MIT Energy Fellows.

"This collaboration has been extremely productive by incentivizing very new and novel ideas," said MIT President L. Rafael Reif. "We celebrate this renewal, and hopefully we'll find many more solutions."

In a talk following the signing, Scaroni discussed the future of the natural gas market. He pointed out that natural gas prices vary by an extraordinarily wide margin, from about \$3 per thousand cubic feet in the United States to \$18 in Asia. There's also a wide discrepancy in the United States between gasoline and natural gas prices for an equivalent amount of energy.



Eni CEO Paolo Scaroni, left, and MIT President L. Rafael Reif shake hands as they exchange signed copies of the renewed partnership agreement between Eni and MIT.

Over time, he predicted that either US gasoline prices will go way down or natural gas prices will go way up. He also said that the discrepancies between energy prices in different regions of the world will gradually even out "as people find better, cheaper ways of moving gas from one part of the world to another."

New discoveries of natural gas will also be significant. Eni recently found one of the largest natural gas fields ever in Mozambique, believed to contain the equivalent of four years' worth of total US consumption. Because of its location and low production costs, the field should become a major new source of natural gas for rapidly growing Asian markets. But there are major uncertainties in future Asian demand, which could have a significant impact on global markets for natural gas, said Scaroni.

• • •

Based on an article by David L. Chandler, MIT News Office (mitei.mit.edu/news/mit-and-eni-renew-energy-partnership).



Paolo Scaroni, CEO of the Italian energy company Eni, delivers an address on the future of global natural gas markets.

Photos: Dominick Reuter

MITEI Founding and Sustaining Members

MITEI's Founding and Sustaining Members support "flagship" energy research programs or individual research projects that help them meet their strategic energy objectives. They also provide seed funding for early-stage innovative research projects and support named Energy Fellows at MIT. To date, members have made possible 117 seed grant projects across the campus as well as fellowships for more than 250 graduate students in 20 MIT departments and divisions.

FOUNDING MEMBERS

BP
Eni S.p.A.
Saudi Aramco
Shell



SUSTAINING MEMBERS

Robert Bosch
Chevron U.S.A. Inc.
Ferrovial
Lockheed Martin
Schlumberger
Siemens
Total
United Technologies Corporation
Weatherford International Ltd.



MITEI Associate and Affiliate Members

MITEI's Associate and Affiliate Members support a range of MIT energy research, education, and campus activities that are of interest to them. Current members are now supporting various energy-related MIT centers, laboratories, and initiatives; fellowships for graduate students; research opportunities for undergraduates; campus energy management projects; outreach activities, including seminars and colloquia; and more.

Associate Members

Alliance for Sustainable Energy
Booz Allen Hamilton
Cummins
Duke Energy
EDF

Edison International
Enel
Entergy
Hess
ICF International

Affiliate Members

8 Rivers Capital
Albachiara Rinnovabili S.r.l.
Angeleno Group
Asociación Nacional de Empresas Generadoras
Aspen Technology, Inc.
AWS Truepower, LLC
Larry Birenbaum '69
Bloomberg New Energy Finance
John M. Bradley '47, SM '49
Constellation Energy
Cooley LLP
Jerome I. Elkind '51, ScD '56
EnerNOC, Inc.
Ernst & Young LLP
Dennis Fromholzer
Fundació Barcelona Tecnologia (b_TEC)
Gas Technology Institute
Natalie M. Givans '84
C. Gail Greenwald
Thomas Guertin PhD '60
Harris Interactive
Hogan Lovells US LLP
IHS Cambridge Energy Research Associates
Paul Mashikian '95, '97

New York State Energy Research and Development Authority
Nexant, Inc.
NGP Energy Technology Partners, LP
Open Access Technology International, Inc.
Osaka Gas Co., Ltd.
Patriot Renewables
Petra Energia S.A.
Praxair, Inc.
Pythagoras Investment Management, LLC
Joseph M. Rault '48, President, Rault Resources Group
Redpoint Ventures
Philip Rettger '80
Rockport Capital Partners
S. Kinnie Smith, Jr.
Doug Spreng '65
Steptoe and Johnson, LLP
George R. Thompson, Jr. '53
The Tremont Group, LLC
Tomas Truzzi
Westport Innovations, Inc.
Xandex, Inc.

Members as of May 1, 2013



MIT Energy Initiative
Massachusetts Institute of Technology
77 Massachusetts Avenue, E19-307
Cambridge, MA 02139-4307



Return service requested

Nonprofit Organization
U.S. Postage

PAID
Cambridge, MA
Permit No. 54016



Ernest J. Moniz becomes Secretary of Energy

Ernest J. Moniz, the founding director of the MIT Energy Initiative, left the Institute in May 2013 to lead the US Department of Energy. As Secretary of Energy, Moniz oversees an agency devoted to ensuring America's security and prosperity by addressing its energy, environmental, and nuclear challenges through science and technology. Robert C. Armstrong is the new director of MITEI. Armstrong, the Chevron Professor of Chemical Engineering, served as the deputy director of MITEI since its founding. He has been a member of the MIT faculty since 1973. For more information, see pages 2 and 3.