

CENTER FOR

ADVANCED NUCLEAR
ENERGY SYSTEMS



Massachusetts Institute of Technology
77 Massachusetts Avenue, 24-215
Cambridge, MA 02139-4307

(617) 452-2660
canes@mit.edu
mit.edu/canes



ADVANCED NUCLEAR POWER PROGRAM

Light Water Reactor Heat Storage for Peak Power and Increased Revenue:

Focused Workshop on Near-Term Options

Workshop Chairman: Charles Forsberg: MIT

Discussion Leaders and Speakers:

J. Parsons: MIT, G. Haratyk: MIT, J. Jenkins: MIT, J. Wooten: Westinghouse, J. Gasper: Omaha Public Power/Fort Calhoun (retired), S. Brick: Clean Air Task Force, R. Varrin: Dominion Eng., E. Schneider: U. of Texas, N. Mann: U. of Texas, M. Doster: North Carolina State, C. Stansbury: Westinghouse, Y. Ding: U. of Birmingham, H. Bindra: Kansas State University, N. McLauchlan: MIT, T. Buscheck: LLNL, R. Lester: MIT, D. Curtis: MIT, T. Krall: Exelon, A. Sowder: EPRI, J. Jurewicz: Exelon, C. Stansbury: Westinghouse

MIT-ANP-TR-170

July 2017

For Public Distribution



Abstract
Light Water Reactor Heat Storage for Peak Power and Increased Revenue:
Workshop on Options

Worldwide electricity markets are changing due to decreasing prices of fossil fuels and addition of renewable generators (wind and solar). Large scale renewables deployment collapses prices at times of high wind or solar input that limits their deployment and impacts nuclear plant revenue. These changes have reduced the demand for base-load electricity but increased the demand for dispatchable electricity—a market currently served in the United States primarily by natural gas turbines. At the same time there is a longer-term need for dispatchable low-carbon electricity production—a replacement for fossil-fuel electricity production.

The changes may be challenging the economics of nuclear power today but may create new opportunities for existing and new-build nuclear energy systems in the future. Heat storage coupled to LWRs may enable base-load reactor operation with variable electricity to the grid—heat into storage when low electricity prices and production of added electricity using stored heat when prices are high.

To address these nuclear energy challenges the Massachusetts Institute of Technology (MIT), Idaho National Laboratory (INL), and Exelon conducted a workshop on *Light Water Reactor (LWR) Heat Storage for Peak Power and Increased Revenue* on June 27-28, 2017 at MIT. The workshop goals were to define and understand the market, regulatory, and technical options for coupling heat storage for variable power to existing and future LWRs with recommendations for the path forward to improve LWR economics. Observations and outcomes from the workshop include:

Nuclear reactors generate heat and thus couple efficiently to heat storage that is 10 to 40 times less expensive than electricity storage (pumped hydro, battery, etc.); thus potentially a lower-cost way to meet variable electricity demand. Favorable heat storage economics has resulted in concentrated solar power systems under construction to include heat storage to vary electricity production. Many of these technologies are applicable LWRs and most are applicable to other reactor types.

Six classes of heat storage technologies have been identified that can couple to light-water reactors: steam accumulators, sensible heat storage, cryogenic air storage, packed pebble-bed heat

storage, hot-rock storage and geothermal heat storage. Some storage technologies are ready for demonstration, others require significant R&D.

Heat storage systems coupled to LWRs are different from storage technologies such as batteries and pumped hydro. Batteries and pumped hydro storage have electricity input rates to storage that are near electricity output rates; thus the strategy is buy low and sell high. With most heat storage systems, there are separate capital costs associated with heat input, storage, and heat-to-electricity production.

Accumulators and some other heat storage technologies have very low costs for heat addition to storage. The profitable strategy may be to send steam to storage 6 hours per day when prices are the lowest and produce added electricity 18 hours per day to minimize the cost of the more expensive heat-to-electricity component of the storage system. For many existing reactors up to 20% of the steam would go to storage when low prices. The maximum power output would increase by less than 5% to avoid major upgrades of the turbine hall. When viewing the nuclear plant as a black box, the addition of storage would appear to have increased its “base-load” capacity by a few percent and dramatically increased the capability to rapidly go down and back up in power. Inside the plant the reactor is operating at full capacity.

Other technologies such as nuclear geothermal inject hot water underground and use a geothermal power system for electricity production. Because of the extremely low cost of storage, such systems may enable seasonal energy storage, provide assured generating capacity and provide the option for a strategic multi-year heat reserve—the low-carbon equivalent to a strategic oil reserve.

The business case is central. Five years ago coupling heat storage to a LWR reactor would not have been economic. The changes in the electricity markets indicate that such an option may now be economical in some markets. As the markets continue to change, the economic case improves.

There is a need for demonstration projects to address institutional issues, to provide technology demonstrations for the near-term options and collect sufficient information to determine the economics.

ACKNOWLEDGEMENTS

We would like to thank the U.S. Department of Energy, Idaho National Laboratory (INL) and Exelon Corporation for their support of the workshop.

Work supported through the INL National Universities Consortium (NUC) Program under DOE Idaho Operations Office Contract DE-AC07-05ID14517.

CANES PUBLICATIONS

Topical and progress reports are published under seven series:

Advances in Nuclear Energy Disciplines (ANED) Series
Advanced Nuclear Power Technology (ANP) Series
Nuclear Fuel Cycle Technology and Policy (NFC) Series
Nuclear Systems Enhanced Performance (NSP) Series
MIT Reactor Redesign (MITRR) Series
Nuclear Energy and Sustainability (NES) Series
Nuclear Space Applications (NSA) Series

Please visit our website (mit.edu/canes/) to view more publication lists.

- MIT-ANP-TR-170 C. W. Forsberg, et al. **Light Water Reactor Heat Storage for Peak Power and Increased Revenue: Focused Workshop on Near-Term Options** (July 2017)
- MIT-ANP-TR-169 J. Conway, N. Todreas, **Offshore Floating Nuclear Plant (OFNP): A** (July 2017)
- MIT-ANP-TR-168 G. N. Genzman, N. Todreas, R. Abeyaratne, and M. Dahleh, **Ship Collision and the Offshore Floating Nuclear Plant (OFNP): Analysis of Possible Threats and Security Measures** (September 2016)
- MIT-ANP-TR-167 K. Shirvan, G. Daines, K. P. So, A. Mieloszyk, Y. Sukjai, and Ju Li, **Silicon Carbide Performance as Cladding for Advanced Uranium and Thorium Fuels for Light Water Reactors**, (August 2016)
- MIT-ANP-TR-166 C. W. Forsberg, S. Lam, D. M. Carpenter, D. G. Whyte, R. Scarlat, C. Contescu, L. Wei, J. Stempien, and E. Blandford, **Tritium Control and Capture in Salt-Cooled Fission and Fusion Reactors: Status, Challenges and Path Forward** (May 2016)
- MIT-ANP-TR-165 C. Forsberg, D. Carpenter, D. Whyte, R. Scarlat, and L. Wei, **Tritium Control and Capture in Salt-Cooled Fission and Fusion Reactors: Experiments, Models, and Benchmarking** (January 2016)
- MIT-ANP-TR-164 J. Zhang, J. Buongiorno, M.W. Golay, N.E. Todreas, **Safety Analysis of OFNP-300 and OFNP-1100 (for design basis events)** (November 2015).
- MIT-ANP-TR-163 J. Stempien, R. Ballinger, C. Forsberg, M. Kazimi, **Tritium Transport, Corrosion, and Fuel Performance Modeling in the Fluoride Salt-Cooled High-Temperature Reactor (FHR)** (September 2015).
- MIT-ANP-TR-162 C. Forsberg, **Strategies for a Low-Carbon Electricity Grid with Full use of Nuclear, Wind and Solar Capacity to Minimize Total Costs** (August 2015).
- MIT-ANP-TR-161 A. Briccetti, J. Buongiorno, M.W. Golay, N.E. Todreas, **An Analysis of the Spreading of Radionuclides from a Vent of an Offshore Floating Nuclear Power Plant** (2015).
- MIT-ANP-TR-160 J. Jurewicz, J. Buongiorno, M.W. Golay, N.E. Todreas, **Design and Construction of an Offshore Floating Nuclear Power Plant** (June 2015).

MIT-ANP-TR-159 Matthew Brian Strother, J. Buongiorno, M.W. Golay, N.E. Todreas, **Hydrodynamic Analysis of the Offshore Floating Nuclear Power Plant** (2015).

MIT-ANP-TR-158 Jacob DeWitte, N.E. Todreas, R. Ballinger, **Maximizing Nuclear Power Plant Performance via Mega-Uprates and Subsequent License Renewal** (January 2015).

MIT-ANP-TR-157 Charles Forsberg, Lin-Wen Hu, Per Peterson and Kumar Sridharan, **Fluoride-Salt-Cooled High-Temperature Reactor (FHR) for Power and Process Heat** (December 2014).

MIT-ANP-TR-156 Nghia T. Nguyen and Neil E. Todreas, **An Inverted Pressurized Water Reactor Design With Twisted-Tape Swirl** (June 2014).

MIT-ANP-TR-155 K. Shirvan, R. Ballinger, J. Buongiorno, C Forsberg, M.S. Kazimi, N.E. Todreas, **Advanced Offshore Seabed Reactors** (April 2014).

MIT-ANP-TR-154 C. Forsberg, L-W. Hu, J. Richard, R. Romatoski, B. Forget, J. Stempien, R. Ballinger, **Fluoride-Salt-Cooled High-Temperature Test Reactor (FHTR): Goals, Options, Ownership, Requirements, Design, Licensing, and Support Facilities** (December 2014).

MIT-ANP-TR-153 C. Forsberg, D. Curtis, J. Stempien, R. MacDonald, P. Peterson, **Fluoride-Salt-Cooled High-Temperature Reactor (FHR) Commercial Basis and Commercialization Strategy. A Fluoride-Salt-Cooled High-Temperature Reactor (FHR) with a Nuclear Air-Brayton Combine Cycle (NACC) and Firebrick Resistance-Heated Energy Storage (FIRES)** (December 2014).

MIT-ANP-TR-152 A. Briccetti, J. Buongiorno, M. Golay, N. Todreas, **Siting of an Offshore Floating Nuclear Power Plant** (May 2014).

MIT-ANP-TR-151 M.J. Minck, and C. Forsberg, **Preventing Fuel Failure for a Beyond Design Basis Accident in a Fluoride Salt Cooled High Temperature Reactor** (January 2014).

MIT-ANP-TR-150 Y-H. Lee, T. McKrell, and M.S. Kazimi, **Safety of Light Water Reactor Fuel with Silicon Carbide Cladding** (January 2014).

MIT-ANP-TR-149 Y. Sukjai, E. Pilat, K. Shirvan, and M.S. Kazimi, **Silicon Carbide Performance as Cladding for Advanced Uranium and Thorium Fuels for Light Water Reactors** (January 2014).

MIT-ANP-TR-148 Bloore DA, Pilat EE, Kazimi MS. **Reactor Physics Assessment of Thick Silicon Carbide Clad PWR Fuels** (July 2013).

MIT-ANP-TR-147 Forsberg C, Hu L-wen, Peterson PF, Sridharan K. **Fluoride-Salt-Cooled High-Temperature Reactors (FHRs) for Base-Load and Peak Electricity, Grid Stabilization, and Process Heat** (June 2013).

MIT-ANP-TR-146 Tingzhou Fei, E. Shwageraus, and M. J. Driscoll, **Innovative Design of Uranium Startup Fast Reactors** (November 2012).

MIT-ANP-TR-145 K. Shirvan and M.S. Kazimi, **Development of Optimized Core Design and Analysis Methods for High Power Density BWRs** (November 2012).

MIT-ANP-TR-144 G.L. DeWitt, T. McKrell, L-W Hu, and J. Buongiorno, **Investigation of Downward Facing Critical Heat Flux with Water-Based Nanofluids for In-Vessel Retention Applications** (July 2012).

MIT-ANP-TR-143 C. Forsberg, L-Wen Hu, P.F. Peterson, and T. Allen, **Fluoride-Salt-Cooled High-Temperature Reactors (FHRs) For Power and Process Heat. Advanced Nuclear Power Program** (January 2012).

MIT-ANP-TR-142 J. DeWitte and N.E. Todreas, **Reactor Protection System Design Alternatives for Sodium Fast Reactors** (September 2011).

MIT-ANP-TR-141 G. Lenci, N.E. Todreas, M.J. Driscoll and M. Cumo, **Alternatives for Sodium Fast Reactor Cost-Effective Design Improvements** (September 2011).

MIT-ANP-TR-140 M.R. Denman, N.E. Todreas and M.J. Driscoll, **Probabilistic Transient Analysis of Fuel Choices for Sodium Fast Reactors** (September 2011).

MIT-ANP-TR-139 R.P. Arnold, T. McKrell, and M.S. Kazimi, **Vented Silicon Carbide Oxidation in High Temperature Steam** (September 2011).

MIT-ANP-TR-138 F. Vitillo, N.E. Todreas, M.J. Driscoll, **Vented Inverted Fuel Assembly Design for an SFR** (June 2011).

MIT-ANP-TR-137 B. Truong, L-W Hu, J. Buongiorno, T. McKrell, **Effects of Surface Parameters on Boiling Heat Transfer Phenomena** (June 2011).

MIT-ANP-TR-136 J. Dobisesky, E.E. Pilat, and M. S. Kazimi, **Reactor Physics Considerations for Implementing Silicon Carbide Cladding into a PWR Environment** (June 2011).

MIT-ANP-TR-135 J.D. Stempien, D. Carpenter, G. Kohse, and M. S. Kazimi, **Behavior of Triplex Silicon Carbide Fuel Cladding Designs Tested Under Simulated PWR Conditions** (June 2011)

MIT-ANP-PR-134 M.S. Kazimi, J. Dobisesky, D. Carpenter, J. Richards, E. E. Pilat, and E. Shwageraus, **Feasibility and Economic Benefits of PWR Cores with Silicon Carbide Cladding** (April 2011).

MIT-ANP-TR-133 R.C. Petroski and B Forget, **General Analysis of Breed-and-Burn Reactors and Limited-Separations Fuel Cycles** (February 2011).

MIT-ANP-TR-132 D. M. Carpenter and M. S. Kazimi, **An Assessment of Silicon Carbide as a Cladding Material for Light Water Reactors** (November 2010)

MIT-ANP-TR-131 Michael P. Short and Ronald G. Ballinger, **Design of a Functionally Graded Composite for Service in High Temperature Lead and Lead-Bismuth Cooled Nuclear Reactors** (October 2010)

MIT-ANP-TR-130 Yu-Chih Ko and Mujid S. Kazimi, **Conceptual Design of an Annular-Fueled Superheat Boiling Water Reactor** (October 2010)

MIT-ANP-TR-129 Koroush Shirvan and Mujid S. Kazimi, **The Design of a Compact, Integral, Medium-Sized PWR: The CIRIS** (May 2010)

MIT-ANP-TR-128 Tingzhou Fei and Michael Golay, **Use of Response Surface for Evaluation of Functional Failure of Passive Safety System** (March 2010)

MIT-ANP-TR-127 Rui Hu and Mujid S. Kazimi, **Stability Analysis of the Boiling Water Reactor: Methods and Advanced Designs** (March 2010).

MIT-ANP-TR-126 Paolo Ferroni and Neil E. Todreas, **An Inverted Hydride-Fueled Pressurized Water Reactor Concept** (October 2009).

MIT-ANP-TR-125 M.S. Kazimi, P. Hejzlar, Y. Shatilla, Bo Feng, Yu-Chih Ko, E. Pilat, K. Shirvan, J. Whitman, and A. Hamed, **A High Efficiency and Environmentally Friendly Nuclear Reactor (HEER) for Electricity and Hydrogen** (October 2009).

MIT-ANP-TR-124 Joshua J. Whitman and Mujid S. Kazimi, **Thermal Hydraulic Design Of A Salt-Cooled Highly Efficient Environmentally Friendly Reactor** (August 2009).

Executive Summary
Light Water Reactor Heat Storage for Peak Power and Increased Revenue:
Workshop on Options

June 27-28, 2017, Massachusetts Institute of Technology, Cambridge, Massachusetts
Charles Forsberg

INTRODUCTION

Worldwide electricity markets are changing due to a combination of region-specific market forces and country-specific policy shifts. In the U.S. market changes are driven by a combination of low-cost natural gas and the addition of intermittent and often subsidized renewable generators (wind and solar). This has reduced the demand for base-load electricity. At the same time there is an increased demand for dispatchable electricity—a market currently served in the United States primarily by natural gas turbines, some pumped hydroelectricity and to a very limited extent batteries. These changes may be challenging the economics of nuclear power today but may create new opportunities for existing and new-build nuclear energy systems in the future. Heat storage may be able to help sustain base-load reactor operation with variable electricity to the grid.

To address these nuclear energy challenges the Massachusetts Institute of Technology (MIT), Idaho National Laboratory (INL), and Exelon conducted a workshop on *Light Water Reactor (LWR) Heat Storage for Peak Power and Increased Revenue* on June 27-28, 2017 at MIT. A workshop charter was prepared for participants.

The workshop goals are to define and understand the market, regulatory, and technical options for coupling heat storage to existing and future LWRs with recommendations for the path forward to improve LWR economics. The emphasis is using the stored heat produced at times of low electricity prices for electricity production at times of high electricity prices with a secondary consideration for off-site heat sales (different regulatory constraints and economics). The options to be discussed are primarily associated with those that divert steam from the LWR to storage while maintaining the main turbine on line at part load to allow rapid return to full power providing variable electricity to the grid. The power plant goal is increased annual revenue with a reactor that operates at full load and does not “see” the variable electricity output from the plant site. The electricity

system goal is low-cost low-carbon dispatchable electricity.

This report summarizes the workshop. The origins of the workshop are built upon several technological observations. Nuclear reactors produce heat that is then converted into electricity whereas wind and solar photovoltaic produce electricity. Heat storage is 10 to 40 times less expensive than storing work; that is, storing electricity using technologies such as hydro pumped storage and batteries. This reflects the thermodynamic differences between heat and work, not the status of current technologies. Heat storage is therefore the alternative energy storage strategy for a low-carbon electricity grid—one suitable to coupling to LWRs.

ELECTRICITY MARKETS

What Has Changed

Mankind has had the same energy policies for 300,000 years—meet variable energy demands by throwing a little more carbon on the fire. While the technology has changed from the cooking fire to the gas turbine, the economics have not. The cost of the cooking fire (stone or brick) and the gas turbine are low. Most of the labor and capital resources are gathering the fuel (wood, natural gas, etc.) and bringing it to the fire. These are low-capital-cost high-operating-cost technologies. As a consequence it is economical to produce variable energy to match variable energy needs by operating the fire at part load.

In a low-carbon world the energy sources are nuclear, wind, and solar. These technologies have high capital costs and low operating costs. If these energy production facilities are operated at half capacity, the bus-bar cost of electricity approximately doubles. Because energy is about 8% of the global economic output, increases in energy costs have large impacts on U.S. and global standards of living. Equally important, the uneven distribution of renewables has serious geopolitical implications.

The differences between fossil energy technologies (low-capital cost, high-operating cost) and low-carbon technologies (high-capital cost, low-operating cost) has major impacts on electricity prices as seen in deregulated electricity markets. In these markets electricity generators bid a day ahead to provide electricity to the grid. The grid operator accepts the lowest bids to meet electricity demands. All of the winning bids are paid the electricity price (\$/MWh) of the highest-priced winning electricity bid required to meet the electricity demand for that hour. Nuclear, wind and solar bid their marginal operating costs which are near zero. Fossil plants bid their marginal costs that are close to the cost of fossil fuels that they burn.

In a market with nuclear and fossil plants, the fossil plants set the hourly price of electricity. If one adds large quantities of solar or wind, their low operating costs set market prices at times of high wind or solar production. Figure ES.1 shows the impact of solar additions between 2012 and 2017 on California electric prices on a spring day with high solar input and low electricity demand. Electricity prices collapse at times of high solar production. In this specific example the prices have gone negative because of government subsidies that allow the solar producer to pay the grid to take electricity to collect production tax credits. The price increases as the sun goes down because of lower solar electricity production and peak demand occurs in the early evening.



Fig. ES.1. Impact of Added Solar on California Electricity Prices for Second Sunday in April: 2012 and 2017

The same effect occurs with wind as shown in Fig. ES.2 in Iowa. Wind has a multiday cycle on the Great Plains and thus the daily prices of electricity vary.

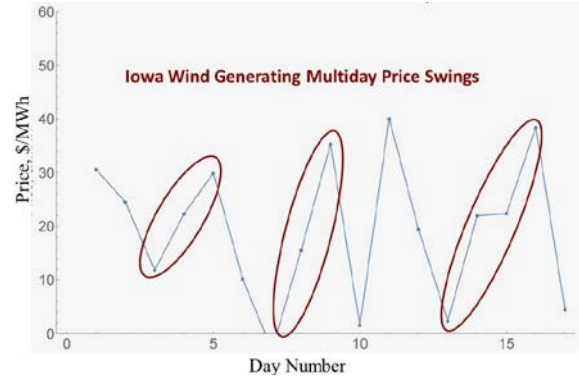

Fig. ES.2. Impact of Wind on Daily West-Iowa Electricity Prices in April 6-22, 2014

All high-capital-cost low-operating-cost technologies will collapse the price of electricity at certain times if deployed on a sufficiently large scale. The value of the product goes down with increased deployment. This price collapse occurs as solar provides ~15% of total electricity demand, wind provides ~30% of total electricity demand or nuclear provides ~70% of total electricity demand when fossil fuels provide the remainder of the electricity. The low solar fraction reflects high output in the middle of the day whereas the high nuclear fraction reflects the base-load component of the electricity demand. Price collapse economically limits the deployment of all low-carbon technologies with deployment of any low-carbon technology making the other low-carbon technologies less economic—overlapping price collapse.

This market effect has two impacts. First, the deployment of these technologies favors deployment of low-capital-cost high-operating-cost fossil plants to provide electricity at other times when prices are higher. Second, this change in the market creates the economic incentive to deploy energy storage systems to consume low-price energy (raise its price) and provide energy at times of higher demand.

The storage times in a market with large quantities of solar generation (daily cycle) are different than the storage times in a market dominated by wind (multi-day cycle). The variation of electricity demand is different across the country with large differences due to different climates. One does not expect that there will be a “single” economically optimum storage solution. The optimal storage solution will vary with location.

Energy, Capacity and Auxiliary Service Markets

There are three electricity markets in which energy storage has the potential to increase revenue for the owner of an existing or new plant—each with different characteristics.

Energy markets. Energy markets pay per unit of electricity delivered to the grid. Figures ES.1 and ES.2 show the variation in prices in selected energy markets versus time that creates the fundamental economic case for all energy storage systems—store energy when prices are low to sell when prices are high.

The economics of storage depend upon two characteristics of energy markets. The first is how many cycles of energy storage are needed per year. If the number of cycles is doubled, energy storage costs are decreased by a factor of two. The other factor is the difference between the low and high prices.

On the production side, both of these factors strongly depend upon the scale of wind and solar deployment. The larger the deployment of these technologies, the stronger becomes the economic case for storage. On the demand side, there are daily, weekly, and seasonal variations in demand.

Capacity Markets. There are two strategies to assure sufficient generating capacity to meet demand; that is, to avoid blackouts. The first is to have no capacity market and allow energy prices to go to very high levels (\$1000s/MWh or more) at times of scarcity. Plants will be built whose revenue depends upon incomes during the sale of electricity for tens or hundreds of hours per year when prices are very high.

The second strategy is for the grid to have contracts for assured electricity supply even if multiday periods of low solar production, month-long period of low wind (such as last January in Europe) or extreme weather events (United States). Most electricity markets have capacity markets where the grid operator pays so many dollars per megawatt of assured capacity. In effect, the grid operator pays to lower the risks of blackouts because the high costs of such blackouts in terms of economics, public health risks (cold houses, summer heat exhaustion, etc.) and social disruption.

Historically capacity markets were not needed or the payments were very low because the electricity was generated by nuclear and fossil units. These are dispatchable electricity sources. The addition of

wind and solar have increased the use of capacity markets because these energy sources can't assure production of electricity given their intermittency.

Most storage technologies can't enter the capacity markets because their storage times are too short. However some thermal energy storage technologies have low-cost storage that may enable them to obtain payments in the capacity markets for assured capacity. Storage system cost can be divided into two major components: (1) the cost of the system that converts stored energy to electricity (\$/MWe) and (2) the cost of storing the energy (\$/MWh). In a pumped hydro facility the first cost is associated with the pumps, turbines and generators while the second cost is associated with building the two water reservoirs. If a storage system is to compete in the capacity market it needs very low energy storage costs (\$/MWh) to enable storing large quantities of energy for long time periods. In some heat storage systems (sensible heat, hot rock and geothermal) this cost is very low and thus may enable such storage technologies to participate in capacity markets.

Auxiliary Services Market. This refers to other electricity grid services such as frequency control, black start (start after power outage) and reserves for rapid response grid emergencies such as another electrical generator failing. Many of the thermal storage technologies associated with LWRs have some capabilities to provide these services as described below. However, this is not a major source of revenue for power generation.

HEAT STORAGE TECHNOLOGY OPTIONS

Reactor Constraints

Economic and technical considerations impose constraints on heat storage systems coupled to LWRs.

Constant full reactor output. To maximize economics and minimize operational challenges, the high-capital-cost low-operating-cost reactor should be operated at full power. Steam output from the reactor is envisioned to be divided between the main turbine and the storage system.

Minimum electricity to the grid. For the power plant to maintain its capability to rapidly send 100% of its rated capacity to the grid, a minimum steam flow to the turbine is required to allow rapid return to full power by shutting off steam going to storage. This implies the minimum power to the grid is near 30%. However, many existing plants have instabilities in the Balance of Plant (BOP) that limit the minimum power to the grid to about 60% to 70%—at which time 30% to 40% of the steam could go to the storage system. With new plants or changes in existing plants, the minimum power level can be much lower. If the main turbine is shut down, it can be hours before it can be put back on line.

There are several implications of these ground rules. First, the reactor can respond to rapid changes in electricity demand to maximize revenue—as evident in Fig. ES.1. Second, the plant can provide some auxiliary services. There are costs. The efficiency of the main steam plant goes down as the load goes down (Fig. ES.3).

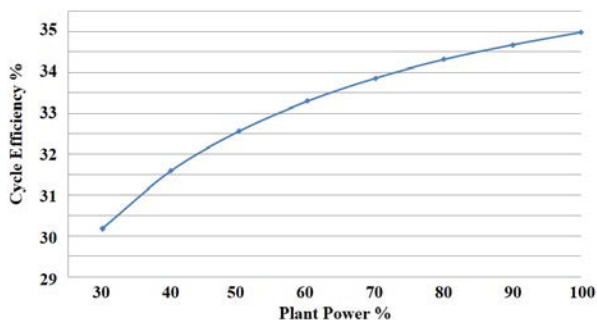

Fig. ES.3. Typical 1200 MWe Pressurized Water Reactor Plant Cycle Efficiency (%) vs. Power Level (%). Courtesy of Westinghouse Corporation

Maximum electricity to the grid. This is equal to the base-load capacity of the power plant plus the power output from the energy storage system. For some technologies this output can be 2 to 3 times the base-load electricity output.

The other consideration is how to couple the LWR to the heat storage system. There are two broad sets of options with many variants and some combination systems. In Europe and Asia a number of LWRs produce steam for electricity and off-site customers so there is considerable real-world experience in nuclear plants producing electricity and exporting heat.

Stand-alone Storage Systems. With this option steam is diverted before the high-temperature turbine and sent to the storage system that has its own power generation system. The condensate returns to the reactor turbine condenser. When steam is diverted before the high-temperature turbine, it is at constant pressure and temperature. Steam diverted from other locations in the turbine hall has variable temperature and pressure depending upon plant operations. High-temperature steam extraction is generally more desirable when there is a need to transport steam over longer distances to an energy storage system.

There is relevant experience in the United States about what is required to do this. About a decade ago the Fort Calhoun Nuclear Power Plant did detailed engineering and cost studies, including discussions with the Nuclear Regulatory Commission, on diverting some of its steam to a reboiler with return of condensate to the reactor turbine condenser and sending reboiler steam to a nearby Cargill industrial plant. The conclusion is that this was practical, economic, and had no significant impact on safety. The project did not go forward for other reasons.

Integrated Storage Systems. With this option steam is diverted to storage at times of low demand and heat is sent back to the turbine hall at times of high demand to produce added electricity. The main turbine is used to produce the added electricity.

This option has two advantages. First, the incremental capital cost to the power cycle for added electricity output is significantly lower than with a stand-alone power system coupled to heat storage. Second, the main turbine is always operating. That enables fast response to changing electricity demand when stored heat is returned to the turbine hall. There are disadvantages. There are practical limits on the peak power output relative to base-load power—perhaps 20% to 25% higher. The turbine efficiency varies with load so that efficiency will be lower at either base-load or the peak power level. Last, this option is easy to design into a new plant but the ability to economically modify an existing plant depends upon the specific plant.

The characteristics of LWR steam cycles provide multiple options on how to integrate heat storage into the power cycle. Up to a third of the steam from the reactor is diverted from the turbines to feed-water heaters to improve plant efficiency.

The different feed-water heaters operate at different temperatures. Stored heat can be sent back as steam to the main turbine or to the feed-water heaters to allow more primary steam to the turbines.

The workshop focused on LWRs because they are the most common reactor type worldwide. The same storage technologies apply to all other water-cooled reactors with steam cycles and with some constraints to other reactors with steam cycles.

Thermal Storage Options

Six classes of storage options that couple to LWRs were examined where steam is the input to the storage system. For some options, there is the choice to get steam from the storage system that could be fed back to the main reactor turbine if that turbine was oversized.

Steam Accumulators. A steam accumulator is a pressure vessel nearly full of water that is heated to its saturation temperature by steam injection. The heat is stored as high-temperature high-pressure water. When steam is needed, valves open and some of the water is flashed to steam that is sent to a turbine producing electricity while the remainder of the water decreases in temperature.

Steam accumulators have been used for energy storage and pressure buffers in steam plants for over a century and are coupled to several solar thermal plants as a mechanism of heat storage to enable variable electricity production. The earliest large-scale steam accumulator for variable electricity production was built in Berlin in the 1920s, charged using steam from a fossil power plant, and had a peak output of 50 MWe. Steam accumulators are capable of rapid charge and discharge cycles. While there have been only limited studies of steam accumulators coupled to nuclear reactors, the technology could be deployed today. The cost of the high-pressure storage tanks probably limits these systems for hourly to daily energy storage where there are many cycles of storage per year to cover capital costs.

Sensible Heat Fluid Systems. Sensible heat storage involves heating a second fluid with steam, storing that second hot fluid at atmospheric pressure,

and using that fluid later to provide the heat to produce steam to then produce electricity. This heat storage technology is used with solar thermal power systems at temperatures near those of LWRs. A range of fluids have been used in these systems. Studies at North Carolina State University and Westinghouse indicate that heat transfer oils are likely to be the preferred heat transfer fluid when coupling sensible heat storage to an LWR.

There are two physical storage configurations: two-tank and thermocline systems. In a two-tank system, one tank will hold cold fluid and one will hold hot fluid, with the ratio of fill levels in the tanks indicating the state of charge. In a thermocline system during charging, hot fluid is injected at the top of the tank while cold fluid is removed from the bottom. To remove heat, the process is reversed. In both cases, one heat exchanger is used to heat the fluid with steam during charging and one is used to cool the fluid to produce steam or hot water when discharging.

In some solar thermal power systems, oil is used as the heat transfer fluid in the solar collector. Solar thermal two-tank sensible heat storage has been demonstrated at the 100 MWh scale, and the thermocline type has been demonstrated at the 1 MWh scale.

Westinghouse has begun development of a sensible heat storage system for LWRs (Fig. ES.4) where each storage module stores sufficient heat to generate a MWh of electricity.

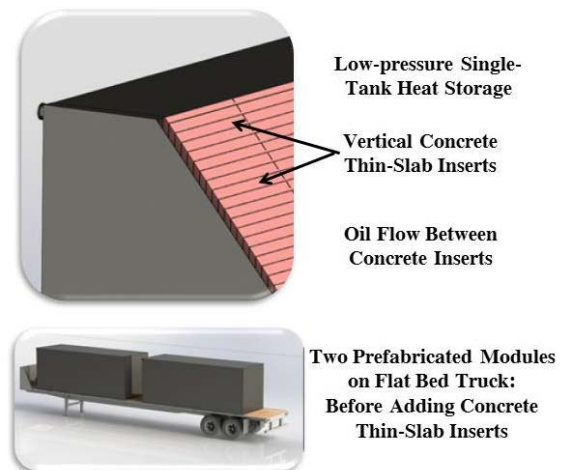

Fig. ES.4. Westinghouse Thermal Heat Storage Module for 1 MWh of Electricity Storage

Steam heats low-pressure oil that then transfers its heat to a heat storage module. In this system the storage tanks have vertical concrete plates as the primary heat storage media rather than oil because concrete is a much less expensive heat storage media and can be produced locally. The hot oil flows through narrow channels between slabs of concrete. To recover the heat, the direction of oil flow is reversed. The hot oil would be used to generate steam that is sent to (1) the main reactor turbine, (2) a partial replacement for steam to feed-water heaters, or (3) a separate power system. Alternatively it could be used to produce hot water for local needs.

Cryogenic Air Systems. A cryogenic air energy storage system stores energy by liquefying air. A less tightly coupled cryogenic system would use electricity to drive the chilling process; the option exists to more tightly integrate the chilling process with the nuclear plant and use steam turbines. The liquefied air can be stored in facilities similar to those used to store liquefied natural gas (LNG). The energy storage capacity of the liquid air reservoir can be enhanced through the integration of a sensible heat storage system. To produce electricity, the liquid air is compressed, heated using low-temperature heat (cooling water) from the power plant and then heated with steam from the NPP secondary side and sent through a gas turbine before being exhausted to the atmosphere.

This technology can be coupled to any heat source. A pilot plant is now operating in the United Kingdom (Fig. ES.5). The estimated round-trip efficiency for this technology coupled to a LWR is over 70%.



Fig. ES.5. Highview 5MW/15MWh Commercial Cryogenic Demonstration plant in Manchester Integrated with Viridor Biogas Power Plant

Packed-bed Thermal Energy Storage. A packed-bed thermal energy storage system (Fig. ES.6)

consists of a pressure vessel filled with solid pebbles with a steam valve at the top and water outlet at the bottom. Heat is stored as sensible heat in the pebbles. To charge the system, steam is injected. The steam condenses as the cold pebbles are heated and water exits from the bottom of the vessel. At the end of the charging cycle all pebbles are hot and there is hot water filling the voids at the bottom of the vessel. To discharge the system, water is injected into the bottom of the vessel and steam is produced by the hot pebbles.

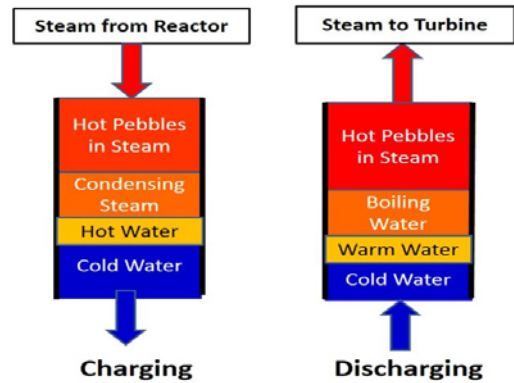

Fig. ES.6. Packed Bed Heat Storage System

In theory this should be the most efficient heat storage system in terms of round-trip efficiency. The heat storage system directly uses steam with no temperature losses in a heat exchanger in either direction—steam in and steam out. Packed beds are more thermodynamically efficient than other storage systems because they operate in a counter-current mode—the hottest steam sees the hottest pebbles. A sharp hot-to-cold front with small dimensions is only possible with a saturated-steam input where the very high heat transfer of condensation and boiling occurs over a very small zone in the bed. This is not true for superheated steam and other systems where the length of the heat transfer zone becomes excessively long relative to practical dimensions of real systems. The window of design options for packed-bed systems, including the range of suitable pebble materials and sizes and the impact of pebble choice on dynamic performance, is only partly explored. There has been limited experimental work.

Hot Rock Storage. A hot rock energy storage system (Fig. ES.7) is similar in concept to a packed

bed energy storage system except it operates at atmospheric pressure with air. A volume of crushed rock with air ducts at the top and bottom is created. To charge the system, air is heated using a steam-to-air heat exchanger delivering heat from the reactor, then the air is circulated through the crushed rock heating the rock. To discharge the system, the airflow is reversed, and cold air is circulated into the crushed rock at the bottom. This discharged hot air can be used to (1) produce steam for electricity or industry or (2) hot air for collocated industrial furnaces to reduce natural gas consumption.

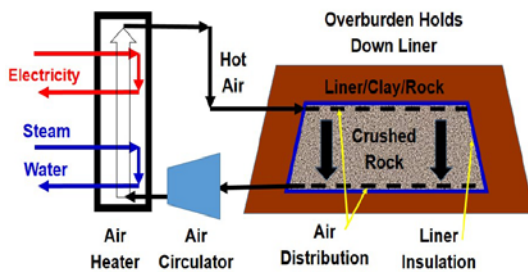

Fig. ES.7. Schematic of Hot-Rock Heat Storage in Charging Mode.

Heat storage systems are only charged at times of very low electricity prices. There is the option with this system to first heat the air with a steam-air heat exchanger and then further heat the air with electric resistance heating. This can substantially boost rock temperatures and the efficiency of converting hot air back to electricity.

A variant of large hot-rock systems is under development by the shale oil industry (Red Leaf Inc.) to produce oil. In that system the rock is crushed oil shale and heated hot gases are circulated through the rock to decompose solid kerogen into liquid and gaseous hydrocarbon fuels. For that system the rock pile will be about 30 meters high.

Only limited analytical studies have been done on hot rock storage. It potentially has very low incremental heat storage costs (crushed rock) that may enable its use to provide economic hourly to weekly heat storage.

Geothermal Heat Storage Systems. Nuclear geothermal heat storage systems combine the features of an enhanced geothermal energy facility with thermal energy storage. Thermal energy is

stored by injecting hot water heated by steam from the reactor into the underground reservoir; energy is discharged by pumping hot water back to the surface for electricity production in a conventional geothermal plant. Limited studies have been completed but there is currently no development program or field experiments. Significant research, development and demonstration would be required before deployment of this storage technology.

This heat storage technology has different characteristics than the other heat storage options.

- *Seasonal heat storage.* It is the only heat storage option that is a candidate for seasonal energy storage because of the very low cost of the storage media—rock. This would enable hourly to seasonal thermal energy storage.
- *Large minimum size.* The minimum size system is about 0.1 GW-year. One can't insulate rock underground so there are thermal heat losses by heat conduction to nearby rock. However, the heat storage capacity increases by the cube of system dimensions while heat losses increase by the square of system dimensions. As the system becomes larger, heat losses become proportionally smaller.
- *Strategic heat reserve.* This system has the potential for very low-cost multiyear storage, creating the option of a strategic energy storage reserve for a low-carbon society. It would replace the strategic oil reserve and other energy storage technologies based on fossil fuels.
- *Geographical dependence.* The viability of this system depends upon local geology whereas the other heat storage systems are engineered systems that can be built almost anywhere.

Recent work at Lawrence Livermore National Laboratory has extended the concept of geothermal heat storage to include gas storage for energy input as (1) heat and (2) electricity to compressed gases with energy output of heat and compressed gases—both that can be converted to electricity. By adjusting pressures underground, the hot water can be sent quickly to the power cycle for rapid response to variable electricity demand.

Matching Storage Options to Markets

Each heat storage technology has different characteristics such as rate of charging, round-trip efficiency, rate of discharge, cost to input energy into the system (\$/MWh), cost of storage (\$/MWh) and cost of converting heat to electricity (\$/MWe). As a consequence, the preferred option will depend upon the electricity market. The preferred heat storage system in a grid with large solar capacity and the need for daily energy storage will likely be different than a system with excess wind capacity and multiday cycles of low and high-priced electricity.

Heat storage cost structures are different from storage technologies such as batteries and most other electricity storage technologies. Batteries and pumped hydro storage are expensive and for engineering reasons have peak electricity input rates into storage that are near peak rates of electricity output. The strategy is to buy low-price electricity and sell only when electricity prices are very high (Fig. ES.8).

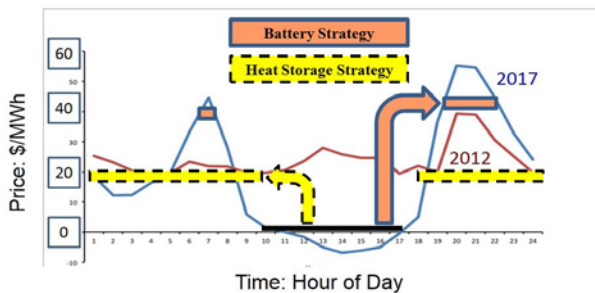

Fig. ES.8. Alternative Buy and Sell Strategies for Batteries and Nuclear Heat Storage in California Electricity Market Shown in Fig. ES.1

In heat storage systems the heat-to-storage input, storage, and heat-to-electricity output are separately sized. Accumulators and some other heat storage technologies have very low costs for heat addition to storage. Much of the cost is with the cost of converting heat-to-electricity that depends whether there is a stand-alone power system or an incremental increase in the nuclear steam turbine-generator set. In a market with large-scale solar the profitable strategy may be to send steam to storage 7 hours per day when prices are low and produce added electricity 17 hours per day. The storage system would have very high steam input rates into

storage (low-cost part of system) and smaller peak electricity production rates (higher-cost part of system). When viewing the nuclear plant as a black box, the addition of storage would appear to have increased its “base-load” capacity with the capability to ramp down power output at times of low electricity prices. Inside the plant the reactor is operating at full capacity. For many existing reactors it may be possible to send up to 20% of steam output to storage when prices are low with little or no upgrade of the turbine-generator to produce added electricity when prices are higher.

Several of the technologies (sensible heat, hot rock and geological) may be able to participate in capacity markets with assured capability to produce electricity when needed because of their low incremental cost of heat storage (\$/MWh). The ability of the other technologies to participate in electricity capacity markets will depend upon how capacity markets are defined—the length of time that electricity must be delivered. This is in contrast to almost all other storage technologies (batteries, most but not all pumped hydro) where the incremental energy storage costs (\$/MWh) are too large for this to be viable.

None of these storage technologies has yet been coupled to a nuclear reactor for heat storage. Accumulators and sensible heat systems have been deployed with solar thermal power systems. The steam accumulator technology is deployable today followed by the sensible heat storage technologies and cryogenic heat storage. The other technologies require added research, development, and demonstration.

REGULATORY AND MARKET RULES

Nuclear Regulatory Commission

No heat storage system has been coupled to a nuclear reactor in the United States. However, a decade ago the Fort Calhoun Nuclear Power Plant investigated selling large quantities of steam to Cargill for corn milling and ethanol production. This included detailed engineering studies, cost evaluations and discussions with the Nuclear Regulatory Commission on what was required to extract steam before the high pressure turbine and sell heat to an industrial facility. The project was not implemented but went far enough to provide

credible information on what is required to divert steam from a nuclear power plant and what is required for coupling heat storage to a PWR in the U.S. utility environment. No major problems were identified. Several utilities elsewhere in the world sell steam to local customers.

Market Rules

The market rules are in transition and changes may be required for large-scale heat storage. Utility experience is that changes in market rules can be made as new technologies are introduced; but, it will take time to make the required changes. These rules are partly set by legislation, the Federal Energy Regulatory Commission (United States) and state Public Service Commissions (state governments).

Market rules were originally developed for an electricity grid with nuclear plants with low operating costs and fossil plants with high operating costs. We are now in a transition from low-capital-cost high-operating-cost fossil-fuel technologies to high-capital-cost low-operating-cost technologies (nuclear, wind, and solar). Wind and solar result in large quantities of non-dispatchable electricity. This changes the nature of the electricity supply—including incentives for a larger capacity market. As a consequence, the rule sets are in a state of flux as regulators change rules to adjust to these changes.

The regulatory challenge with nuclear heat storage is that one is adding multiple gigawatt energy storage systems. In this context it is similar to the large hydro pumped storage facilities. In the U.S. utility environment there are several pumped storage facilities in deregulated markets but these are few in number and no new such facilities have been built in many decades. The addition of such a technology may result in rule modifications—particularly those associated with market power.

Equally important are technology-neutral market rules (including any subsidies) for storage technologies to find minimum-cost solutions to society.

COMMERCIALIZATION

Commercialization requires a strong business case, near-commercial technology and appropriate institutional structures.

The business case is central but there are caveats. First, the business case for large-scale heat

storage did not exist five years ago—it only appeared with the large-scale deployment of wind and solar that drives wholesale electricity prices to very low levels at times of large wind or solar electricity production. Second, the electricity market and the market rules are changing. These changes include the development of capacity markets that are accessible by some of the heat storage technologies but not by other storage technologies. Third, the economics are strongly dependent upon location

A strong case exists that the economics are much better than batteries and other electricity storage options available to the utilities—the longer-term competition. However, the competition today in the United States is low-price natural gas—except where natural gas supplies are limited by legal constraints or pipeline capacity. Proposals by companies such as Shell, Exxon, and BP for a carbon tax would dramatically improve the economics of these storage systems.

The lowest-cost options are likely to be options where stored heat goes back to the plant feed-water system or the turbine—minimizing storage system costs driven by dollars per kWe capacity. Steam is sent to storage at a very high rate (Fig. ES.8). Heat from storage is sent back at a quarter to half the charging rate to minimize investment in heat-to-electricity generating capacity. Heat storage built into an existing reactor where minor modifications allow larger power output of the main turbine-generator set (case by case evaluation) or a new reactor will have lower costs than a stand-alone heat storage and power generation system added to a reactor. Because the cost structure of LWR thermal storage is different than batteries or pumped hydro, the operating strategies may be very different to maximize return on investment.

The economics are sensitive to the number of storage cycles per year—doubling the number of cycles per year cuts costs in half if everything else is held constant. That implies that the economics rapidly improve with increased deployment of wind and solar that result in more periods of very low electricity prices.

Heat storage has implications beyond the electricity sector. The experience of the Fort Calhoun steam project shows that one of the barriers to exporting steam from nuclear reactors to industrial customers is assured steam delivery. If there is no storage, the industrial customer has to build into his plant the capability to withstand rapid

loss of heat supply if the reactor shuts down—either changes in process design or various rapid-start alternative steam supply systems. The development of heat storage systems minimizes the challenges of integrating nuclear steam production with industrial customers.

Heat storage systems for sending heat to industry have significantly lower costs than for the production of peak electricity. There is no need to convert the stored heat back to electricity. For many heat storage systems the heat-to-electricity component is the largest single capital cost.

Heat storage provides a way to transfer low-priced energy into storage for the later use by the industrial sector. In a reactor producing heat for industry and electricity for the grid, when electricity prices are high (1) the stored heat goes to industry and (2) the steam that would have gone to industry produces added electricity. This strategy minimizes the costs of heat storage (no heat-to-electricity system) while maximizing revenue.

The near-term heat storage options are at the point where a demonstration project is required. Such a demonstration will have several goals—some of them common to all heat storage technologies.

- *Institutional.* Previous experience with the NRC and markets (FERC and Public Service Commissions) indicate thermal storage at a reactor will couple with the electric grid. However, a demonstration project is required to demonstrate this and work through the permitting and regulatory process. In particular there is a need for timely NRC decision making. Storage should have little or impact on safety because the licensing basis accounts for failures in the power system.
- *Technology demonstration.* The chosen technology must be demonstrated at a scale sufficient to allow scale-up to full size in a utility environment. Given the characteristics of the technology, there is the option to demonstrate at scale.
- *Economics.* There are storage system economics but there are also the larger economics of the entire system. A demonstration project will provide the first numbers for both. This includes system upgrades such as transmission.

There are large incentives for government support of a government-private partnership for demonstration projects—particularly for the longer-term higher-technical-risk storage options such as nuclear geothermal heat storage. A strong public interest case exists. Energy is a major business and a major fraction of the economy. A break-through in lowering energy storage costs has massive economic implications and increases the long-term viability of an economic low-carbon electricity grid. While the technologies herein are for LWRs, many of these heat storage technologies apply to other nuclear reactor systems and solar thermal power systems.

OTHER CONSIDERATIONS

The successful development of large-scale heat storage coupled to nuclear power plants implies a new role for nuclear power—a base-load reactor that provides dispatchable electricity and steam to industry. It would be an enabling technology for an economic low-carbon grid where high-capital-cost low-operating-cost generating technologies operate in their most economic mode: full capacity

The main report provides added detail with a similar organization and references. It is organized as a technical report based on the output of the workshop, not as a literal hour-by-hour proceedings of the workshop. The appendixes include the workshop agenda, participant list, speaker bios and presentations.

ACKNOWLEDGMENTS

We would like to thank the U.S. Department of Energy, Idaho National Laboratory (INL) and Exelon Corporation for their support of the workshop. Work supported through the INL National University Consortium (NUC) Program under DOE Idaho Operations Office Contract DE-AC07-05ID14517.

Table of Contents

section	page
Abstract	3
Acknowledgements	5
CANES Publications	7
Executive Summary	11
Table of Contents	21
Figures	22
Tables	22
1. INTRODUCTION	23
2. ELECTRICITY MARKETS	25
2.1. What Has Changed	25
2.2. Energy, Capacity and Auxiliary Service Markets	27
3. HEAT STORAGE TECHNOLOGY OPTIONS	31
3.1. Reactor Constraints	31
3.2. Thermal Storage Options	34
3.2.1. Steam Accumulators (Direct hot water/steam storage)	34
3.2.2. Heat Storage (oil, salt, etc.) In Secondary Low-Pressure Media	37
3.2.3. Cryogenic Liquid Air Storage	40
3.2.4. Pressurized Counter-Current Condensing-Steam Solid Heat Storage	42
3.2.5. Atmospheric-Pressure Crushed-Rock Heat Storage	44
3.2.6. Nuclear Geothermal Heat Storage	46
3.3. Choice of Heat Storage Technology	50
4. REGULATORY AND MARKET RULES	53
4.1. Nuclear Regulatory Commission	53
4.2. Market Rules	53
5. COMMERCIALIZATION	54
5.1. Business Case	54
5.2. Hybrid Energy Systems	54
5.3. Next Step Forward	56
6. CONCLUSIONS	57
7. REFERENCES	58
Appendix A: Workshop Agenda	63
Appendix B: Workshop Participants and Speaker Biographies	66
Appendix C: Workshop Presentations	74

List of Figures

Fig. 2.1. Impact of Added Solar on California Electricity Prices for Second Sunday in April: 2012 and 2017 Hourly Wholesale Electricity Prices..... 16

Fig. 2.2. Impact of Wind on Daily West-Iowa Electricity Prices in April 6-22, 2014..... 16

Fig. 2.3. Capital Cost of Storage versus Utilization Rate for Existing and Optimistic Battery Costs..... 18

Fig. 2.4. Capital Cost of Storage versus Utilization Rate for Existing and Optimistic Battery Costs..... 19

Fig. 3.1. Typical 1200 MWe Pressurized Water Reactor Plant Cycle Efficiency vs. Power Level..... 21

Fig. 3.2. PWR Steam Plant with Selected Options for Steam Removal and Return to Turbine Plant..... 23

Fig. 3.3. Steam Accumulator Schematic..... 24

Fig. 3.4 Alternative Accumulator Options: Steel Vessel Charlottenburg Power Station Accumulators Built in Berlin in 1929, Proposed Pipe Rack Accumulator, and Prestress Concrete Vessel (PCV)..... 25

Fig. 3.5. Nuclear Thermal Energy Storage System (Charging Mode)..... 29

Fig. 3.6. Westinghouse Thermal Heat Storage Module for 1 MWh of Electricity Storage..... 30

Fig. 3.7. A schematic diagram of the cryogenic energy storage technology..... 31

Fig. 3.8. Highview 5MW/15MWh Commercial Demonstration plant in Manchester Integrated with Viridor Biogas Power Plant..... 32

Fig. 3.9. Operation of Pressurize Counter-Current Heat Storage..... 33

Fig. 3.10. Atmospheric Steam as Heat Transfer Fluid and an Alumina Packed Bed as Storage Media, X-ray and IR Images Every 10 Seconds..... 34

Fig. 3.11. Hot Rock Storage with Steam and Electric Input..... 35

Fig. 3.12. Nuclear Geothermal Heat Storage..... 36

Fig. 3.13. Fractional Energy Losses vs. Cycle for Three Reservoir Sizes..... 37

Fig. 3.14. An Earth Battery System with CO₂ is Shown..... 39

Fig. 3.15. Alternative Buy and Sell Strategies for Batteries (Sell Limited Hours) and Nuclear Heat Storage (Sell Many Hours) in California Electricity Market Shown in Fig. ES.1..... 42

List of Tables

Table 3.1. Solar Power Accumulators..... 26

Table 3.2. Relative Storage Option Characteristics..... 40

1. INTRODUCTION

Electricity markets are changing because of low-cost natural gas (United States and Canada) and the addition of intermittent renewable generators (wind and solar). This has reduced the demand for base-load electricity. At the same time there is an increased demand for dispatchable electricity—a market currently served in the United States primarily by natural gas turbines, to a smaller extent by pumped hydroelectricity and to a very limited extent by batteries. These changes are hurting the economics of nuclear power but may create new opportunities for nuclear energy systems with heat storage to enable base-load reactor operation with variable electricity to the grid.

To address these nuclear energy challenges the Massachusetts Institute of Technology (MIT), Idaho National Laboratory (INL), and Exelon conducted a workshop on *Light Water Reactor (LWR) Heat Storage for Peak Power and Increased Revenue* on June 27-28, 2017 at MIT. A workshop charter was prepared for participants.

The workshop goals are to define and understand the market, regulatory, and technical options for coupling heat storage to existing and future LWRs with recommendations for the path forward to improve LWR economics. The emphasis is using the stored heat produced at times of low electricity prices for electricity production at times of high electricity prices with a secondary consideration for off-site heat sales (different regulatory and technical constraints). The options to be discussed are primarily associated with those that divert steam from the LWR to storage while maintaining the main turbine on line at reduced load to allow rapid return to full power providing variable electricity to the grid. The power plant goal is increased annual revenue with a reactor that operates at full load and does not “see” the variable electricity output from the plant site. The electricity system goal is low-cost low-carbon dispatchable electricity.

This report summarizes that workshop. The origins of the workshop are built upon several technological observations. Nuclear reactors produce heat that is then converted into electricity whereas wind and solar photovoltaic produce electricity. Heat storage is 10 to 40 times less expensive than storing work; that is, storing electricity (Schmidt, 2017) using technologies such as hydro pumped storage and batteries. This reflects the thermodynamic differences between heat and work, not the relative status of current technologies. Heat storage is therefore the alternative energy storage strategy for a low-carbon electricity grid—one suitable to coupling to LWRs.

The report consolidates information from the workshop into an integral technical report—not a literal reporting of activities. The workshop agenda is in Appendix A, the list of workshop participants and bios of speakers is in appendix B. Workshop presentations are in Appendix C.

The report is organized into five chapters. Chapter 2 discusses the changes in the market that create the economic incentives to couple heat storage to reactors. Chapter 3 describes the different classes of heat storage options and the status of each technology. Chapter 4 discusses the regulatory and market rules from the perspective of nuclear safety regulations and electricity market rules. Market rules are changing with time. The addition of a technology that can act as a gigawatt battery or

provide assured capacity may result in changes to those rules. Chapter 5 discusses challenges for commercialization from the business case to demonstration.

2. ELECTRICITY MARKETS

2.1. What Has Changed

Mankind has had the same energy policies for 300,000 years—meet variable energy demands by throwing a little more carbon on the fire. While the technology has changed from the cooking fire to the gas turbine, the economics have not. The cost of the cooking fire (stone or brick) and the gas turbine are low. Most of the labor and capital resources are for gathering the fuel (wood, natural gas, etc.) and bringing it to the fire. These are low-capital-cost high-operating-cost technologies. As a consequence it is economical to produce variable energy to match variable energy needs by operating the fire at part load.

In a low-carbon world the energy sources are nuclear, wind, and solar. These technologies have high capital costs and low operating costs. If these energy production facilities are operated at half capacity, the production cost of energy approximately doubles. Because energy is about 8% of the global economic output, increases in energy costs have large impacts on U.S. and global standards of living. Equally important, the uneven distribution of renewables has serious geopolitical implications.

The differences between fossil energy technologies (low-capital cost, high-operating cost) and low-carbon technologies (high-capital cost, low-operating cost) has major impacts on electricity prices as seen in deregulated electricity markets. In these markets electricity generators bid a day ahead to provide electricity to the grid. The grid operator accepts the lowest bids to meet electricity demands. All of the winning bids are paid the electricity price (\$/MWh) of the highest-price winning electricity bid required to meet the electricity demand for that hour. Nuclear, wind and solar bid their marginal operating costs which are near zero. Fossil plants bid their marginal costs that are close to the cost of fossil fuels that they burn.

In a market with nuclear and fossil plants, the fossil plants set the hourly price of electricity. If one adds large quantities of solar or wind, their low operating costs set market prices at times of high wind or solar production. Figure 2.1 shows the impact of solar additions between 2012 and 2017 on California electric prices on a spring day with high solar input and low electricity demand. Electricity prices collapse at times of high solar production. In this specific example the prices have gone negative because of government subsidies that allow the solar producer to pay the grid to take electricity to collect production tax credits. The price rapidly increases as the sun goes down because of lower solar electricity production and because peak demand occurs in the early evening.

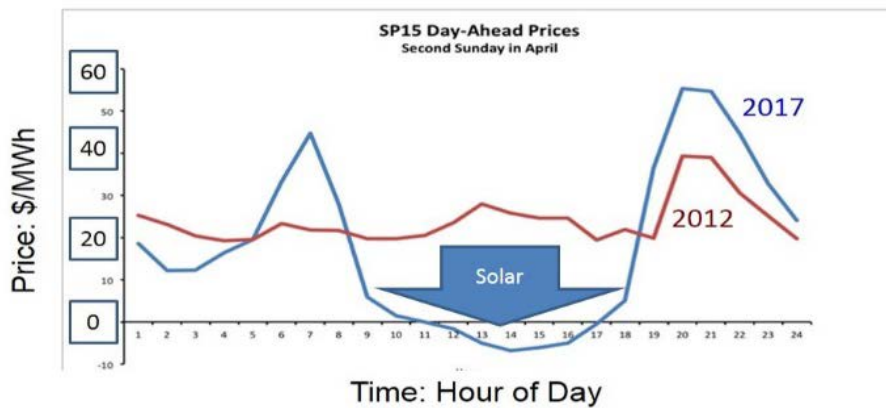

Fig. 2.1. Impact of Added Solar on California Electricity Prices for Second Sunday in April: 2012 and 2017 Hourly Wholesale Electricity Prices

The same effect occurs with wind as shown in Fig. 2.2 in Iowa. Wind has a multiday cycle on the Great Plains and thus the daily prices of electricity vary.

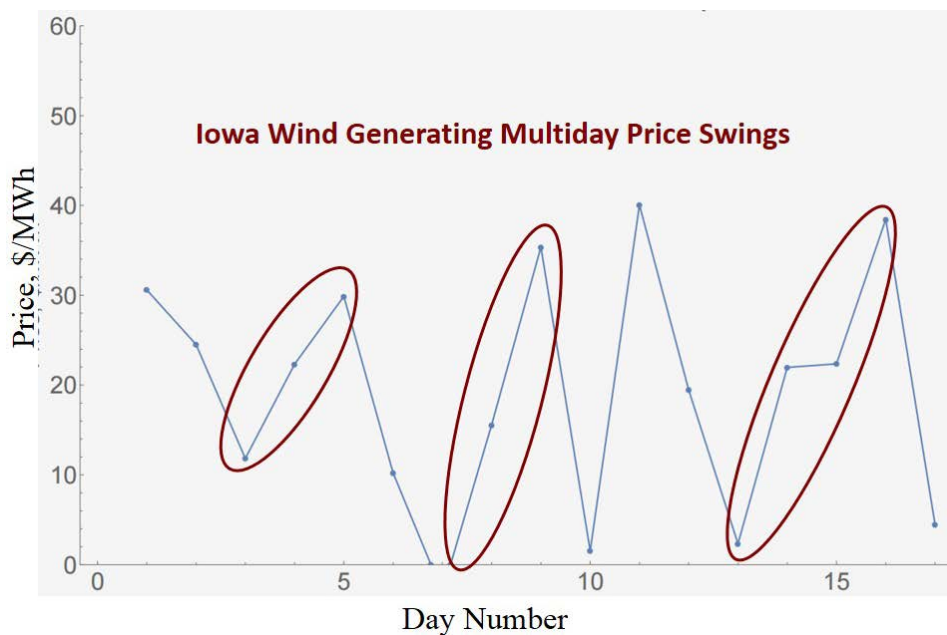

Fig. 2.2. Impact of Wind on Daily West-Iowa Electricity Prices in April 6-22, 2014

All high-capital-cost low-operating-cost technologies will collapse the price of electricity at certain times if deployed on a sufficiently large scale, and thus limit their deployment. The number of hours per year with collapsed prices increases with scale of deployment. The above examples are at times of year when this effect first appears. This price collapse (Haratyk, 2017) occurs as solar provides ~15% of total electricity demand, wind provides ~30% of total electricity demand or nuclear

provides ~70% of total electricity demand when fossil fuels provide the remainder of the electricity. Price collapse with solar occurs at a much smaller fraction of total electricity produced because there is no solar at night and the seasonal variation in solar output. The high nuclear fraction before price collapse reflects the base-load component of the electricity demand where minimum electricity demand occurs in the middle of the night. Price collapse economically limits the deployment of all low-carbon technologies with deployment of any low-carbon technology making the other low-carbon technologies less economic.

Price collapse is driven by non-dispatchable electricity generators. While wind and solar are the primary non-dispatchable generators, there are other such generators that are important in specific markets such as many hydroelectricity facilities. These include run-of-the-river dams and some fraction of the output of most other dams because of the requirement to maintain minimum river flow for fish, navigation, and other purposes.

This market effect has two impacts. First, the deployment of these technologies favors deployment of low-capital-cost high-operating-cost fossil plants to provide electricity at other times when prices are higher. Second, this change in the market creates the economic incentive to deploy energy storage systems to consume low-price energy (raise its price) and provide energy at times of higher demand.

The examples above indicate there is not one storage market. The storage cycles in a market with large quantities of solar generation are different than the storage cycles in a market dominated by wind. The variation of electricity demand is different across the country with large differences due to different climates and types of industrial load. One does not expect that there will be a “single” economically optimum storage solution. The optimal storage solution will vary with location.

2.2. Energy, Capacity and Auxiliary Service Markets

There are three electricity markets that can produce revenue for any storage system (Parsons, Appendix C)—each with different characteristics.

Energy markets. Energy markets pay per unit of energy delivered to the electricity grid. Figures 2.1 and 2.2 show the variation in prices in selected energy markets versus time that creates the fundamental economic case for all energy storage systems—store energy when prices are low to sell when prices are high.

The revenue potential of storage depends upon two characteristics of energy markets. The first is how many cycles of energy storage are needed per year. If the number of cycles is doubled, energy storage costs are decreased by a factor of two. The other factor is the difference between the low and high prices.

On the production side, both of these factors strongly depend upon the scale of wind and solar deployment. The larger the deployment of these technologies, the stronger becomes the economic

case for storage. On the demand side, there are daily, weekly, and seasonal variations in demand.

Coupled to energy markets is transmission congestion that locally decreases wholesale electricity prices at particular times. To address this challenge, the grid operator may request reduced production and use various out-of-market payments for services rendered. This is a particular concern in parts of the Midwest United States. Storage would address some of the transmission constraints.

The economic constraints for storage are severe—particularly if the competition is low-price natural gas. A recent analysis by Brick (Appendix C) shows the impact on the cost of electricity for storage for using batteries at their current capital costs of \$500/kWh and at an optimistic cost of \$100/kWh versus utilization rate (Fig. 2.3). Recent studies (Schmidt, 2017) of eleven electrical storage technologies based on experience rates concluded capital costs are on a trajectory toward \$340/kWh plus or minus \$60/kWh once one TWh of capacity is installed. A 100% utilization rate assumes one storage cycle per day. The analysis assumes 90% round-trip efficiency and a 10% capital recovery factor.

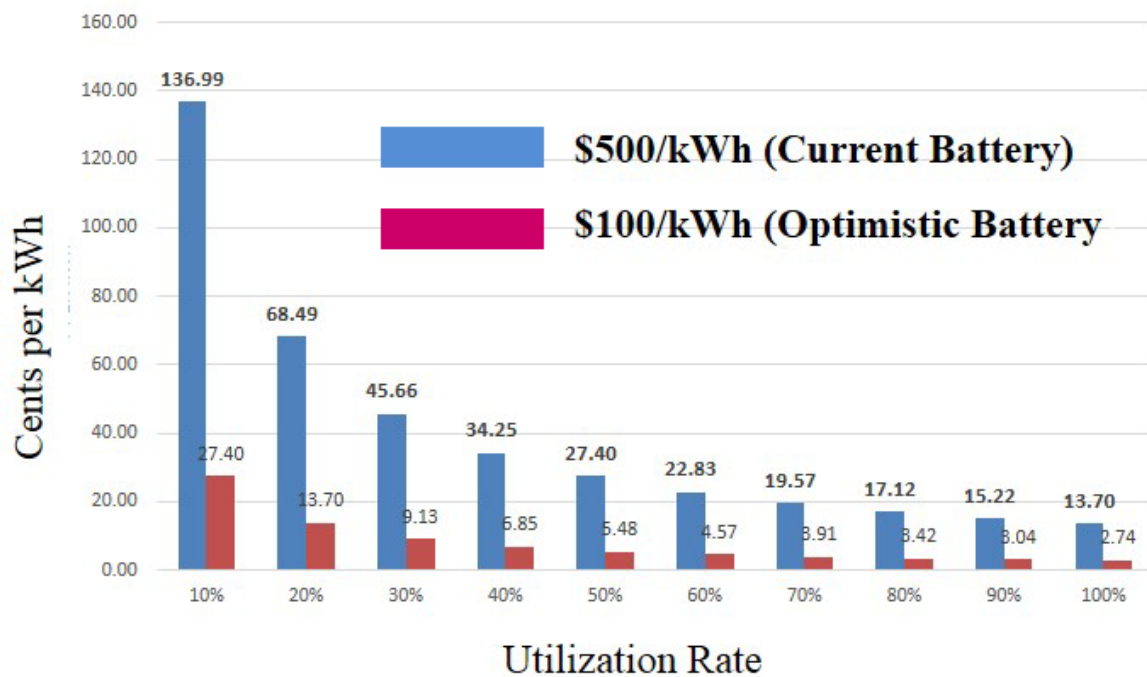

Fig. 2.3. Capital Cost of Storage versus Utilization Rate for Existing and Optimistic Battery Costs

Figure 2.4 shows similar numbers assuming the optimistic battery capital cost of \$100/kWh and the goal for some thermal energy storage systems of \$10/kWh. Cost is the storage challenge.

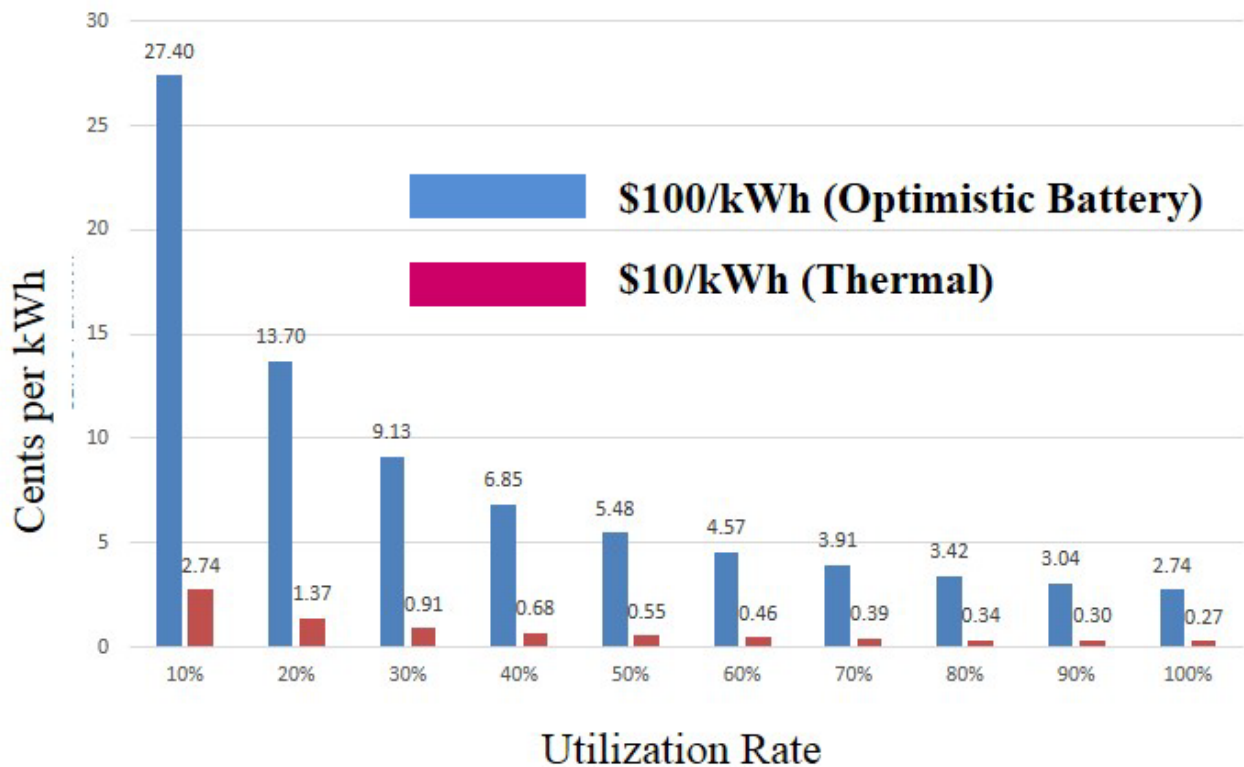

Fig. 2.4. Capital Cost of Storage versus Utilization Rate for Existing and Optimistic Battery Costs

As will be discussed later the above analysis provides a good perspective for stand-alone storage technologies such as pumped hydro and batteries but is not fully applicable to thermal storage coupled to LWRs because some of the storage technologies provide added capacity and services (below).

Capacity Markets. There are two strategies to assure sufficient generating capacity to meet demand; that is, to avoid blackouts. The first is to have no capacity market and allow energy prices to go to very high levels (\$1000s/MWh or more) at times of scarcity. Plants will be built whose revenue depends upon incomes during the sale of electricity for tens or hundreds of hours per year when prices are very high.

The second strategy is for the grid to have contracts for assured electricity supply (capacity market) even if there are multiday periods of low solar production, month-long periods of low wind (such as January 2017 in Europe) or extreme weather events (United States). Most electricity markets have capacity markets where the grid operator pays so many dollars per megawatt of assured capacity. In effect, the grid operator pays to lower the risks of blackouts because the high costs of such blackouts in terms of economics, public health risks (cold houses, summer heat exhaustion, etc.) and social disruption.

Capacity markets are a type of insurance. Without capacity markets (only energy markets), a small number of hours with very high prices provide the large majority of total revenues to certain types of generators. In a simple illustration produced by Joskow [2008], the 20 hours a year (< 1%)

with a theoretically permitted wholesale price of \$4,000/MWh provides 33% of the net revenues earned by a base-load plant, 50% by an intermediate plant, and 100% by a peaker. With a capacity market, the same revenue is provided as a capacity payment, and the wholesale price does not spike to \$4,000/MWh. Instead the same revenue is provided by a ~\$9/MWh fee for all hours yielding a capacity payment of ~ \$80/kW-year

Historically capacity markets were not needed or the payments were very low because the electricity was generated by nuclear and fossil units. These are dispatchable electricity sources. The addition of wind and solar have increased the use of capacity markets because these energy sources can't assure production of electricity given their intermittency.

Most storage technologies can't enter the capacity markets because their storage times are too short. However some thermal energy storage technologies have low-cost storage that may enable them to obtain payments in the capacity markets for assured capacity. Storage system cost can be divided into two major components: (1) the cost of the system that converts stored energy to electricity and (2) the cost of storing the energy. In a pumped hydro facility the first cost is associated with the pumps, turbines and generators while the second cost is associated with building the two water reservoirs. If a storage system is to compete in the capacity market it needs very low energy storage costs to enable storing large quantities of energy. In some heat storage systems (sensible heat, hot rock and geothermal) this cost is very low and thus may enable such storage technologies to participate in capacity markets.

Auxiliary Services Market. This refers to other electricity grid services such as frequency control, black start (start after power outage) and reserves for rapid response grid emergencies such as another electrical generator failing. Most of the thermal storage technologies associated with LWRs have some capabilities to provide these services as described below but this is not a large source of revenue in any electricity grid [Parsons, Appendix C].

3. HEAT STORAGE TECHNOLOGY OPTIONS

3.1. Reactor Constraints

Economic and technical considerations impose constraints on LWRs with heat storage.

Constant full reactor output. To minimize costs of energy production and minimize operational challenges, the high-capital-cost low-operating-cost reactor should be operated at full power all the time. The steam from the reactor can be divided between the main turbine and the storage system.

Minimum electricity to the grid. For the power plant to maintain its capability to rapidly send 100% of its rated capacity to the grid, a minimum steam to the turbine is required for the turbine to remain on-line to allow rapid return to full power by shutting off steam going to storage. Typically minimum power to the grid is near 30%. However, in many existing plants instabilities in the Balance of Plant (BOP) limit the minimum power to the grid to about 60% to 70% implying 30% to 40% of the steam can go to the storage system. With new plants or changes in existing plants, the minimum power level can be much lower. If the main turbine is shut down, it can be hours before it can be put back on line.

There are several implications of operating the power conversion system at part load and the reactor at full power. First, the power plant can respond to rapid changes in electricity demand to maximize revenue such as changes in price shown in Fig. 2.1. Second, the plant can provide some auxiliary services. There are costs. The efficiency of the main steam plant goes down as the load goes down (Fig. 3.1).

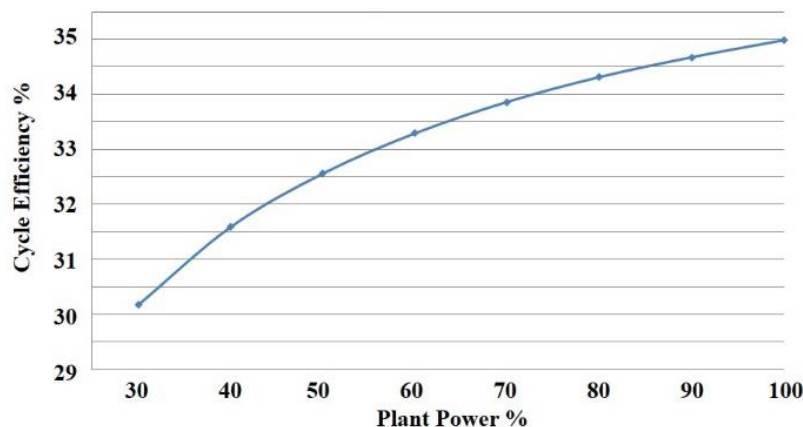

Fig. 3.1. Typical 1200 MWe Pressurized Water Reactor Plant Cycle Efficiency vs. Power Level.

Courtesy of Westinghouse Corporation

Maximum electricity to the grid. This is equal to the base-load capacity of the power plant plus the power output from the energy storage system. For some technologies this output can be 2 to 3 times

the base-load electricity output. It is a design variable.

The other consideration is how to couple the LWR to the heat storage system. There are two broad sets of options with many variants and some combination systems. In Europe and Asia a number of LWRs produce steam for electricity and off-site customers so there is considerable real-world experience in nuclear plants producing electricity and exporting heat [IAEA, 2017].

Stand-alone Storage Systems. With this option steam is diverted before the high-temperature turbine and sent to the storage system that has its own power generation system. Condensate water is returned to the reactor. The steam is diverted before the high-temperature turbine because steam from the reactor is at a constant pressure and temperature. Steam diverted from other locations in the turbine hall has variable temperature and pressure depending upon plant operations.

There is relevant experience in the United States about what is required to do this. About a decade ago the Fort Calhoun Nuclear Power Plant [Gaspar, Appendix C] did detailed engineering and cost studies, including discussions with the Nuclear Regulatory Commission, on diverting some of its steam to a nearby Cargill industrial plant with return of the condensate water to the reactor. The conclusion is that this was practical, economic, and had no significant impact on safety. The project did not go forward for other reasons.

Integrated Storage Systems. With this option steam is diverted to storage at times of low demand and heat is sent back to the turbine hall at times of high demand to produce added electricity. The main turbine is used to produce the added electricity.

This option has two advantages. First, the incremental capital cost to the power cycle for added electricity output is significantly lower than with a stand-alone power system coupled to heat storage. Second, the main turbine is always operating which enables fast response to changing electricity demand. There are disadvantages. There are practical limits on the peak power relative to base-load power—perhaps 20% higher. The peak turbine efficiency varies with load so that efficiency will be lower at either base-load or the peak power level. Last, this option is easy to design into a new plant but the ability to economically modify an existing plant depends upon the specific plant.

The characteristics of LWR steam cycles provide multiple options on how to integrate heat storage into the power cycle. Some of those options are shown in Fig. 3.2. Up to a third of the steam from the reactor is diverted from the turbines in different locations to feed-water heaters to improve plant efficiency. The different feed-water heaters operate at different temperatures. Stored heat can be sent back as steam to the main turbine or to the feed-water heaters to allow more primary steam to the turbines.

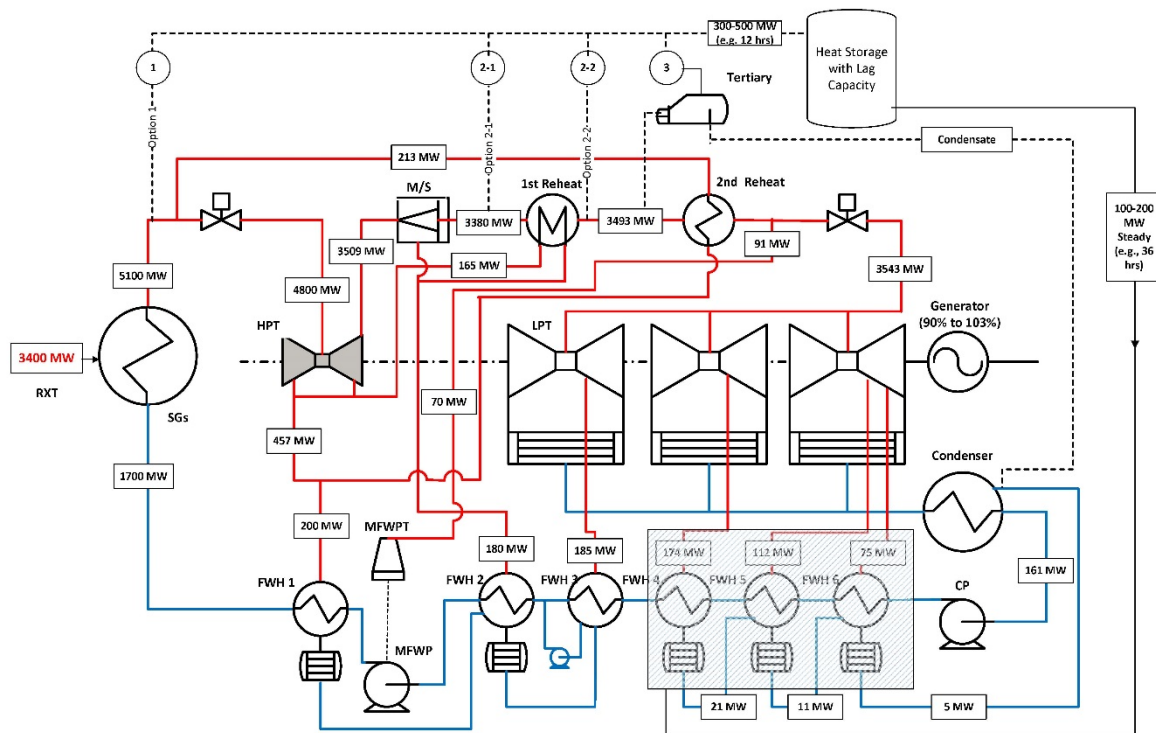

Fig. 3.2. PWR Steam Plant with Selected Options for Steam Removal and Return to Turbine Plant

The options [Varrin, Appendix C] shown in Fig. 3.2 is one set that would be potentially attractive for back-fitting to an existing PWR. The plant can divert large quantities of steam to storage without major modifications to the turbine hall when electricity prices are very low—something that happens for limited periods of time (Fig. 2.1 and Fig. 2.2). However, sending large quantities of heat back to the turbine hall could require major upgrades of the turbine-generator set and possibly the transmission grid. The strategy shown herein is boosting the plant power output by a third or fourth the rate of maximum heat withdrawal to avoid major changes in the turbine-generator set. When viewing the nuclear plant as a black box, the addition of storage integration into an existing PWR with this approach would appear to have resulted in (1) a small increased its “base-load” capacity (<5%), (2) a large increase in the capability to rapidly ramp down power levels (20 to 25%) and (3) a significant lowering of the minimum plant output to the grid. The minimum electricity production may then be determined by how much the reactor power can be reduced plus how much steam can be sent to storage without tripping the turbine.

Heat storage can be coupled to any type of reactor. However, heat storage options have only been explored in any detail for coupling to light-water reactors (LWRs)—the current technology. The workshop focused on LWRs because they are the dominant reactor type worldwide. The same storage technologies apply to all other water-cooled reactors with steam cycles and with some constraints to other reactors with steam cycles.

3.2. Thermal Storage Options

Six classes of storage technologies that couple to LWRs were examined where steam is the input to the storage system. For some options, there is the choice to get steam from the storage system that could be fed back to the main reactor turbine if that turbine was oversized. These options can also store heat for later use by industry. Some of these technologies have been deployed in solar thermal power systems [Kuravi 2013] while other technologies are primarily in the research stage. Most new utility-scale solar thermal power systems [Harvey, 2017] include heat storage to avoid selling electricity at times of low prices. The storage times for different technologies vary from hours to seasons

3.2.1. Steam Accumulators (Direct hot water/steam storage)

A steam accumulator [Mann, Appendix C] is a pressure vessel nearly full of water that is heated to its saturation temperature by steam injection (Fig. 3.3). Heat is stored as high-temperature, high-pressure water. In addition to its fairly high thermal conductivity, liquid water has a high volumetric heat storage capacity of up to 1.2 kWh/m³ [Medrano et al., 2010]. When steam is needed, valves open and some of the water is flashed to steam and sent to a turbine [LaPotin, 2016], producing electricity, while the remainder of the water decreases in temperature.

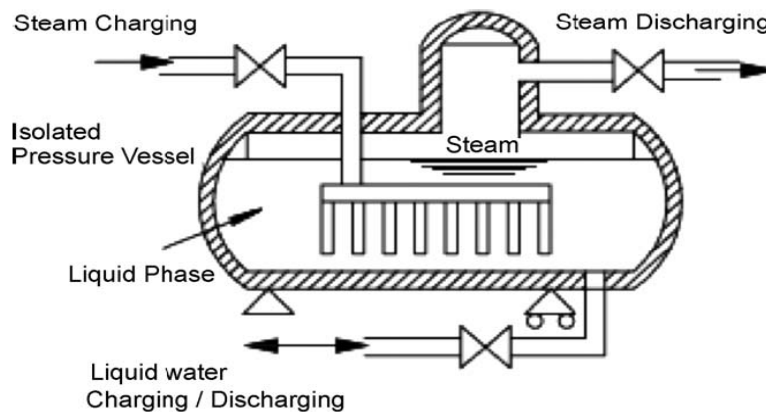

Fig. 3.3. Steam Accumulator Schematic

Steam accumulators have been used as pressure buffers in steam plants for over a century. The first large steam accumulator built to produce peak electricity was the Charlottenburg Power Station built in Berlin in 1929 with a peak electricity output of 50 MWe and a storage capacity of 67 MWh. The steam was provided by a coal-fired boiler and the accumulator had a separate turbine. This accumulator had 16 tanks each 4.3 meters in diameter and 20 meters high (Fig. 3.4). There are

multiple commercial suppliers of steam accumulators—but not at the size that would be associated with a LWR.

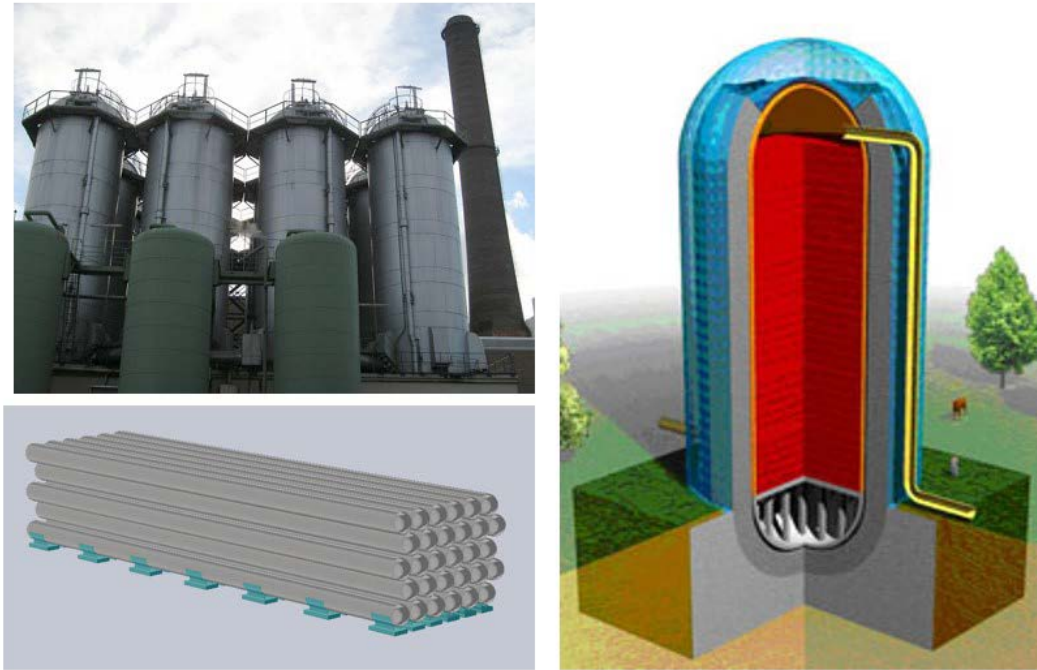

Fig. 3.4 Alternative Accumulator Options: Steel Vessel Charlottenburg Power Station Accumulators Built in Berlin in 1929 (Upper Left), Proposed Pipe Rack Accumulator (Lower Left) and Prestress Concrete Vessel (PCV) (Right, Proposed Adele PCV for Adiabatic Compressed Air Storage System [Zunft, 2014]; Schematic (right) courtesy of Zublin).

Steam accumulators have been installed in many concentrated solar power plants. The characteristics of some of these systems is shown in Table 3.1. Steam accumulators are well-suited for CSP designs where steam is generated in pipes located at the foci of parabolic or Fresnel reflectors [Steinmann, 2006; Hirsch, 2014]. At the PS-10 and PS-20 plants near Seville, Spain, steam accumulators are coupled to the steam loops for heat storage, allowing them to produce electricity at times of high prices and low sunlight [Kuravi, 2013]. The operating temperatures and pressures of the solar power systems are close to those in LWRs (up to 400 °C, 100 bar).

Table 3.1. Solar Power Accumulators [Han, 2009; NREL, 2017]

Name	Location	Online	Type	HTF	Outlet [°C/MPa]	Power [MW _e]	Energy		
							Cap. [hours]	Sensible TES	Latent TES
PS10	Sevilla, Spain	2007	CSP Tower	Steam (DSG)	250/4.5	11	0.5	N/A	Steam acc.
PS20	Sevilla, Spain	2009	CSP Tower	Steam (DSG)	250/4.5	20	0.5	N/A	Steam acc.
DAHAN	Beijing, China	2012	CSP Tower	Steam (DSG)	400/4.5*	1	1	Mineral oil	Steam acc.
Khi Solar One	Upington, South Africa	2016	CSP Tower	Steam (DSG)	530/4.5*	50	2	N/A	Steam acc.
eLLO	Llo, France	(2018)	CSP Linear Fresnel	Steam (DSG)	285/7.0	9	4	N/A	Steam acc.

Most of the energy in a steam accumulator is stored as pressurized hot water because the energy storage density is higher. For a 100 MWh of electricity storage with steam delivered from 70 to 20 bars, one needs to store the equivalent of about 1000 tons of steam (286°C, 70 bar) that would occupy 27,000 m³. The same energy is stored in 7900 m³ of pressurized hot water or a reduction in storage volume by 3.4.

There are two classes of accumulators. The variable pressure (Ruths) accumulator is a single tank accumulator with sliding pressure during operation. It is the primary type of steam accumulator in current use. There is a more complex expansion accumulator that may be of interest for very large accumulators but is not generally used. The expansion accumulator involves two tanks: an accumulator tank that operates at constant pressure and an evaporator tank that delivers constant pressure steam. During discharge hot pressurized water is transferred from the accumulator tank to the expansion tank while cold water is added at the bottom of the accumulator tank to maintain a constant pressure with a thermocline separating the hot and cold water.

Steam accumulator performance can be improved by strategically adding other heat storage materials to the system. Phase-change materials (PCM) like sodium nitrate salts can be added within or around the stored water–vapor mixture to increase the total heat capacity of the system. During charging, heat is stored by melting the PCM (enthalpy of fusion), and it is released back into the water–vapor mixture during discharge, re-solidifying the PCM. Additional heat could be stored in sensible heat storage materials (e.g., high-temperature concrete) for preheating condensate water or for reheating or superheating steam from the accumulator. Reheating may be necessary in some designs to improve the steam quality that feeds into the turbine [Birnbaum et al., 2010]. A

demonstration project for these concepts was built at the Litoral de Almería coal-fired power plant in Spain [Laing, 2011] to support steam accumulators for solar thermal power systems.

There have been limited studies of coupling steam accumulators to nuclear power plants for load following. Early studies [Gilli, 1970; Gilli, 1973] of such accumulators coupled to LWRs were done in the 1970s when the Arab oil embargo raised oil prices—the fuel used for peak power production. The University of Texas has recently conducted a series of studies on the use of accumulators. This included steam accumulators [Lane, 2016; Bisett, 2017] that can provide heat to the feed-water heaters in the nuclear plant and boost the power output of the main nuclear steam turbine. Mann [2017] examined the economics in the context of the Texas electrical grid and under what conditions the economics were favorable.

The defining feature of a steam accumulator for nuclear applications is the required heat storage capacity—significantly larger than for other applications. This will not change the technology for the power cycle but may change the technology used to store the hot pressurized water. Historically steel vessels have been used. For very large accumulators there are two other options that may have lower costs per unit volume (Fig. 3.4).

- *Steel pipe.* Recent studies have proposed kilometers of large steel pipe in racks inside an insulated building to avoid insulation of individual racks. Steel pipe used in pipelines is manufactured in very large quantities that will minimize manufacturing costs.
- *Prestressed concrete reactor vessel.* This would be a single large vessel. There has been recent work in Germany in development of such vessels as a component of an adiabatic compressed air storage system (Project Adele) at higher pressures and temperatures than in steam accumulators. The basis for that work is the lower projected costs for high volume storage at pressure. This work is directly applicable to steam accumulators.

3.2.2. Heat Storage (oil, salt, etc.) In Secondary Low-Pressure Media

Sensible heat storage [Fitzhugh, 2016; Edwards, 2016; Frick, June 2017; Frick, October 2017] involves heating a second fluid with steam or hot water, storing that second hot fluid at or near atmospheric pressure, and using that hot fluid later to produce steam that is used to produce electricity or for some other purpose. This heat storage technology is used with many solar thermal systems. A range of fluids have been used in such solar systems, including oils and molten nitrate salts. There are two physical configurations: two-tank and thermocline systems. In a two-tank system, one tank holds

cold fluid and one holds hot fluid, with the ratio of fill levels in the tanks indicating the state of charge. In a thermocline system, hot fluid is injected at the top of the tank, and cold fluid is injected at the bottom. In both cases, one heat exchanger is used to heat the fluid during charging and one is used to cool the fluid to produce steam during discharging. The use of two heat exchangers allows the rate of steam input into storage to be sized separately from the rate of heat output based on market economics. In markets where electricity prices go near zero, the input heat rates may be much higher than the output rates. In solar thermal systems two-tank sensible heat storage has been demonstrated at the 100 MWh scale, and the thermocline type has been demonstrated at the 1 MWh scale.

Two separate studies have examined coupling sensible heat storage to LWRs. The North Carolina State [Doster, Appendix C] and Westinghouse [Stansbury, Appendix C] designs enable peak power capabilities 20 to 25% higher than base-load power. Both studies concluded heat transfer oils are likely to be the preferred heat transfer fluid when coupling sensible heat storage to an LWR.

The North Carolina State University studies [Frick, June 2017; Frick, October 2017] examined the use of oil heat transfer fluids for heat storage coupled to small modular pressurized water reactors for variable electricity production. The system can be scaled to any size. The analysis simulated reactor operations where the reactor operated at constant output with variable electricity to the grid. The flow sheet is shown in Fig. 3.5. Organic heat transfer fluids have been used in the chemical industry since the 1920s and since the 1980s in solar thermal power systems. In this case the chosen fluid is Therminol[®]-66 that has an operational range of -2.7 to 343.3°C, a boiling point of 358°C and a heat capacity of 1.039 kWh/(m³-°C). The Nevada Solar One heat storage system uses Dowtherm A, a similar heat transfer fluid, for heat storage [Kuravi, 2013].

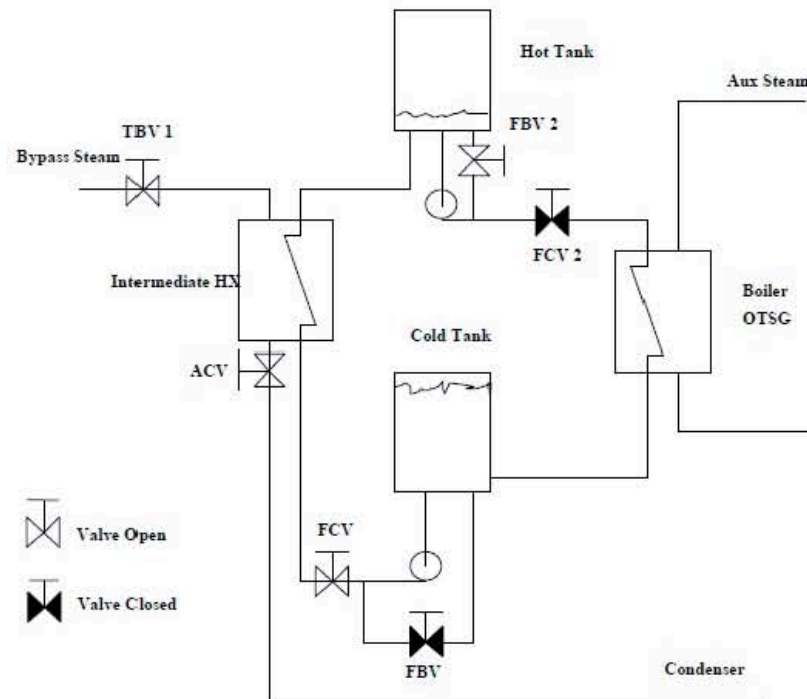

Fig. 3.5. Nuclear Thermal Energy Storage System (Charging Mode)

Westinghouse [Stansbury, Appendix C; Westinghouse 2016] has begun development of a sensible heat storage system for LWRs (Fig. 3.6) where each storage module stores sufficient heat to generate one MWh of electricity. Steam heats the low-pressure oil that then transfers its heat to a heat storage module. The storage tanks have vertical concrete plates as the primary heat storage media rather than oil because concrete is much less expensive than oil as a heat storage media and the concrete plates can be manufactured locally. The hot oil flows through narrow channels between slabs of concrete. To recover the heat, the direction of oil flow is reversed. The hot oil can be used to generate steam that is sent to (1) the main reactor turbine, (2) a partial replacement for steam to feed-water heaters, or (3) a separate power system.

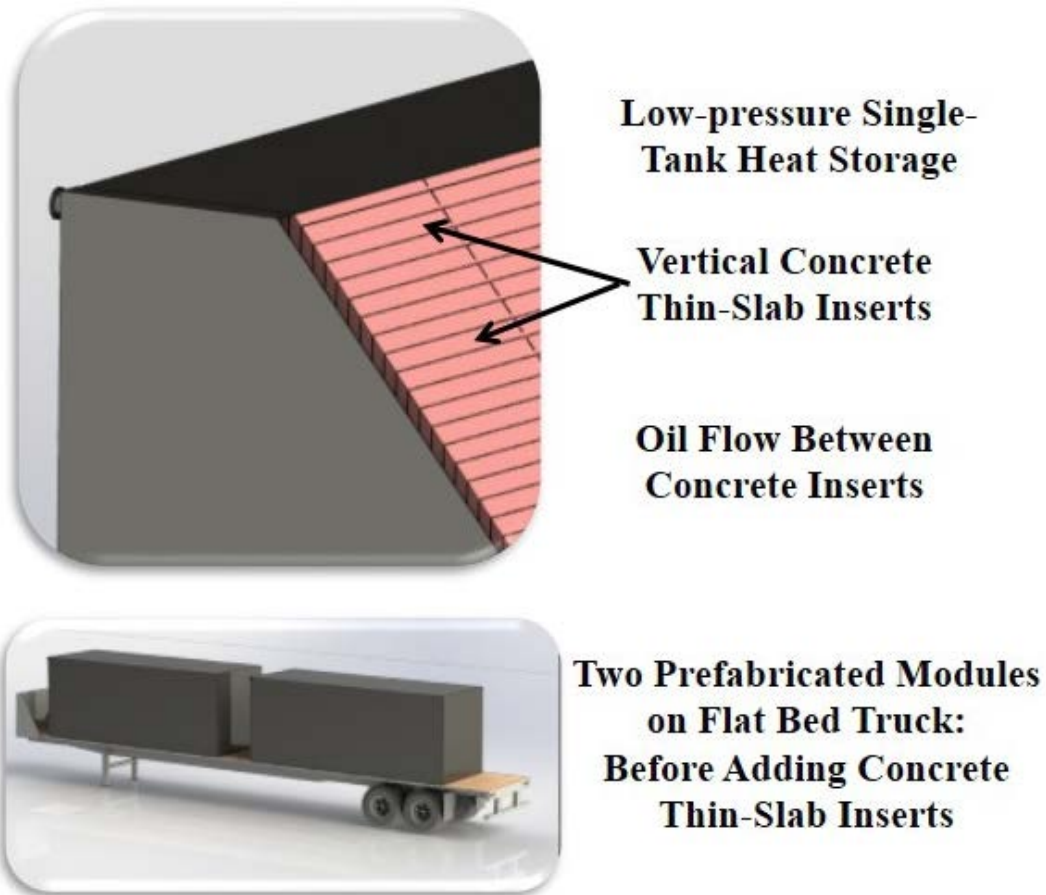

Fig. 3.6. Westinghouse Thermal Heat Storage Module for 1 MWh of Electricity Storage

For existing nuclear plants the heat storage capacity would be up to 1-GWh with a heat input rate equivalent to 200 MWe and an output rate of 100 MWe. The round trip efficiency would be about 60% with options for significantly improved efficiency. Options are more limited for existing plants than for new plants. In a new plant the peak power output would be 20 to 25% greater than the base-load capacity using the main turbine for the peak power output to minimize capital costs and enable fast response. There would be a slight loss in base-load plant efficiency (~1%) for this peaking capability.

3.2.3. Cryogenic Liquid Air Storage

A cryogenic air energy storage system [Ding, Appendix C; Chen, 2007; Li, 2014; Ding, 2016; Highview, 2017] stores energy by liquefying air (Fig. 3.7). A less tightly coupled cryogenic system would use electric motors to drive the chilling process; the option exists to more tightly integrate the chilling process with the nuclear plant and provide steam for steam turbines in the air liquefaction plan. This is a common chemical industry practice because of the lower cost of steam turbines

compared to large motors. During the liquefaction process, the compression heat can be stored for reuse in the power recovery (discharge) process; whereas waste cold during the discharge process can be stored for later use in the liquefaction process to reduce power consumption. The liquefied air can be stored in facilities similar to those used to store liquefied natural gas (LNG). The energy storage capacity of the liquid air reservoir and round-trip efficiency can be enhanced through the integration of a sensible/latent heat and cold storage system.

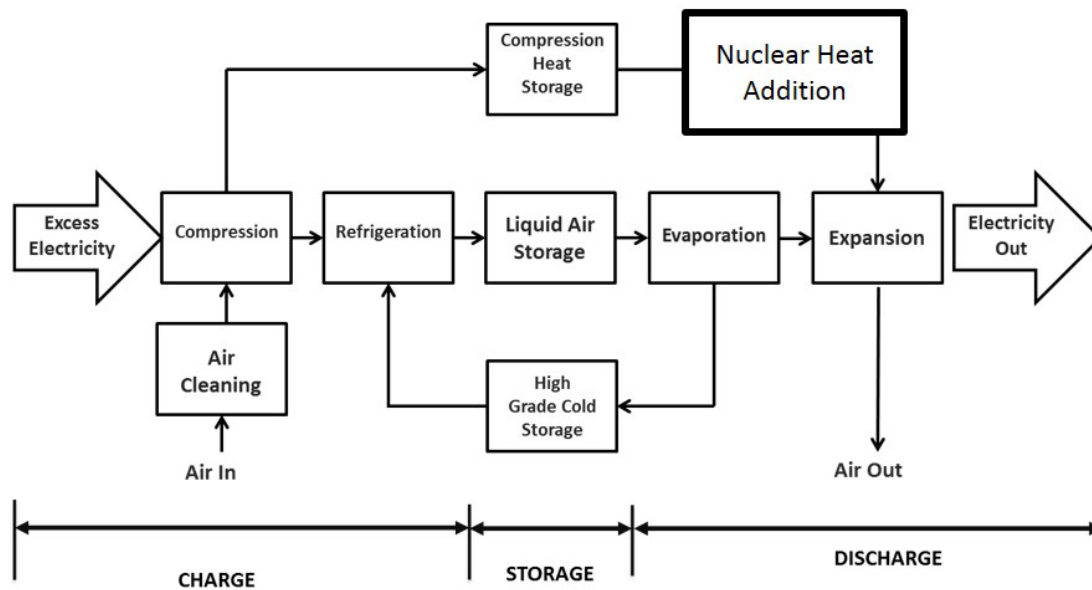

Fig. 3.7. A schematic diagram of the cryogenic energy storage technology [Ding, 2016]

To produce electricity, the liquid air is compressed to high pressures, converted to a high-pressure gas using ambient heat and available waste heat including that from the nuclear power plant tertiary side (warm cooling water), further heated in a heat exchanger using steam from the nuclear power plant secondary side and sent through a gas turbine before being exhausted to the atmosphere. This potentially provides a low-cost peak power cycle. During this power recovery process, cold energy can be recovered through heat exchange for use in the liquefaction process as mentioned above.

If only warm cooling water from the nuclear plant or other low-temperature heat source is used, the estimated round-trip efficiency of a stand-alone system is around 60% [Ding, 2016]. With an integrated cryogenic-nuclear power plant system (steam to heat compressed air) the round-trip efficiency can be between 70 and 75% [Ding, 2013; Li, 2014; Ding, Appendix C] with a peak power up to 2.7 times the base-load power plant capacity. The reason for the high efficiency and power output is that the LWR steam is adding heat to boost the efficiency of a liquid-air cycle and is a thermodynamic topping cycle. Normally one does not consider LWR steam to be high-temperature

heat but in a power cycle where the bottom temperature is the temperature of liquid air (-194°C ; 79°K), 270°C steam is hot.

A small pilot plant (350 kW/2.5 MWh) is in operation and a commercial non-nuclear demonstration plant (5 MW/15MWh), shown in Figure 3.8, is due to be operational in July 2017, both in the United Kingdom.



Fig. 3.8. Highview 5MW/15MWh Commercial Demonstration plant in Manchester Integrated with Viridor Biogas Power Plant

This storage technology is applicable to any reactor type. What changes is the entry temperature of the air into the gas turbine—a simple change because modern gas turbines operate at temperatures far above any reactor coolant temperature.

3.2.4. Pressurized Counter-Current Condensing-Steam Solid Heat Storage

A packed-bed thermal energy storage system [Bindra, Appendix C; Bindra, 2013; Edwards, 2016a, Edwards, 2016b] consists of a pressure vessel filled with solid pebbles with a steam valve at the top and water outlet at the bottom. Heat is stored as sensible heat in the pebbles. At the end of a discharge cycle, the pebble bed is filled with cold water. To charge the system (Fig. 3.9), steam is injected at the top of the vessel as water is drained from the bottom of the vessel. The steam condenses as the cold pebbles are heated. Because of the extremely good heat transfer of condensing steam, the steam condensation occurs in a small band resulting in hot pebbles above the condensation zone and cold pebbles below the condensation zone. At the end of the charging cycle all pebbles are hot and are in a steam environment.

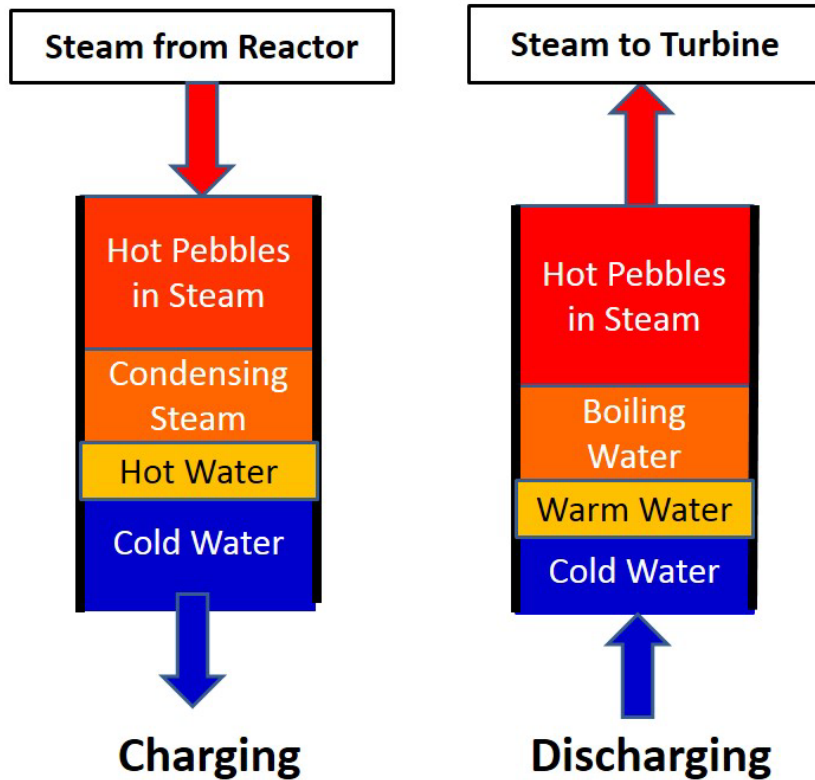

Fig. 3.9. Operation of Pressurized Counter-Current Heat Storage

During the discharge cycle water is added at the bottom of the vessel. The hot water is converted into steam by the hot pebbles and sent to a turbine to produce electricity. Because boiling is highly efficient, heat transfer occurs in a small zone from bottom to top with the steam leaving the vessel as hot steam as it flows through the remainder of the hot packed bed.

In theory this should be the most efficient heat storage system in terms of round-trip efficiency. The heat storage system directly uses steam with no temperature losses in a heat exchanger in either direction—steam in and steam out. Packed beds are more thermodynamically efficient than other storage systems because they operate in a counter-current mode—the hottest steam sees the hottest pebbles. A sharp hot-to-cold front with small dimensions is only possible with a saturated-steam input where the very high heat transfer of condensation and boiling occurs over a very small zone in the bed. This is not true for superheated steam and other systems where the length of the heat transfer zone becomes excessively long relative to practical dimensions of real systems. There has been limited experimental work. Figure 3.10 shows some recent experiments with a packed column and the sharp line of condensation.

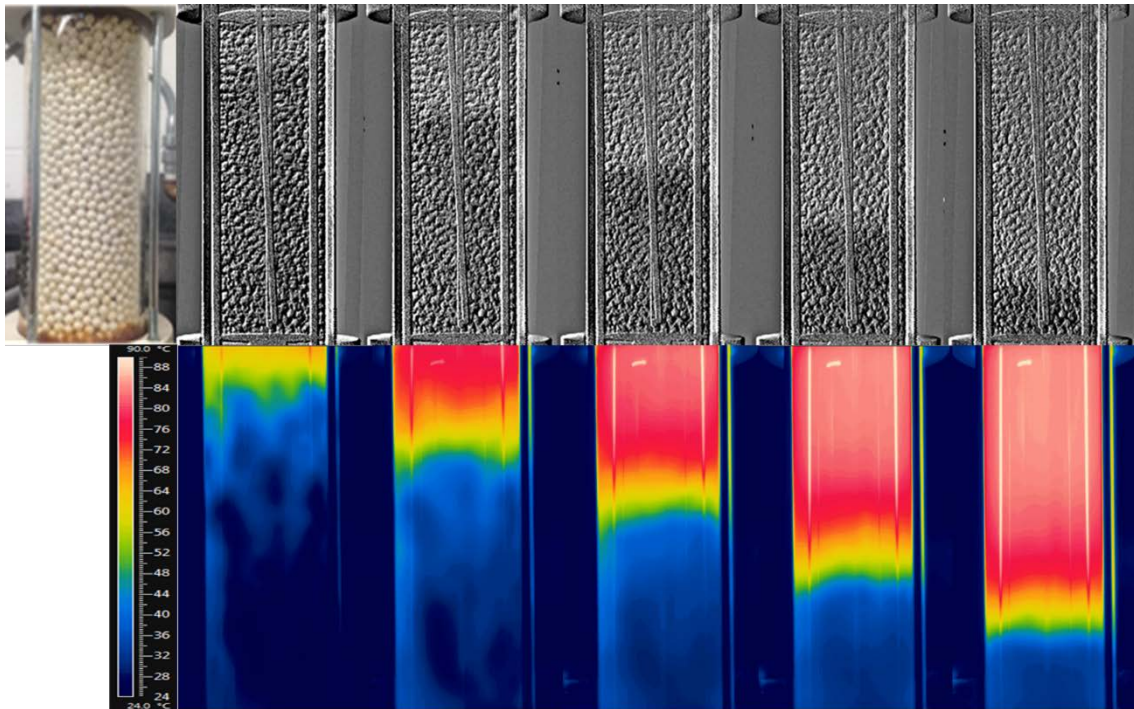

Fig. 3.10. Atmospheric Steam as Heat Transfer Fluid and an Alumina Packed Bed as Storage Media, X-ray and IR Images Every 10 Seconds [Bindra 2017]

The design options for packed-bed systems, including the range of suitable pebble materials and sizes, and the impacts of pebble choice on dynamic performance, are only partly explored. The storage economics is likely limited to hourly and daily cycles because of the cost of the pressure vessel. This storage technology is applicable to water cooled reactors with steam cycles but would not be applicable to higher-temperature reactors with very high-temperature steam cycles. The higher storage system's performance is dependent upon steam condensation and boiling in a small zone.

3.2.5. Atmospheric-Pressure Crushed-Rock Heat Storage

A hot rock energy storage system [McLauchlan, Appendix C; Forsberg, 2017a] is similar in concept to a packed bed energy storage system except that it operates at atmospheric pressure. A volume of crushed rock with air ducts at the top and bottom is created (Fig. 3.11). To charge the system, air is heated using a steam-to-air heat exchanger delivering heat from the reactor, then the air is circulated through the crushed rock heating the rock. To discharge the system, the airflow is reversed, and cold air is circulated through the crushed rock. The discharged hot air can be used to (1) produce steam for electricity or industry or (2) hot air for collocated industrial furnaces to reduce natural gas consumption.

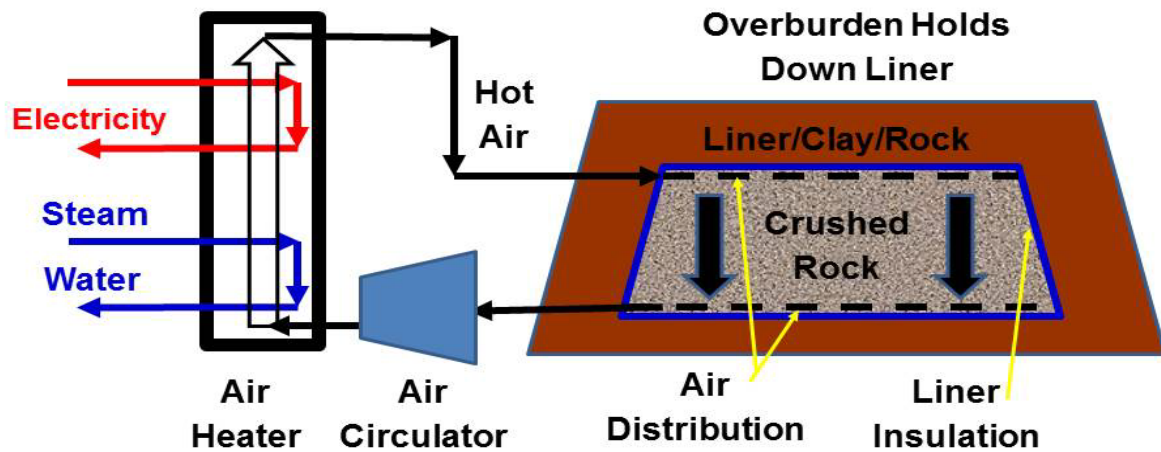

Fig. 3.11. Hot Rock Storage with Steam and Electric Input

Heat storage systems are only charged at times of very low electricity prices. There is the option with this system to first heat the air with a steam-air heat exchanger and then further heat the air with electric resistance heating. LWR steam peak temperatures are near 300°C—well below the temperature limits of the crushed rock. Higher temperatures improve system efficiency and reduce costs. This can substantially boost rock temperatures and the efficiency of converting hot air back to electricity, and reduce capital costs. Near atmospheric operating conditions increase safety and reduce storage costs.

There is ongoing work [Forsberg 2017b] on heating firebrick or rock to high temperatures at times of low electricity prices using electric resistance heating. Air would be blown through the hot rock to provide hot air to industrial furnaces and steam plants.

A variant of large hot-rock systems is under development by the shale oil industry (Red Leaf Inc.) to produce oil. In that system the rock is crushed oil shale and heated hot gases are circulated through the rock to decompose solid kerogen into liquid and gaseous hydrocarbon fuels. For that system the rock pile will be about 30 meters high. Much of the technology required for hot rock heat storage is being developed by such projects.

Only limited studies have been done of this option. The economics may allow hourly, daily, and weekly storage. The longer storage times may be possible due to the very low incremental heat storage cost for crushed rock—far lower than any of the previous options that have been discussed. As such this technology can address the weekday weekend storage challenge where energy demand goes down on weekends but the production of wind, solar and nuclear does not if these facilities are operated at their full capacity. It is a storage technology that could potentially receive capacity

payments for assured generation of electricity. With proper selection of rock for the expected peak temperatures, this storage system should be able to couple to most other reactors. The possible exception may be very high temperature reactors where finding suitable rock for such high temperatures may be difficult.

3.2.6. Nuclear Geothermal Heat Storage

Heat Storage

Geologic heat storage systems [Forsberg, Appendix C; Lee, 2010; Lee, 2011; Forsberg, 2012; Forsberg, 2013] combine the features of an enhanced geothermal energy facility with thermal energy storage. Thermal energy is stored (Fig. 3.12) underground by injecting hot water heated by the reactor from the surface into the rock reservoir; heat is primarily stored in the rock, and heat is recovered by water flowing through the rock back to the surface for electricity production in a conventional geothermal plant. Under certain circumstances, there may be the option to use carbon dioxide [Kulhanek, 2012] as the heat transfer fluid. This is the only heat storage option that is a candidate for hourly through seasonal energy storage because of the extremely low cost of the storage media—hot rock.

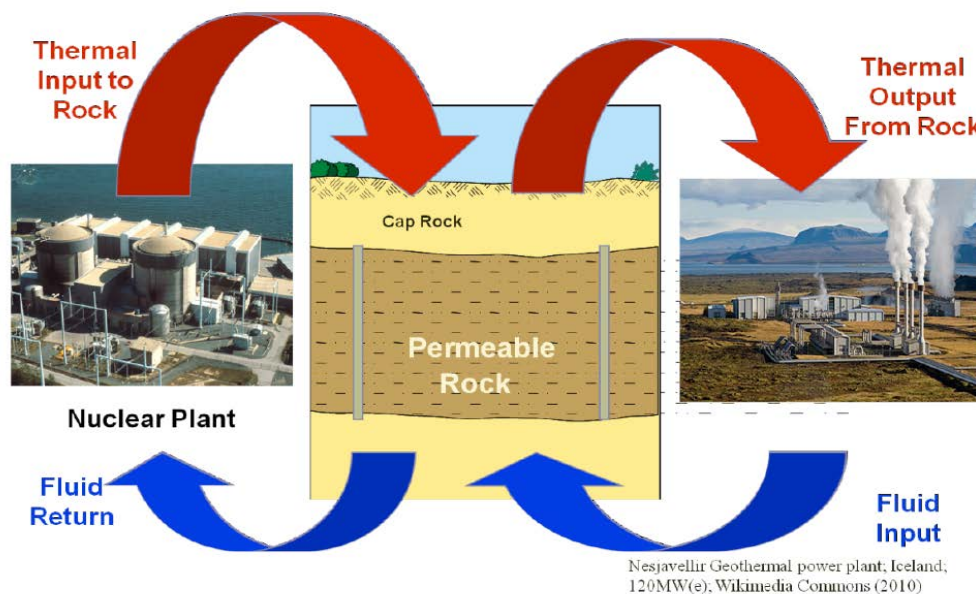

Fig. 3.12. Nuclear Geothermal Heat Storage

It is not possible to insulate rock 500 to 1000 meters underground. There is always the slow loss of heat by conduction into surrounding rock. However, heat losses are proportional to the surface area of the storage zone while heat storage capacity is proportional to the volume. Heat losses vary by the

square of the storage reservoir size while heat storage varies by the cube of the storage reservoir size; thus, heat losses decrease as the system size increases (Fig. 3.13). The minimum heat storage is a tenth of a gigawatt year—30 to 40 GWd of heat if heat losses are to be limited to a few percent of the heat being stored. As a consequence this system would be designed for hourly to at least weekly (weekday/weekend) storage. The minimum required scale matches nuclear plants or very large solar thermal systems.

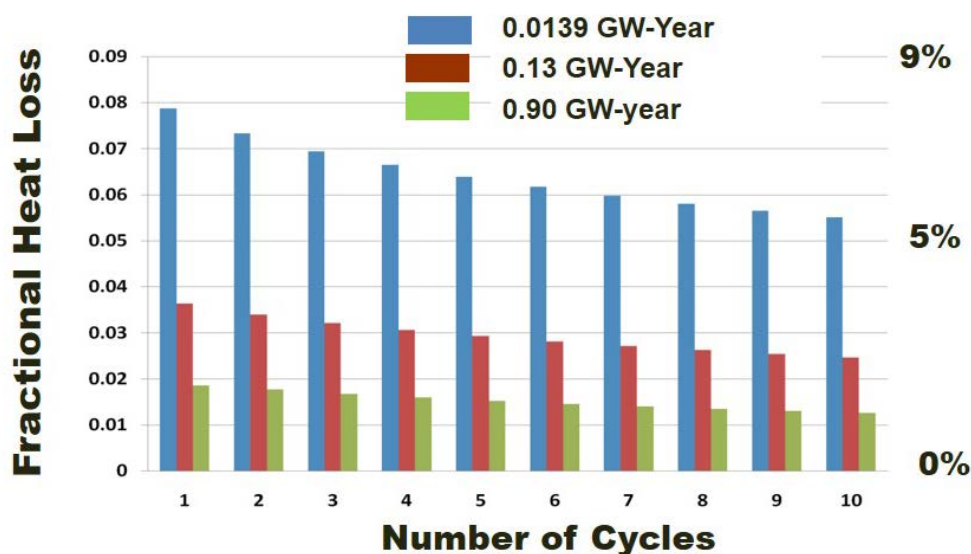

Fig. 3.13. Fractional Energy Losses vs. Cycle for Three Reservoir Sizes

Geothermal heat storage would couple to LWRs but not reactors with higher-temperature steam cycles. As water temperatures increase in rock, different elements in the rock dissolve into the water or precipitate from the water. The practical implications are that LWRs are near the peak allowable temperatures for water-based geothermal systems—higher temperatures create conditions where rock dissolution and precipitation may block pores and channels required for efficient hot water flow through the rock.

Geothermal power plants have historically had relatively low efficiencies [Moon, 2012]. A nuclear geothermal power plant has two differences relative to traditional geothermal power plants that should improve efficiency and reduce costs. First, the power output will be hundreds of megawatts versus tens of megawatts with gains in efficiency associated with larger equipment and more optimized equipment. This includes three-stage and possible four-stage flash power plants that are more efficient than two-stage flash systems but require more equipment. Second, the reservoir will have much cleaner hot water than a typical geothermal power plant. In most geothermal plants the hot

water or steam contains large quantities of carbon dioxide and other gases that lower steam cycle efficiency—including the need to remove large quantities of non-condensable gases from the condenser. In a nuclear geothermal system these gases and other impurities are “washed out” of the rock in the first few cycles of operation because the same rock is used again and again.

Heat can be added in two ways. The first option is to pump cold water from the underground geology, send it through a heat exchanger, and then inject it into the hot storage zone. There is a second option now being explored where steam is sent through a jet pump to heat the water and replace the conventional pumps. This option eliminates the temperature drops and costs associated with the heat exchanger resulting in higher round-trip efficiencies. It avoids the issues associated with fouling the heat exchanger with geothermal water. This would provide a low-cost method to send large quantities of heat into the storage reservoir. However, it comes with the added cost of needing large quantities of clean makeup water for the reactor steam generator. Nuclear geothermal heat storage is dependent upon appropriate geology. Unlike other storage systems it can't be built at all locations.

Earth Battery

Recent work on advanced underground energy storage systems [Buscheck, Appendix C; Buscheck, 2014; 2015; 2016; 2017] have combined underground heat storage, compressed gas storage (CO₂, N₂, or air), and potentially carbon dioxide sequestration (Fig. 3.14). These are enabled by advances in the ability to characterize underground rock formations and advanced drilling techniques [King, 2012]. Controlling hydrostatic pressures can create high pressure “walls” to minimize the migration of hot water and compressed gas from the system. This enables storing compressed gases—a second form of geological energy storage. This implies that the energy input at times of low electricity prices may be heat from reactors to create hot-water storage volume (and to heat rock) and electricity from the grid to create a compressed gas storage volume. The compressed gas can be used directly as an energy storage system or to pressurize the system so there is no need to pump hot water for heat recovery when the geothermal plant is operating. The waste heat of gas compression can also be stored together with heat diverted from the LWR. In principal, this approach could take all of the diverted thermal energy and remaining generated electricity from an LWR nuclear power plant during periods of over-generation.

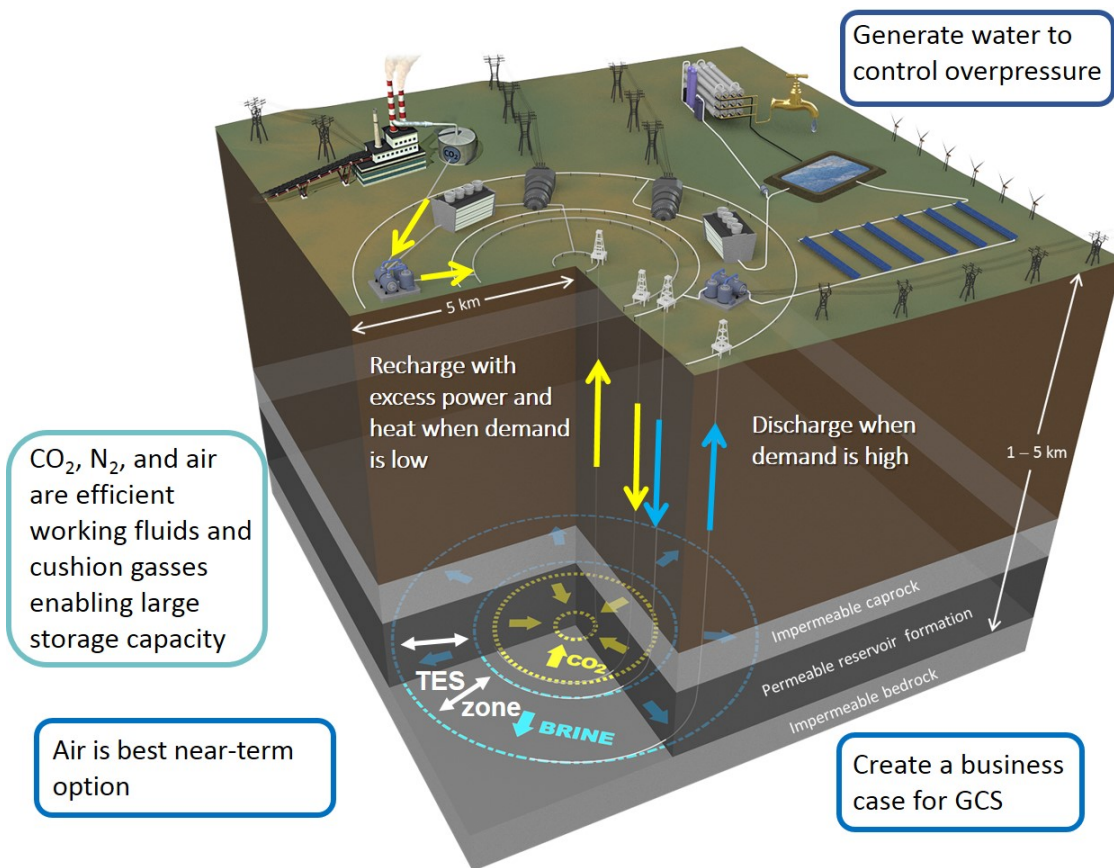

Fig. 3.14. An Earth Battery System with CO₂ is Shown

Unique Characteristics

The unique feature of nuclear geothermal energy storage is the ability to enable seasonal and multiyear energy storage—and with that capability assured generating capacity. The incremental cost of added heat storage capacity in many geologies is near zero. The primary cost of seasonal or multiyear storage is the cost of the heat. This characteristic creates the option of a strategic heat storage reserve—similar to strategic oil and natural gas storage reserves to guard against disruptions in fossil-fuel supply. In a low-carbon world those disruptions could be of biofuels (weather), hydrogen if imported, unexpected weather events such as multiyear droughts that limit hydroelectric output, and major weather events such as large hurricanes that result in large scale damage to wind production capacity. This also implies that such a storage system could obtain capacity payments because of the assured ability to generate electricity on demand. It is the only storage system that has equivalent assured capacity to a nuclear reactor or fossil fuel plant.

3.3. Choice of Heat Storage Technology

Technology Characteristics of Different Storage Systems

Different electricity markets have different constraints and requirements. On the production side, large-scale solar will depress prices at times of high solar input—a daily cycle. Large-scale wind is often on a multi-day cycle with coupled daily variations that impact production and thus prices. Electricity demand has a daily cycle, a weekly cycle (weekday and weekend), and a seasonal cycle. Each reactor thermal storage technology has its own characteristic (Table 3.2)—rate of charging and associated costs (\$/MWt), round-trip efficiency, cost of storage (\$/MWh), rate of discharge and cost of associated energy conversion (\$/MWe). The preferred storage technology will depend on the cost of the technology and on the specific market.

Table 3.2. Relative Storage Option Characteristics

Property	Accumulator	Latent Heat	Counter-Current	Cryogenic	Hot Rock	Geo-Thermal
Storage Time						
Hours	Yes	Yes	Yes	Yes	Yes	Yes
Weekly	?	?	?	?	Yes	Yes
Seasonal	No	No	No	No	No	Yes
Heat Input Method (Rate)	Direct Steam/Fast	Heat Exchanger (HX)/ Medium	Direct Steam/ Fast	HX/ Medium	HX/ Medium	Direct Steam/ Fast or HX
Output versus Input	Variable	Variable	Variable	High	Low	Low
Deployment Status	Near Term	Near Term	Mid Term	Mid Term	Mid Term	Longer Term
Capital Cost: Heat input	Very Low	Medium	Very low	High	Medium	Low or Medium
Capital Cost: Incremental Heat Storage	High (High Pressure)	Medium	High (High Pressure)	Medium	Very Low	Very Low
Capital Cost: Heat-to-Electric Output	Low to Medium	Low to Medium	Low to Medium	Low (Gas Turbine)	Low to Medium	Medium to High
Round Trip Efficiency	Medium	Medium	High	Medium	Medium	Low

The cost of heat input into a storage system depends on whether steam is the input or heat is transferred through a heat exchanger to a secondary fluid. Because of the cost of heat exchangers, storage systems with the option of direct steam input (accumulators, geothermal, etc.) will have an advantage in markets where the electricity price collapses to very low levels for limited periods of time—such as in some markets with solar price collapse. In those markets one wants to quickly charge the storage system while the price is low.

Several of the technologies (sensible heat, hot rock and geological) may be able to participate in capacity markets with assured capability to produce electricity when needed because of their low cost of incremental heat storage (\$/MWh). The ability of the other technologies to participate in electricity capacity markets will depend upon how capacity markets are defined—the length of time that electricity must be delivered. This is in contrast to almost all other storage technologies (batteries, most but not all pumped hydro) where the incremental energy storage costs are too large for this to be viable.

Much of the cost is associated with the heat to electricity conversion process. There are large incentives where possible to use the reactor turbine to produce added electricity—it is always operating and the incremental cost of capacity is low. This is an option on new plants but may or may not be an option for existing nuclear power plants.

Several heat storage technologies could be deployed in the next several years because the technology exists and has been deployed in other energy markets and deployment is primarily dependent upon engineering and projected economics in specific markets. This includes steam accumulators and sensible heat storage. Other storage technologies require significant research and development before large-scale deployment.

Matching Storage Options to Markets

Each heat storage technology has different characteristics such as rate of charging, round-trip efficiency, rate of discharge, cost to input energy into the system (\$/MWt), cost of storage (\$/MWh) and cost of converting heat to electricity (\$/MWe). As a consequence, the preferred option will depend upon the electricity market. The preferred heat storage system in a grid with large solar capacity and the need for daily energy storage will likely be different than a system with excess wind capacity and multiday cycles of low and high-priced electricity.

Heat storage cost structures are different from storage technologies such as batteries and most other electricity storage technologies. That impacts operations. Batteries and pumped hydro storage are expensive and for engineering reasons have peak electricity input rates to storage that are near peak rates of electricity output. As a consequence, the strategy (Fig. 3.15) is buy low-price electricity and sell only at peak electricity prices.

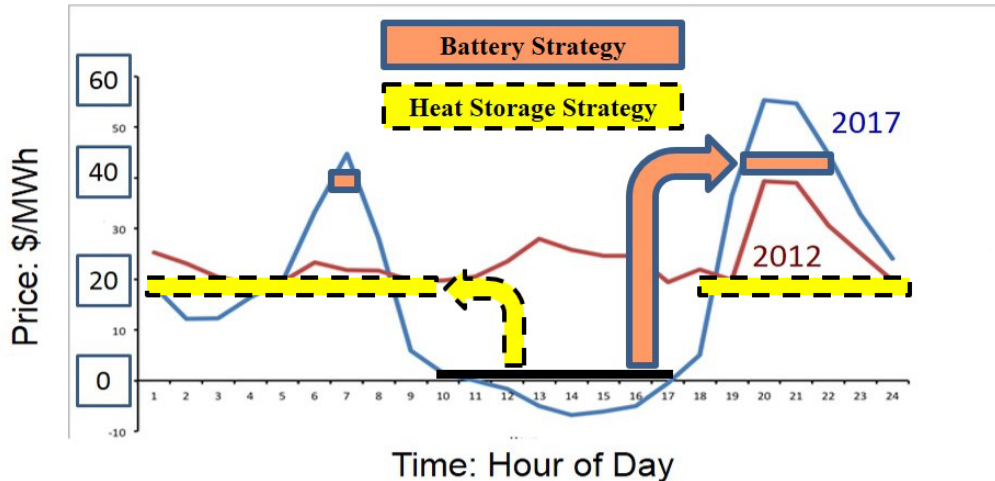

Fig. 3.15. Alternative Buy and Sell Strategies for Batteries (Sell Limited Hours) and Nuclear Heat Storage (Sell Many Hours) in California Electricity Market Shown in Fig. ES.1

Accumulators and some other heat storage technologies have very low costs for heat addition to storage with the cost of converting heat-to-electricity dependent upon whether the main nuclear turbine can be used or a stand-alone steam to electricity system is required. In a market with large-scale solar and existing plants the profitable strategy may be to send steam to storage 7 hours per day when prices are low and produce added electricity 17 hours per day. In effect (Varrin, Appendix C) the system would have very high steam rates (20 to 25% of plant output) into storage (low-cost part of system) and smaller peak electricity production rates (higher-cost part of system). When viewing such a nuclear plant as a black box, the addition of storage would appear to have increased its “base-load” capacity by less than 5% with the capability to ramp down power output at times of low electricity prices. Inside the plant the reactor is operating at full capacity all the time. That may enable an existing nuclear plant to reduce electric output by lowering reactor power and sending steam to storage.

None of these storage technologies have yet been coupled to a nuclear reactor for heat storage. Accumulators and sensible heat systems have been deployed with solar thermal power systems. The steam accumulator technology is deployable today followed by the sensible heat storage technologies and cryogenic heat storage. The other technologies require added research, development, and demonstration.

4. REGULATORY AND MARKET RULES

4.1. Nuclear Regulatory Commission

No heat storage system has been coupled to a nuclear reactor in the United States. However, a decade ago the Fort Calhoun Nuclear Power Plant [Gasper, Appendix C] investigated selling large quantities of steam to Cargill for corn milling and ethanol production. This included detailed engineering studies, cost evaluations and discussions with the Nuclear Regulatory Commission on what was required to extract steam before the high pressure turbine and sell heat to an industrial facility. A preliminary licensing evaluation determined that prior NRC approval for the transfer of steam to Cargill was not required. However, because this would have been the first steam transfer to an external customer from a reactor in the U.S., both the NRC and Ft. Calhoun felt a prior NRC review would have been desirable. The project was not implemented but went far enough to provide credible information on what is required to divert steam from a nuclear power plant and thus what is required for coupling heat storage to a PWR in the U.S. utility environment. Several utilities elsewhere in the world sell steam to local customers [IAEA, 2017].

4.2. Market Rules

The market rules are in transition and changes may be required for large-scale heat storage. Utility experience shows that changes can be made but it will take time to make the required changes. These rules are partly set by legislation, the Federal Energy Regulatory Commission (United States) and state Public Service Commissions (state governments).

The market rules were originally developed for an electricity grid with nuclear plants with low operating costs and fossil plants with high operating costs. We are now in a transition from low-capital-cost high-operating-cost fossil-fuel technologies to high-capital-cost low-operating-cost technologies (nuclear, wind, and solar). The addition of wind and solar results in large quantities of non-dispatchable electricity that changes the market structure. As a consequence, the rule sets are in a state of flux as regulators change rules to adjust to these changes.

There are several regulatory challenges. Heat storage implies the addition of potentially multiple-gigawatt energy storage systems. In this context it is similar to large hydro pumped storage facilities. In the U.S. utility environment there are several pumped storage facilities in deregulated markets but these are very few in number and no new such facilities have been built in many decades. The addition of such a technology may result in rule modifications—particularly those associated with market power. The second consideration is that different states have different rules—from fully deregulated markets to fully-regulated vertically-integrated utilities. There is not a rule set; there are 50 rule sets (state by state) with different regulatory structures.

5. COMMERCIALIZATION

5.1 Business Case

Commercialization requires a strong business case, available technology and appropriate institutional structures.

The business case [Sowder, Appendix C] is central but there are caveats. First, the business case for large-scale heat storage did not exist five years ago—it only appeared with the large-scale deployment of wind and solar that drives wholesale electricity prices to very low levels at certain times. Second, the electricity market and the market rules are changing rapidly thus that market case is improving with time but strongly dependent upon location. These changes include the development of capacity markets that are accessible by some of the heat storage technologies but not by most other storage technologies.

In terms of economics, a strong case exists that the economics are much better than batteries and other electricity storage options available to the utilities—the longer-term competition. However, the competition today in the United States is low-price natural gas—except where natural gas supply is limited by legal constraints or pipeline capacity. The lowest-cost options are likely to be options where stored heat goes back to the nuclear plant feed-water system or the turbine—minimizing storage system costs associated with converting heat to electricity. Heat storage built into an existing reactor where minor modifications allow larger power output of the main turbine-generator set (case by case evaluation) or a new reactor will have lower costs than a stand-alone heat storage and power generation system added to an existing reactor. The cost of incrementally increasing the size of the main turbine in a nuclear plant is much less than building a separate stand-alone turbine for a heat storage system.

The economics are sensitive to the number of storage cycles per year—doubling the number of cycles per year approximately cuts costs in half. That implies that the economics improve with increased deployment of wind and solar that result in more periods of very low electricity prices.

5.2. Hybrid Energy Systems

Reactor heat storage has major implications beyond the electricity sector. In hybrid energy systems heat from the reactor is used to provide electricity and steam to industry. Some nuclear reactors in Europe and Russia produce electricity and sell steam to industrial customers [IAEA, 2017]. The addition of storage has major economic and engineering implications for these hybrid systems.

The experience of the Fort Calhoun steam project [Gasper, Appendix C] shows that one of the barriers to exporting steam from nuclear reactors to industrial customers is assured steam delivery. If there is no storage, the industrial customer has to build into his system the capability to withstand rapid loss of steam supply if the reactor shuts down—either changes in process design, or rapid-start

alternative steam supplies. Heat storage provides time for the industrial customer to adjust if the reactor shuts down.

Heat storage has the potential to substantially improve the economics of hybrid systems. To meet demand the reactor operates at full power with variable steam to industry and electricity to the grid. Industry requires a continuous supply of steam to maintain operations so the industrial customer historically received priority with electricity production a second priority. If the system contains heat storage, some of the heat for industry can be produced when electricity prices are low allowing the reactor to produce only electricity when electricity prices are high with heat from storage delivered to industry at the same time. In effect, heat storage provides a method of transferring energy from the electric sector to the industrial sector at times of excess electricity production to the economic benefit of to both sectors.

The cost of heat storage for industrial customers is less than storing heat for production of electricity. Heat storage systems have three major components: (1) systems to move steam to storage, (2) the storage system and (3) the system to convert the stored heat back into electricity. For many of these storage systems, the most expensive component is the heat-to-electricity conversion system—the power cycle. For example, in a steam accumulator for industrial heat the cost is for the accumulator—there is no power cycle cost. If the user of stored heat is an industrial customer, one does not have the capability to produce peak electricity but one retains the capability to reduce electricity production while the reactor continues to operate at full capacity at times of low electricity prices.

Some of the storage systems may be able to reduce political and legal challenges associated with sales of steam to industrial customers. The Fort Calhoun-Cargill project [Gasper, Appendix C] was cancelled because of insurance company concerns about the legal liability of tritium leakage from the nuclear plant to the industrial customer where some of the steam was used to manufacture foodstuffs. Isolation heat exchangers and radiation detectors eliminate safety concerns. However, tritium can diffuse through metal heat exchangers and thus the concerns by insurance companies were about lawsuits. Tritium is made continuously in nature and found in all foods but the question is how does one prove the plant was not a source of tritium when tritium is found. The issue is the risk of legal liability.

Heat storage may address this two ways. It provides more time delay for confirming no significant tritium. Second, some of the systems use heat transfer oils to move heat to storage. Unlike water, hydrogen does not isotopically exchange with these organics; that is, if any tritium enters the system it will remain as tritium gas. Metallic tritium getters such as zirconium sponge can be put in oil systems to collect the tritium or any other hydrogen that diffuses into the system. These getters are chemically compatible with oil based heat transfer agents but not water.

5.3. Next Step Forward

The near-term heat storage options are at the point where a demonstration project is required. Such a demonstration will have several goals—some of them common to all heat storage technologies.

- *Institutional.* Previous experience with the NRC and markets (FERC and Public Service Commissions) indicate thermal storage at a reactor will couple with the electric grid. However, a demonstration project is required to demonstrate this and work through the permitting and regulatory process.
- *Technology demonstration.* The chosen technology must be demonstrated at a scale sufficient to allow scale-up to full size in a utility environment. Given the characteristics of the technology, there is the option to demonstrate at scale.
- *Economics.* There are the economics of the storage system but there are also the larger economics of the entire system. A demonstration project will provide the first numbers for both. This includes system upgrades such as transmission.

There are large economic incentives for near-term demonstrations by 2020. The rapidly changing markets partly driven by wind and solar subsidies have resulted in loss of revenue and shutdown of some nuclear plants with more plants in danger of closing (Haratyk 2017). Such reactor shutdowns (1) have serious negative impacts on local communities, (2) increase greenhouse gas emissions, (3) reduce dispatchable electricity capacity and (4) make the United States increasingly dependent upon a single fuel (natural gas) with all the risks associated with less diversity of energy supply. Heat storage is one of the few near-term options that if successfully demonstrated could have a major impact in less than a decade to improve nuclear plant revenue while creating an enabling technology for a low-carbon electricity grid. Because of the large potential impact, it is an option where a public-private partnership should be considered.

There are large incentives for government support of long-term public-private partnership for demonstration projects—particularly for the more advanced options where significant R&D is required. This is particularly true for nuclear geothermal systems that create the option of a strategic energy reserve—equivalent to a strategic petroleum reserve. Strategic reserves are a governmental function. A strong public interest case exists. Energy is a major business and a major fraction of the economy. A break-through in lowering energy storage costs has large economic implications and increases the long-term viability of an economic low-carbon electricity grid. While the technologies herein are for LWRs, many of these heat storage technologies apply to other nuclear reactor systems and solar thermal power systems.

6. CONCLUSIONS

The electricity market is changing with times of very low wholesale electricity prices occurring with increased frequency. That change creates the economic incentives for energy storage to enable variable electricity production with base-load reactor operations. This energy storage market did not exist five years ago. The economic incentives are increasing rapidly with time.

There are two classes of energy storage devices: (1) storing electricity (a form of work) using hydro pumped storage, batteries and other such technologies or (2) storing heat. Nuclear reactors produce heat and thus have the option to store heat for variable electricity production. Heat storage is generally an order of magnitude less expensive than work storage [Lund, 2016; Johnson 2017].

There are multiple heat storage options, some that could be deployed very quickly (steam accumulators, sensible heat, etc.) and others that will require significant R&D. The near-term options have been deployed with solar power systems in utility environments to better match production with demand. The preferred storage option depends upon the economics of the storage technology and the electricity market—when there are high electricity prices and when there are low electricity prices. It is unlikely that a single heat storage technology will be optimum given different electricity markets.

The business case for deployment of thermal energy storage exists in a few markets and is expected to exist in many more markets going forward in time. The economics are favorable relative to electricity storage options (pumped hydro and batteries) but the near-term competition in the United States is with natural gas for variable electricity production. That economic case for existing reactors depends upon the market those reactors are in and details of plant design that determine the costs of adding heat storage to a specific plant—there is no single answer. Restrictions on use of fossil fuels or a carbon tax would be expected to dramatically improve the business case for nuclear systems with heat storage.

Finally, there is a need for demonstration projects to test technologies and address various institutional issues.

7. REFERENCES

Bindra, H., et al., 2013. "Thermal Analysis and Exergy Evaluation of Packed Bed Thermal Storage Systems." *Applied Thermal Engineering* 52, 255-263.

Bindra, H., J. Edwards, D. Gould, 2017. *Methods and Systems for Thermal Energy Storage and Recovery*, U.S. Patent Application No. 62/339,576 (International Patent Application No. PCT/US2017/033566)

Birnbaum, J., M. Eck, M. Fichtner, T. Hirsch, D. Lehmann and G. Zimmermann, 2010, "A Direct Steam Generation Solar Power Plant With Integrated Thermal Storage," *Journal of Solar Energy Engineering*, . **132** (3), p. 31014.

Bisett, S., A. LaPortin and E. Schneider, June 11-15, 2017, "Steam Accumulator Storage Integration into a Nuclear Power Plant," *Transactions of the American Nuclear Society*, San Francisco.

Buscheck, T. A., et al., 2014, "Integrating CO₂ Storage with Geothermal Resources for Dispatchable Renewable Electricity", *Energy Procedia*, **63**, 7619-7630.

Buscheck, T. A., December 2015, "Earth Battery," *Mechanical Engineering*, **137**,
https://www.google.com/?gws_rd=ssl#q=Earth+Battery+ASME+Mechanical+Engineering+Magazine.

Buscheck, T.A., J. M. Bielicki, T. A. Edmunds, Y. Hao, Y. Sun, J. M. Randolph, and M. O. Saar, 2016. "Multifluid Geo-energy Systems: Using Geologic CO₂ Storage for Geothermal Energy Production and Grid-scale Energy Storage in Sedimentary Basins", *Geosphere*, **12** (3), doi:10.1130/GES01207.1.

Buscheck, T.A., J. M. Bielicki, J. B. Randolph, J.B., 2017. CO₂ Earth Storage: Enhanced Geothermal Energy and Water Recovery and Energy Storage, *Energy Procedia*.

Chen, H., Y. L. Ding, T. Peters, and F. Berger, 2007, *A method of storing energy and a cryogenic energy storage system*, WO 2007/096656

Ding, Y. L. Y. Li, Y. Jin, D. Li, G. Leng, F. Ye, Z. Sun, H. Cao, and G. Qiao, 2013, *A Peak-shaving Method for Nuclear Power Plants Through Integration with Cryogenic Energy Storage.*, CN201310279616.2.

Ding, Y.L. Y. Li, and J. Radcliffe, 2016, “Liquid Air Energy Storage.” *Storing Energy*, Trevor Letcher eds., Elsevier BV, ISBN 9780128034408.

Edwards, J. H., D. Franken, H. Bindra, and P. Sabharwall, November 6-10, 2016, “Packed Bed Thermal Storage for Compact Light-Water Cooled Small Modular Reactors”, *Transactions of the American Nuclear Society Meeting*, **115**, Las Vegas, NV

Edwards, J., H. Bindra, and P. Sabharwall, 2016, “Exergy Analysis of Thermal Energy Storage Options with Nuclear Power Plants,” *Annals of Nuclear Energy*, **96**, 104-111.

Fitzhugh, R. L., J. D. Richards, J. M. Schaumann, and M. J. Memmott, April 17-20, 2016, “Preliminary Design of a Thermal Energy Storage System for a Light Water reactor,” *International Congress on Advanced Nuclear Power Plants (ICAPP 2016)*, San Francisco.

Frick, K., J. M. Doster and S. M. Bragg-Sitton, June 11-15, 2017 (a), “Control Strategies for Coupling Thermal Energy Storage Systems with Small Modular Reactors”, *Trans. American Nuclear Society*, San Francisco.

Frick, K., J. M. Doster and S. M. Bragg-Sitton, October 29-November 27, 2017 (b), “Design of a Sensible Heat Peaking Unit for Small Modular Reactors”, *Trans. American Nuclear Society*, Washington D.C.

Forsberg, C., June 24-28, 2012, “Gigawatt-Year Nuclear-Geothermal Energy Storage for Light-Water and High-Temperature Reactors, *Proc. of International Congress on Advanced Nuclear Power Plants (ICAPP 2012)*

Forsberg, C., 2013, “Hybrid Systems to Address Seasonal Mismatches Between Electricity Production and Demand in Nuclear Renewable Electricity Grids,” *Energy Policy*, **62**, 333-341.

Forsberg, C., D. Curtis, and D. Stack, April 2017a “Light-water Reactors with Crushed-Rock Thermal

Storage for Industrial Heat and High-Value Electricity,” *Nuclear Technology*, **198**, <http://dx.doi.org/10.1080/00295450.2017.1294426>

Forsberg, C., D. C. Stack, D. Curtis, G. Haratyk and N. A. Sepulveda, July 2017. “Converting Excess Low-Priced Electricity into High-Temperature Stored Heat For Industry and High-Value Electricity Production,” *Electricity Journal*.

Gilli, P. V. and K. Fritz, October 5-9, 1970, “Nuclear Power Plants with Integrated Steam Accumulators for Load Peaking” IAEA Symposium on Economic Integration of Nuclear Power Stations in Electric Power Systems, Vienna, WB-KE-2015.

Gilli, P. V. and G. Beckman, August, 1973, “Steam Storage Adds Peaking Electricity Capacity to Nuclear Plants,” *Energy International*.

Han, W.; J. Hongguang, S. Jianfeng; L. Rumou; and W. Zhifeng, Oct. 2009. “Design of the First Chinese 1 MW Solar-Power Tower Demonstration Plant.” *Int. J. Green Energy*. Vol. 6, no. 5, pp. 414–425.

Haratyk, G., *Nuclear Asset Shutdown Under Uncertainty*, September 2017, PhD Thesis, Department of Nuclear Science and Engineering, Massachusetts Institute of Technology, Cambridge, Massachusetts.

Highview Power Storage, 2017, *Liquid Air Energy Storage (LAES)*. <http://www.highview-power.com/>

Hirsch, T., J. Feldhoff, K. Hennecke & R. Pitz-Paal, 2014, “Advancements in the Field of Direct Steam Generation in Linear Solar Concentrators—A Review,” *Heat Transfer Engineering*, **35** (3), pp. 258–271.

Harvey, A. L., July, 2017, “The Latest in Thermal Energy Storage”, *Power*, **161** (7), 50-52.

International Atomic Energy Agency, 2017, *Opportunities for Cogeneration with Nuclear Energy*, NP-T-4.1, Vienna, Austria.

Johnson, S. C., M. E. Webber and J. L. Coleman, June 11-15, 2017, “An Evaluation of Energy Storage Options for Nuclear Power”, *Trans. American Nuclear Society*, San Francisco.

Joskow, P. L., 2008. “Capacity Payments in Imperfect Electricity Markets: Need and Design”, *Utility Policy*, **16**, 159-170.

G. E. King, 2012, *Hydraulic Fracturing 101: What Every Representative, Environmentalist, Regulator, Reporter, Investor, University Researcher, Neighbor and Engineer Should Know About Estimating Frac Risks and Improving Rack Performance in Unconventional Gas and Oil Wells*, SPE 152596, Society of Petroleum Engineers.

Kulhanek, M., C. W. Forsberg, and M. J. Driscoll, January 2012. *Nuclear Geothermal Heat Storage: Choosing the Geothermal Heat Transfer Fluid*, MIT-NES-TR-016, Massachusetts Institute of Technology, Cambridge, Massachusetts.

Kuravi, S. et al, 2013, “Thermal Energy Storage Technologies and Systems for Concentrating Solar Power Plants (Review),” *Progress in Energy and Combustion Science*, **39**, 285-319

Laing, D., C. Bahl, T. Bauer, D. Lehmann & W. Steinmann, 2011, “Thermal energy storage for direct steam generation,” *Solar Energy*, **85** (4), pp. 627–633.

Lane, R. E. III, *Modeling and Integration of Steam Accumulators in Nuclear Steam Supply Systems*, MS Thesis, University of Texas at Austin, December 2016.

LaPotin, A. and E. Schneider, November 2016, “An Economic Model of a Steam Accumulator Storage System for Nuclear Power Plants”, *Transactions of the American Nuclear Society*.

Lee, Y., C. Forsberg, M. Driscoll, and B. Sapie, June 13-17, 2010. “Options for Nuclear Geothermal Gigawatt-Year Peak Electricity Storage Systems, *Proc. of ICAPP’10*, San Diego.

Lee, Y., June 2011. *Conceptual Design of Nuclear-Geothermal Energy Storage Systems for Variable Electricity Production*, MS Thesis, Department of Nuclear Science and Engineering, Massachusetts Institute of Technology.

Li, Y., H. Cao, S. Wang, D. Li, X. Wang, and Y. Ding, 2014, “Load shifting of nuclear power plants using cryogenic energy storage technology.” *Applied Energy*, **113** p. 1710–1716.

Lund, H. et al, 2016, “Energy Storage and Smart Energy Systems”, *International Journal of Sustainable Energy Planning and Management*, **11**, 3-14.

Mann, W. N. 2017. *Construction of Hybrid Nuclear Thermal Energy Storage Systems under Electric Market Uncertainty*, MS Thesis, University of Texas at Austin

Medrano, M., A. Gil, I. Martorell, X. Potau & L. F. Cabeza, 2010, “State of the art on high-temperature thermal energy storage for power generation. Part 2—Case studies,” *Renewable and Sustainable Energy Reviews*, **14** (1), pp. 56–72.

Moon, H and S. J. Zarrouk, November 19-21, 2012. “Efficiency of Geothermal Power Plants: a Worldwide Review,” *Proc. New Zealand Geothermal Workshop*, Auckland, New Zealand.

National Renewable Energy Laboratory, 2017. “Concentrating Solar Power Projects.” [Online]. Available: <https://www.nrel.gov/csp/solarpaces/index.cfm>

Schmidt, O., A. Hawkes, A. Gambhir, and I Staffell, July 10, 2017. “The Future Cost of Electrical Energy Storage Based on Experience Rates,” *Nature Energy*, **2**, Article 17110

Steinmann, W.D. and M. Eck, 2006, “Buffer storage for direct steam generation,” *Solar Energy*, **80** (10), pp. 1277–1282.

Westinghouse Electric Company LLC, 2016, *Nuclear Energy Storage*.

Zunft, S., S. Freund, and E. M. Schlichtenmayer, November 19-21, 2014, “Large-Scale Electricity Storage with Adiabatic CAES – The Adele-Ing Project”, *Energy Storage Global Conference*, Paris.

Appendix A:
Workshop Agenda

Final Agenda

Light Water Reactor Heat Storage for Peak Power and Increased Revenue Focused Workshop on Near-Term Options

June 27-28, 2017

Salon T, Samberg Conference Center, Building E52 7th floor, MIT Campus
Cambridge, Massachusetts

Goals

The workshop goals are to define and understand the market, regulatory, and technical options for coupling heat storage to existing and future LWRs with recommendations for the path forward to improve LWR economics. The emphasis is using the stored heat produced at times of low electricity prices for electricity production at times of high electricity prices with a secondary consideration for off-site heat sales (different regulatory constraints). The options to be discussed are primarily associated with those that divert steam from the LWR to storage while maintaining the main turbine on line at minimum load to allow rapid return to full power providing variable electricity to the grid. The power plant goal is increased annual revenue with a reactor that operates at full load and does not “see” the variable electricity output from the plant site. The electricity system goal is low-cost low-carbon dispatchable electricity.

Path Forward

A workshop proceedings with conclusions will be prepared and issued for public distribution. There is also a workshop website with added information for participants.

Workshop Agenda

Tuesday: June 27, 2017

8:15: Coffee, Tea, and pastries

9:00—12:00 Morning Session: Economics and Systems Constraints (with break)

1.1. Introduction and Welcome

1.2. Changing Electricity Markets (J. Parsons, MIT Sloan School; G. Haratyk, J. Jenkins)

1.3. Nuclear Plant Technical Storage Constraints: Limits of turndown of existing and future steam turbines in nuclear plants, allowable ramp rates and other constraints (J. Wooten, Westinghouse)

1.4. Recent Experience: The Fort Calhoun-Cargill Proposed Steam Sales and Lessons Learned (J. Gasper, Omaha Public Power/Fort Calhoun (retired))

1.5. Electricity storage: Status and Limitations in a Low-Carbon World (S. Brick, Clean Air Task Force)

12:00-1:15 Lunch with Talk: Firebrick Resistance Heated Energy Storage: The Other Thermal Storage Option (C. Forsberg, MIT)

1:15-5:00 Afternoon Session (with Breaks): The Technology Options and Status

2.1. Turbine hall modifications: Hot feedwater storage and other options (R. Varrin: Dominion Eng.)

2.2. Steam accumulators: Direct hot water/steam storage (E. Schneider/N. Mann, U. of Texas)

2.3. Heat storage (oil, salt, etc.) in secondary media (M. Doster, North Carolina State)

2.4. Westinghouse heat storage studies (C. Stansbury, Westinghouse)

2.5. Cryogenics, Liquid air storage (Y. Ding, U. of Birmingham)

2.6. Counter-current solid heat storage (H. Bindra, Kansas State University)

2.7. Crushed Rock Storage (N. McLauchlan, MIT)

2.8. Geothermal (C. Forsberg, MIT; T. Buscheck, LLNL)

6:00-7:00 Reception

7:00-9:00 Dinner with Talk: The Need for Dispatchable Electricity in a Low-Carbon World (R. Lester, Associate Provost MIT, Chair National Academies Board on Science, Technology and Economic Policy)

Wednesday June 28, 2017

8:15 Coffee, Tea and Pastries

9:00-12:00 Path Forward (Talks and panels) with break

3.1. Electricity Market Characteristics vs. Choice of Thermal Storage Options (D. Curtis, MIT).

3.2. Regulatory Challenges: Market Rules for Grid, Anti-trust, Other Considerations. (T. Krall, Exelon)

3.3. Development and Demonstration Strategies: Talks and Panel Session (A. Sowder: EPRI, J. Jurewicz: Exelon, C. Stansbury: Westinghouse)

12:00-2:00 Lunch (bag lunch: End of Workshop: Informal Discussions)

Appendix B:

Workshop Participants, and Speaker Biographies

Workshop Participants

<i>Name</i>	<i>Affiliation</i>
Bindra, Hitesh	Kansas State
Boardman, Richard	INL
Brick, Stephen	Clean Air Task Force
Buongiorno, Jacopo	MIT
Buscheck, Tom	LLNL
Ding, Yulong	U. of Birmingham, UK
Doster, Joseph Michael	North Carolina State
Farda, Anthime	CEA
Ferroni, Paolo	Westinghouse
Forsberg, Charles	MIT
Gasper, Joe	Ft. Calhoun
Greenwood, Michael Scott	ORNL
Grichnik, Michael J.	Caterpillar
Hanus, Eric	CEA
Harrison, Thomas J.	ORNL
Jurewicz, Jacob M	Exelon
Kito, Kazuaki	Hitachi-GE Nuclear
Krall, Timothy J.	Exelon
Lassiter, Joseph	Harvard
Lester, Richard	MIT
Loewen, Eric	General Electric
Mann, Neal	U. of Texas
McDaniel, P.K.	New Mexico
McGrail, B.P. (Pete)	PNNL
Memcott, Matthew	BYU
Nichol, Marcus	NEI
Nielsen, Robert	Exxon
O'Sullivan, Francis Martin	MIT
Parsons, John	MIT
Petti, Dave	INL
Sabharwall, Piyush	INL
Sowder, Andrew	EPRI
Stansbury, Cory A.	Westinghouse
Todreas, Neil	MIT
Varrin, Robert	Dominion Eng
Walter, Josh	Terrapower
Wilson, Andy	Open University, UK
Wooten, Joseph E.	Westinghouse
Yetisir, Metin	Canadian National Laboratory
<i>students</i>	
Champlin, Patrick	MIT
Curtis, Daniel	MIT
Dawson, Karen	MIT

Fears, Kendall	MIT
Haratyk, Geoffrey	MIT
Jenkins, Jesse David	MIT
McLauchlan, Nathaniel Ross	MIT
Poujol, Matthieu	MIT
Stack, Daniel	MIT

Workshop Speakers

Light Water Reactor Heat Storage for Peak Power and Increased Revenue

Bindra, Hitesh (Kansas State University)

Brick, Steve (Clean Air Taskforce)

Buscheck, Tom (Lawrence Livermore National Laboratory)

Curtis, Daniel (MIT)

Ding, Yulong (University of Birmingham. United Kingdom)

Doster, Michael J. (North Carolina State University)

Forsberg, Charles (MIT)

Gasper, Joe (Omaha Public Power/Fort Calhoun (retired))

Haratyk, Geoffrey (MIT)

Jenkins, Jesse (MIT)

Jurewicz, Jake (Exelon Corporation)

Krall, Timothy (Exelon Corporation)

Lester, Richard (MIT)

Mann, Neal (University of Texas, Austin)

McLauchlan, Nate (MIT)

Parsons, John (MIT)

Sowder, Andrew (Electric Power Research Institute)

Stansbury, Corry (Westinghouse)

Varrin, Robert (Dominion Eng.)

Wooten, Joe (Westinghouse)

Speaker Biographies

Light Water Reactor Heat Storage for Peak Power and Increased Revenue

Bindra, Hitesh (Kansas State University)

H. Bindra is an Assistant Professor at Kansas State Univ. His research focus is on thermohydraulics of advanced nuclear reactors and energy systems. He has developed thermal energy storage for various applications ranging from combined cycle power plants to building heating.

Brick, Steve (Clean Air Taskforce)

Steve Brick has worked for more than forty years at the intersection of energy and environmental policy; his expertise includes utility regulatory policy, energy economics, energy technology assessment and air pollution control policy and economics. Since 2009 he has been a Senior Fellow in Climate and Energy at the Chicago Council on Global Affairs and Senior Advisor in Technology and Policy at the Clean Air Task Force. From 2005 to 2009 Mr. Brick served as the manager of the environment program for the Joyce Foundation in Chicago.. Other experience includes director of environmental affairs for PGE National Energy Group, science and policy director for the Clean Air Task Force, and co-founder and vice president of the energy consulting firm MSB Energy Associates. He received his BA and MS from the University of Wisconsin-Madison.

Buscheck, Tom (Lawrence Livermore National Laboratory)

Tom Buscheck is an earth scientist in the Atmospheric, Earth, and Energy Division at Lawrence Livermore National Laboratory. He received his B.S. in Civil Engineering from Lafayette College and his M.S. and Ph.D. in Civil and Geological Engineering from the University of California at Berkeley. His research interests involve multiphase heat and mass flow in porous media, with application to geologic radioactive waste isolation, geologic CO₂ storage, geothermal energy, and energy storage.

Curtis, Daniel, (MIT)

Daniel Curtis is a PhD student in the Department of Nuclear Science and Engineering. He is working on understanding heat storage options associated with LWRs.

Ding, Yulong (University of Birmingham. United Kingdom)

Yulong Ding is founding Chamberlain chair of Chemical Engineering and Royal Academy of Engineering industrial Chair of Cryogenic Energy Storage, and the founding Director of the Birmingham Centre for Energy Storage at the University of Birmingham (UoB), UK. His current research focuses on thermal and cryogenic energy storage. He is an inventor of the liquid air energy storage technology and led the initial stage of the technology development.

Doster, Michael J. (North Carolina State University)

J. Michael Doster is the Alumni Distinguished Undergraduate Professor of Nuclear Engineering at North Carolina State University. His research interests include: Reactor systems simulation and dynamics, Deployment and control strategies for Small Modular Reactors in Nuclear Hybrid Energy Systems including Thermal Energy Storage Systems.

Forsberg, Charles (MIT)

Charles Forsberg is a Senior Research Scientist in the Department of Nuclear Science and Engineering at MIT. Before joining the department he was a Corporate Fellow at Oak Ridge National Laboratories. His research interests include heat storage coupled to LWRs and high temperature reactors. He leads the Fluoride-salt-cooled High Temperature Reactor project that is a joint effort of MIT, the University of California at Berkeley, the University of Wisconsin and the University of New Mexico.

Gasper, Joe (Omaha Public Power/Fort Calhoun (retired))

Joe Gasper received his Ph.D. (Nuc. Eng.) from Iowa State and MBA from University of Nebraska. He retired from OPPD in 2010 as Manager of Design Engineering. In 2011 he returned to OPPD as consultant to lead the Ft. Calhoun response to Fukushima with major emphasis on Missouri River flood modeling, finally really retiring in fall 2016. He was the Manager of Major Projects at the time OPPD was exploring the cogeneration project with Cargill.

Haratyk, Geoffrey (MIT)

Geoffrey Haratyk is a PhD student and Research Assistant in the Department of Nuclear Science and Engineering at MIT. His research focuses on the economics of nuclear power in restructured electricity markets.

Jenkins, Jesse (MIT)

Jesse Jenkins is a PhD candidate at MIT's Institute for Data, Systems, and Society and a research assistant at the MIT Energy Initiative's Electric Power Systems Low Carbon Research Center. Jesse studies electric power sector economics, operations, regulation and policy, with a focus on two overarching trends transforming the electricity sector: the transition to zero-carbon power systems and the proliferation of distributed energy resources.

Jurewicz, Jake (Exelon Corporation)

Jake Jurewicz is a senior analyst in Exelon's Corporate Strategy group, responsible for developing Exelon's strategic plan and tracking industry trends in the energy and utility sectors. His focus resides largely in partnered research and development, in which he serves as technical liaison to universities, national labs, EPRI, and various companies.

Krall, Timothy (Exelon Corporation)

Timothy Krall is the Director, Business Initiatives and Analysis. Tim leads the strategic development, coordination, analysis, and implementation of Corporate and GenCo related initiatives. Tim joined Exelon in 1997 and has held various roles with Exelon. He most recently worked at PECO focusing on analytics and project management of strategic initiatives. Prior to that, he held roles in trading including energy and commodity trader and Midwest portfolio manager, and manager of various analytical and operational functions.

Lester, Richard (MIT)

Richard Lester is Associate Provost and Japan Steel Industry Professor of Nuclear Science and Engineering at MIT. Before becoming Associate Provost he served as Head of the MIT Department of Nuclear Science and Engineering. He is currently Chair of the National Academies Board on Science, Technology, and Economic Policy.

Mann, Neal (University of Texas)

Neal Mann is a Ph.D. student in the Nuclear and Radiation Engineering Program in the Department of Mechanical Engineering at the University of Texas at Austin. As part of Prof. Erich Schneider's research group, he models the economics of novel thermal energy storage systems coupled to nuclear power plants. His master's thesis modeled the success of steam accumulator retrofits to nuclear power plants in Texas under uncertain market conditions. He is currently an intern at Idaho National Laboratory under Dr. Piyush Sabharwall.

McLauchlan, Nate, (MIT)

Ensign Nate McLauchlan is a second year master's student in MIT's Technology and Policy Program with a bachelor's in chemistry from the US Naval Academy. He is developing and evaluating the concept of hot rock storage.

Parsons, John (MIT)

John Parsons is a member of the Finance Group at the MIT Sloan School of Management. Past participant in the MIT Nuclear Fuel Cycle study and current participant in the MIT Future of Nuclear study. He was a recent visiting scholar at FERC and has worked 30+ years in economics of energy and the environment.

Sowder, Andrew (Electric Power Research Institute)

Andrew Sowder is a Technical Executive in the Advanced Nuclear Technology program at the Electric Power Research Institute (EPRI). He leads EPRI's strategic program on advanced nuclear energy systems. Prior to joining EPRI, Andrew served as a physical scientist and foreign affairs officer at the U.S. Department of State addressing international nuclear safety and security issues. He received a B.S. in Optics from the University of Rochester and a Ph.D. in environmental nuclear engineering from Clemson University. Currently, he is a member of the American Nuclear Society's Standards Board and Chair of the Fuel Cycle and Waste Management Division.

Stansbury, Corry (Westinghouse)

Cory Stansbury has been with Westinghouse Electric for 9 years and has led the balance of plant systems/equipment design for Westinghouse Small Modular Reactor and now the Lead Fast Reactor. He is also the lead for Westinghouse Energy Storage investigations and system design. He is deeply involved in plant economic modeling for Westinghouse as well as energy policy with the American Nuclear Society.

Varrin, Robert D., Jr. (Dominion Engineering)

Dr. Varrin (Bob) is a Principal Engineer and Principal Officer at Dominion Engineering, Inc. (DEI) in Reston, VA. He received his BSE from Princeton University and his PhD from the University of Delaware, both in chemical engineering. Since 1980, he has worked in the nuclear power industry. His primary areas of support are in plant operations and maintenance, thermal-fluids, fuel performance, water chemistry and corrosion. He has worked on site at over 100 nuclear plants in the US, Canada, France, Spain, Korea and Japan. He has authored over 300 reports and publications, and holds more than 25 patents in the fields of nuclear power, photovoltaics and semiconductor processing.

Wooten, Joe (Westinghouse)



Joe Wooten has been with Westinghouse for 13 years doing nuclear plant thermal efficiency, hydraulic analysis, and AP1000 design work, mostly assisting with the I&C and BOP design groups. He has over 37 years experience in the nuclear field starting out at Comanche Peak before continuing on at Dresden and Davis-Besse plants before coming to Westinghouse in 2004.

Appendix C:
Workshop Presentations

Table of Contents for Presentations

<i>Page</i>	<i>Title</i>	<i>Author/Affiliation</i>
C-3	1.1. Introduction	C. Forsberg, MIT
C-6	1.2. Changing Electricity Markets	J. Parsons, MIT Sloan School; G. Haratyk, J. Jenkins
C-12	1.3. Nuclear Plant Technical Storage Constraints: Limits of turndown of existing and future steam turbines in nuclear plants, allowable ramp rates and other constraints	J. Wooten, Westinghouse
C-15	1.4. Recent Experience: The Fort Calhoun-Cargill Proposed Steam Sales and Lessons Learned	J. Gasper, Omaha Public Power/Fort Calhoun (retired)
C-19	1.5. Electricity storage: Status and Limitations in a Low-Carbon World	S. Brick, Clean Air Task Force
C-23	1.6 Firebrick Resistance Heated Energy Storage: The Other Thermal Storage Option (Lunch Talk)	C. Forsberg, MIT
C-30	2.1. A Case Study for Load Following with Heat Storage at an Existing LWR	R. Varrin, Dominion Engineering Corp.
C-34	2.2. Steam accumulators: Direct hot water/steam storage	E. Schneider/N. Mann, U. of Texas
C-39	2.3. Heat storage (oil, salt, etc.) in secondary media	M. Doster, North Carolina State
C-42	2.4. Westinghouse heat storage investigations	C. Stansbury, Westinghouse
C-44	2.5. Cryogenics, Liquid air storage	Y. Ding, U. of Birmingham
C-48	2.6. Counter-current solid heat storage	H. Bindra, Kansas State University
C-53	2.7. Atmospheric-Pressure Crushed-Rock Storage	N. McLaughlan, MIT
C-57	2.8. Geothermal Heat Storage	
C-57	2.8.a Nuclear Geothermal Heat Storage	C. Forsberg, MIT
C-60	2.8.b Earth Battery	T. Bushneck, LLNL
C-63	3.1. Electricity Market Characteristics vs. Choice of Thermal Storage Options	D. Curtis, MIT
C-68	3.3. Development and Demonstration Strategies	A. Sowder, EPRI

Session I
Economics and Systems Constraints

 Massachusetts Institute of Technology
  Idaho National Laboratory
  Exelon

Light Water Reactor Heat Storage for Peak Power and Increased Revenue

Workshop on Markets, Options, and Constraints



Cryogenic Air
High/Low 500W 1500th Demonstration Plant



Latent Heat Storage
(Molten Salt) Unit



Steam Accumulator

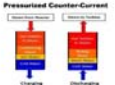

Pressurized Counter-Current

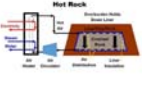

Hot Rock



Nuclear Geothermal

1

2

Welcome

- Thanks to Sponsors/Speakers
- Introductions
- Workshop Goals
 - Understand options
 - **Begin the process to define path forward**
- Proceedings will be available

 Massachusetts Institute of Technology

2

No Change In Energy Policy for 300,000 Years, Throw a Little Carbon on the Fire



➔



Cooking Fire
Natural-Gas Combined Cycle

Low Capital-Cost Power Systems: Economic at Part Load

3

Nuclear, Wind, and Solar Are High-Capital-Cost Low-Operating-Cost Technologies





Must Operate Near Full Capacity for Economic Energy

 Massachusetts Institute of Technology

4

Nuclear Energy Did Not Change Fossil Fuel Energy Policy or the Market

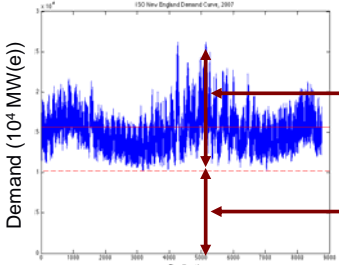
New England Electricity Demand Over One Year



150 New England Demand Curves, 2007

- Low-capital-cost High-operating-cost fossil plants for variable energy production
- High-capital-cost Low-operating-cost nuclear plants for base-load

Time (hours since beginning of year)

5

If No Fossil Fuels Because of Concerns About Climate Change, What Is the Replacement For Variable Electricity Production?

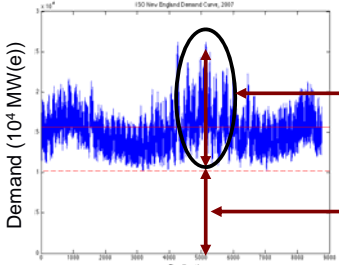

150 New England Demand Curves, 2007

Variable Electricity Market

Base-load Electricity Market

Time (hours since beginning of year)

6

If Add Wind or Solar, Base-Load Electricity Demand May Disappear: The California Duck Curve

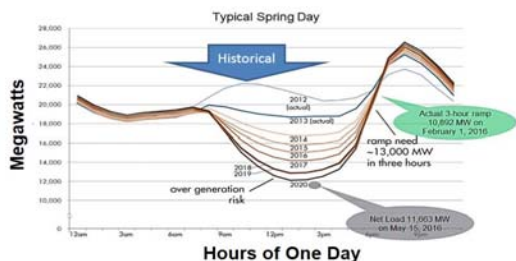

Solar Eliminates Mid-Day Demand For Other Electricity Sources But Need More Variable Power⁷

Impact of Large Solar on Electricity Prices California Sunday—Real Data

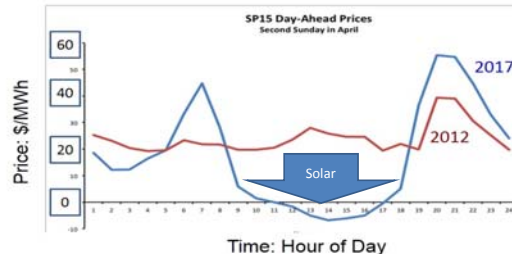

Market Changes in Last Three Years

Implications of the Duck Curve

- Wasted resources—producing something nobody values
- Price collapse occurs with large-scale deployment of any high-capital-cost low-operating-cost technology. Shows up when X% total electricity from Y technology
 - 15% Solar
 - 30% Wind
 - 70% Nuclear (France operates LWRs part load)

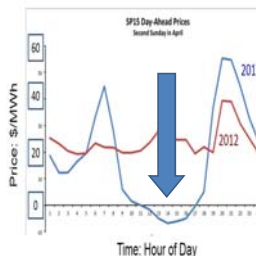

LWR Heat Storage Solution to Duck Curve Boost Revenue By Selling When Higher Prices



Nuclear Power Strategies for Variable Power to Electricity Grid and Industry

- Nuclear power is capital intensive so economic incentive to operate reactors at full capacity
- **Nuclear reactors produce heat, not electricity**
 - Nuclear power cycles convert heat to electricity
 - Heat storage 10 to 50 times less costly than storing electricity (pumped hydro, batteries, etc.)
 - Use heat storage for the competitive edge

LWR Heat Storage Strategy Minimum Change in Existing and New Plants

New T-junction needed after steam generator outlet.

Steam to storage when low prices

Turbine at Minimum load

Stored heat to electricity when high prices

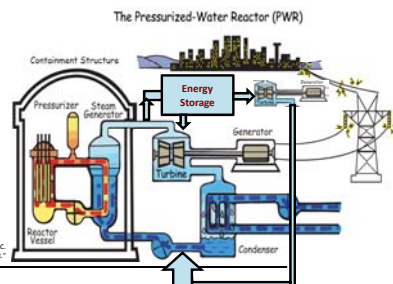

Adapted from US NRC
Animated Images of Pressurized Water Reactors

Questions for Workshop

- The Market
 - Where Going
 - What Market Rules Must Change (Designed for fossil-nuclear world that does not exist)
- LWR Constraints
- Heat storage
 - Technologies
 - Economics (Matching market to technology)
- **How to get from here to there—Economically Viable Variable Electricity from Base-Load LWRs**

CHANGING ELECTRICITY MARKETS



JOHN PARSONS (Sloan) GEOFFREY HARATYK (NSE),
 JESSE JENKINS (IDSS)
 June 27, 2017
 Workshop on LWR Heat Storage

1

Outline

- Theory and Practice of competitive wholesale electricity prices.
- Recent drivers of falling electricity prices.
- Future drivers of volatile electricity prices.
- Valuing new storage technologies.

2

Energy Market Pricing & Volatility

- **Input #1: the supply stack.**
 - Incorporating outages.
 - Incorporating intermittent generation from renewables.
 - Incorporating volatile fuel prices.
- **Input #2: the load duration curve.**
 - Reflecting daily, weekly and seasonal load fluctuations.
 - Incorporating volatility, such as heat waves.
- **Output: the price duration curve.**

3

South Australia price distribution regime shift

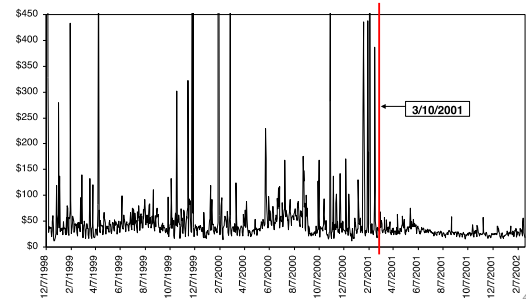

4

Energy Market – Historical Context

- **Short-run price is driven by short-run fluctuations in load, intermittent generation and available dispatchable capacity.**
 - Until recently, load had played the primary role, with occasional generator outages as well.
- **Growing role of renewables is only beginning to drive volatility, too.**
 - Negative prices are remarkable, but also a bit of a red herring.
 - Key is how they drive price down even in average load hours.

5

Capacity Adequacy and Grid Stability

- **Simple principal of electricity systems: generation must match load at all times.**
- **Different time scales produced different problems and solutions.**
 - At long time scales, we need to invest in sufficient capacity to meet future anticipated load. Capacity adequacy, including a margin.
 - scale of several years for new construction
 - scale of a year or two for major refurbishments
 - scale of months and weeks for maintenance
 - At short time scale ... of a day ... we need to have available sufficient capacity to meet volatile load, and, more importantly, to respond to contingencies such as unit or transmission outages. Operating reserves, whether spinning or non-spinning.
 - At shorter time scales of seconds and minutes, we need frequency control, etc., and reactive power. Grid stability.
- **Don't confuse or confound capacity adequacy with grid stability.**

6

Ancillary Services Markets

- **Vital, but in the grand scheme of things, not a large cost share.**
- **Intermittent renewables impose some new demands, but these have been and are manageable.**
 - Provision of “grid stability” is a valuable service, but it will never solve a significant crisis in the energy price

7

Capacity Markets (1)

- **Capacity markets are a type of insurance:**
 - w/o capacity markets, w/ energy only, a small number of hours with very, very high prices provide the large majority of total revenues to certain types of generators.
 - in a simple illustration produced by Joskow (2008), the 20 hours a year (< 1%) with a theoretically permitted wholesale price of \$4,000/MWh provides 33% of the net revenues earned by a baseload plant, 50% by an intermediate plant, and 100% by a peaker.
 - w/ a capacity market, the same revenue is provided as a capacity payment, and the wholesale price does not spike to \$4,000/MWh.
 - ≈ \$9/MWh in all hours, i.e., ≈ \$80/kW-year

8

Capacity Markets (2)

- **An accident of history that competitive markets were introduced at a time when there was plentiful generation capacity – both here in the U.S., and also in Europe.**
 - The marginal value of capacity was therefore zero.
 - Energy-only markets worked well enough.
 - It has long been clear that energy prices alone have not been sufficient to incent new capacity.
- **Times have changed, and capacity markets have been gradually introduced and are evolving.**
 - Capacity investments have been incented.
 - Many implementation problems exist.
 - Purchasing capacity is purchasing insurance. Determining the right amount of insurance is ALWAYS a difficult problem.

9

RECENT DRIVERS

10

MIT CEEP

MIT Center for Energy and Environmental Policy Research

Working Paper Series

Early Nuclear Retirements in Deregulated U.S. Markets: Causes, Implications and Policy Options

GEOFFREY HARATYK

Methodology

- **Analyze the determinants of price in two regions at two snapshots in time**
 - Mid-Atlantic (PJM) and Midwest (MISO north)
 - 2008 & 2015.
- **Dispatch model.**
 - Inputs:
 - Supply stack history
 - Load history
 - Output
 - Price history

12

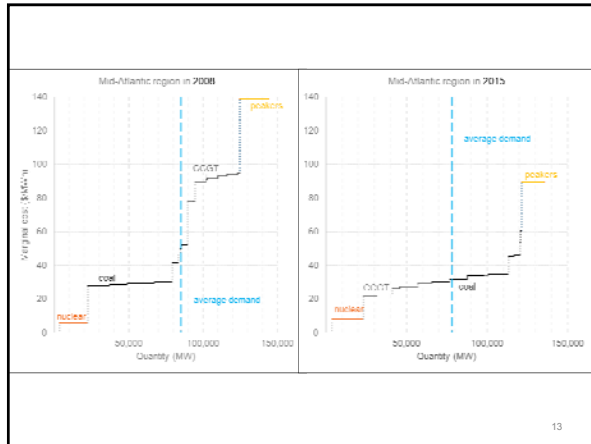

13

The drop in the price of natural gas was a primary driver of the drop in the electricity price.

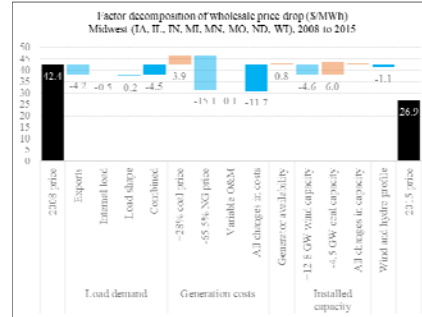

14

Some other results

- About ~20% of the U.S. nuclear capacity is retiring or at risk of retiring in the next 3 years.
- Fleet-average revenue shortfall = \$5.5-7.5/ MWh
- A moderate carbon price, say \$10/ MT CO₂, would be enough to bridge this revenue gap.

15

FUTURE DRIVERS

16

ZERO-VARIABLE COST POWER SYSTEMS

Implications for Electricity Market Design and Capacity Investments

IAEE Bergen - June 20, 2016
 Jesse D Jenkins
 Nestor Sepulveda
 Massachusetts Institute of Technology
 Fernando J de Sisternes
 Argonne National Laboratory

Methodology

- Theoretical model of energy market and capacity investment decisions in equilibrium
 - Least cost capacity investment and economic dispatch in a future planning year.
- Considers an extreme case of 100% zero variable cost (ZVC) generation (nuclear, wind, solar) plus energy storage, shiftable load, and price-responsive demand.
- Calculate the resulting equilibrium price distribution

18

Initial Supply & Demand

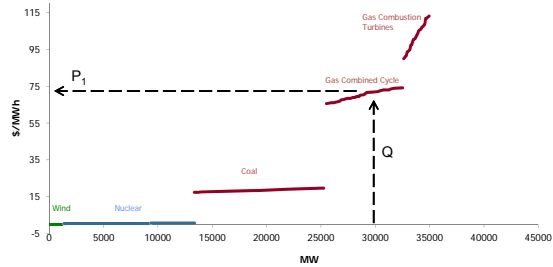

19

Increased ZVC Penetration

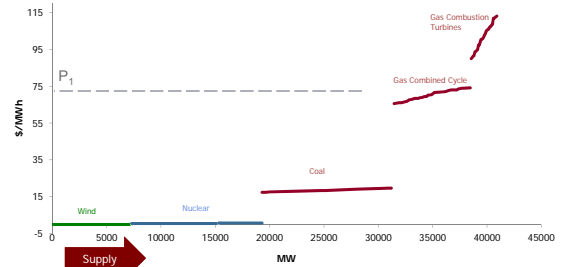

20

New Equilibrium

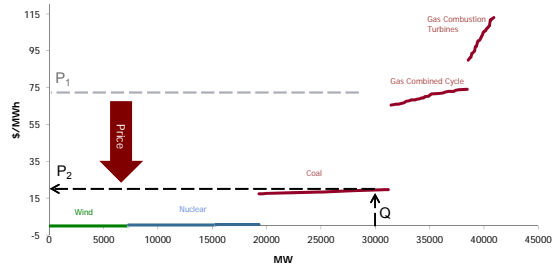

21

ZVCs drive prices to zero in most hours

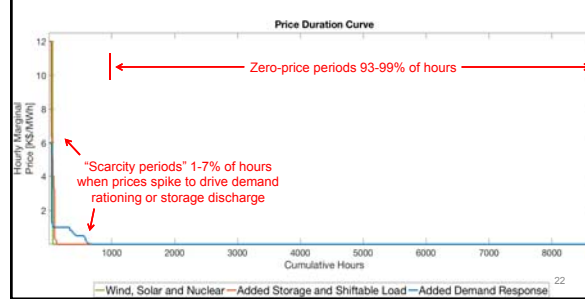

22

Spikes during rare 'scarcity periods' when generators earn all

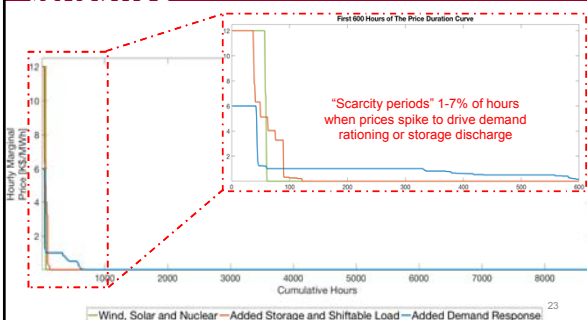

23

Yearly variation in demand and renewables drive revenue

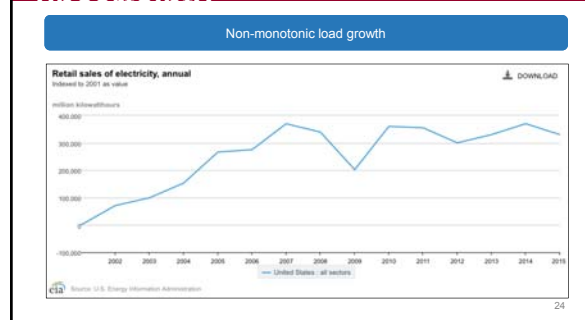

24

Yearly variation in demand and renewables drive revenue

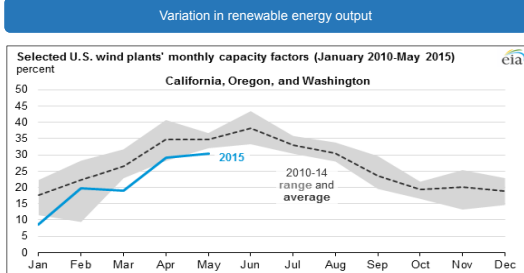

25

Implications for “energy-only” markets

1. No price caps: efficient demand rationing and scarcity rents are central to efficient energy-only markets
2. Regulators must make credible promises, allow scarcity events to unfold, and mitigate concern about regulatory hold-up
3. If investors or consumers (or regulators) are risk averse, need liquid markets for bilateral long-term contracts to align relative risk preferences
4. Mitigating market power is challenging, must be structural (rather than via market rules, as you can't impose price caps or other typical measures)

26

Implications for capacity markets

1. Capacity markets should establish long-term contracts that align relative risk preferences of investors and consumers
2. Length of capacity contracts should reflect relative risk preferences and involves trade-off between risk aversion (argues for longer contracts) and speed of market adaptation (argues for shorter contracts)
3. Penalties for non-performance should be established to incentivize availability during scarcity periods
4. Consumers must be exposed to marginal incentives during scarcity periods for efficient demand rationing
5. Strike prices for generators can be set to minimize incentives for supply withholding, mitigating market power

27

VALUING NEW STORAGE TECHNOLOGIES

28

Economics

- **Be cautious about using historical distributions.**
 - Reflect old technology portfolios, not new ones.
 - Reflect short-run out-of-equilibrium prices.
- **Price distribution and therefore value is determined within a system defined by a set of technologies.**
 - Economics focuses attention on the equilibrium outcome.
 - These are extremely difficult to determine with any reliability.
- **Practical benchmarks focus on a product and evaluate the cost of supplying that product.**
 - LCOE conditional on a capacity factor.

29

Growing solar capacity drives down the price in the hours when the sun shines

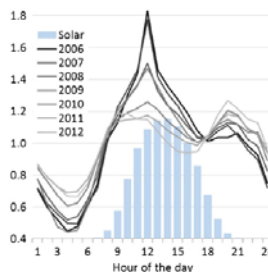
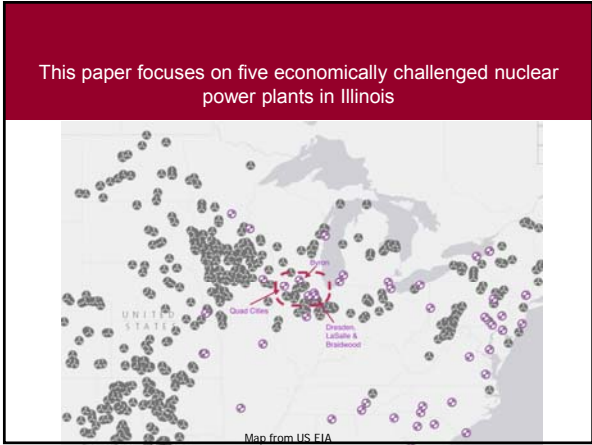
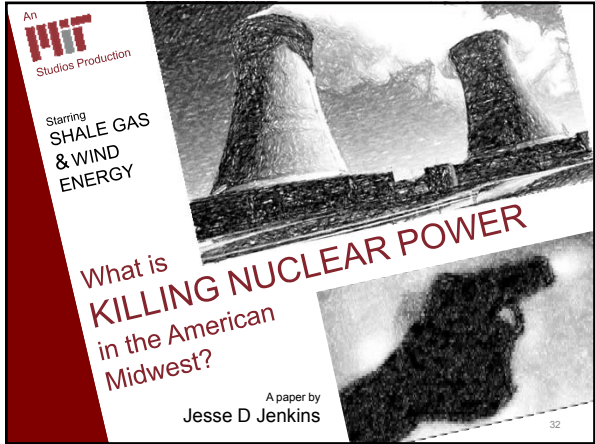

Fig. 7. The daily price structure in Germany during summers from 2006 to 2012. The bars display the distribution of solar generation over the day.

30

THANK YOU

31



Methodology:
Estimation with OLS with time fixed effects

$$\ln(P_d) = \beta \ln(D_d) + \gamma W_d + \delta N_d + \sum_{k=1}^{470} \alpha_{week,k} dw_k + \sum_{n=1}^7 \alpha_{day-of-week,n} dd_n + \sum_{i=1}^3 \eta_i z_i + \epsilon_d$$

demand wind gas week fixed effects
day-of-week fixed effects ISO expansion dummies

• Data from PJM and MISO. Complete time series for January 1, 2008 to December 31, 2016 (3,288 daily average observations).

34

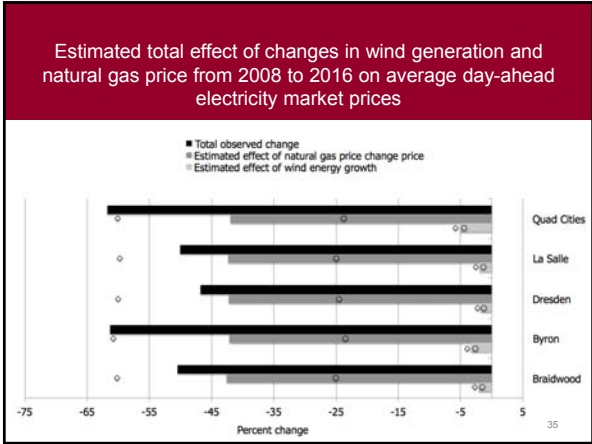

- Conclusions
- \$6.33 per MMBtu decline in average natural gas prices from 2008 to 2016 = 42-43 percent decline in average day-ahead prices (95% conf. interval: -23-61 percent).
 - -\$20 per MWh average price impact
 - 5x increase in daily average wind generation in MISO & PJM = 2-5 percent decline in average day-ahead prices (depending on the plant). (95% conf. interval range across all plants: -1.3-5.8 percent).
 - -\$1-2.5 per MWh average price impact
- 36

Westinghouse Non-Proprietary Class 3 © 2017 Westinghouse Electric Company LLC. All Rights Reserved.

Nuclear Plant BOP Technical Constraints

Joe Wooten
Principal Engineer, Systems and Equipment Engineering II



1

Westinghouse Non-Proprietary Class 3 © 2017 Westinghouse Electric Company LLC. All Rights Reserved.

Introduction

- Joe Wooten
- 37 years in Nuclear plants
- Mostly doing work in BOP with initial startup testing, thermal performance and pump testing and issues, and lately, AP1000 design/procurement issues.



2

Westinghouse Non-Proprietary Class 3 © 2017 Westinghouse Electric Company LLC. All Rights Reserved.

Turndown for current Nuclear Power Plants

- Many nuclear plants are either implementing load following strategies or are planning to.
- AP1000 Toshiba TC6F - 5% per minute (from 15% to 100% power) on increase, no limit on decrease
- GE ABWR - 15% per minute on increase, no limit on decrease



3

Westinghouse Non-Proprietary Class 3 © 2017 Westinghouse Electric Company LLC. All Rights Reserved.

Turndown for current Nuclear Power Plants

- Most nuclear plants BOP are designed for operation at or near 100% power.
- FW Heater and Heater Drain tank level controls are the biggest pinch point, especially if the old analog pneumatic controls are still in operation.
- PLC controllers can be re-tuned more easily.
- Most current nuclear plants have multiple feedwater, condensate, and heater drains pumps.



4

Westinghouse Non-Proprietary Class 3 © 2017 Westinghouse Electric Company LLC. All Rights Reserved.

Operating Experience

Comanche Peak Unit 2, February 14, 1996



5

Westinghouse Non-Proprietary Class 3 © 2017 Westinghouse Electric Company LLC. All Rights Reserved.

- It pays to be cautious when valving out the LP feedwater strings to increase MWe production using the stored heat in the energy storage system to replace the feedwater heating.
- The following plant incident demonstrates why this caution is warranted.



6

Comanche Peak Unit 2 experienced two secondary system transients which resulted in overpower turbine runbacks when reactor power reached 109%. Following the second runback, actual reactor power remained near 104% for 30 minutes.

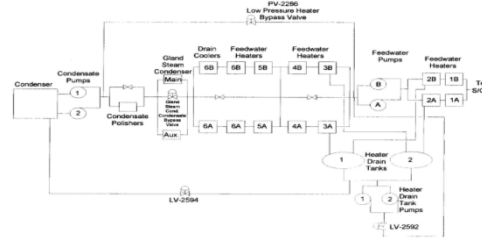

Figure 1
Simplified Condensate and Feedwater System
IS 1292
SER 10-96



- Per procedure, operators shut the extraction steam isolation valves to HP FW heaters 1A and 2A to balance extraction steam flows to the heater drain tanks.
- Virtually all feedwater heating was bypassed or isolated, and feedwater temperature dropped from 440°F to 210°F.



- The second overpower was caused by uneven differential pressures between the two heater drain tanks as Operations tried to restore full power.
- Once again, the loss of low-pressure feedwater heating caused extraction steam to isolate to the high-pressure feedwater heaters, and feedwater heating was lost for the second time.



Considerations for Retrofitting Current Nuclear Plants



- Retrofitting this type of energy storage scheme to existing plants will require a carefully thought out (and tested!) control program to slowly introduce the stored heat in place of the LP FW heaters.
- The simpler the heater drains system, the easier this transition will be. More complex systems with several drain tanks and pumps moving fluid forward in the cycle will be require more caution.
- MSR drains usually are drained to the high pressure heaters.



- Many of the FW heaters located in the condenser neck cannot isolate the extractions, so it might pay to use this heat that would be otherwise wasted if these heaters are bypassed.
- Heater Drains systems that are pumped forward may have to go on one pump or be routed to the condenser.
- Moisture removal stages may need bypasses to route the very wet steam mixtures to a heater drains tank or the condenser.
- Does the generator have the margin to produce extra power? A rewind may be necessary for plants that have uprated already.



13

- Heater drains pumps may have oscillation (shuttling) problems at lower drains flows.
- Replace old analog level control equipment with PLC.



14

Discussion

Questions?



15

Fort Calhoun-Cargill Proposed Steam Sales and Lessons Learned

Joe Gasper

2

Omaha Public Power District



3

Cargill Corn Milling Operation



4

OPPD Overview

- Began in 1946
- Serves Nebraska 13 counties.
- 12th-largest publicly owned electric system in number of customers served
- Generating Capability.....2,548.8 MW
- System Peak Load.....2,197.4 MW
- Operating revenue.....\$750,253,000
- Number of employees.....2,320
- Public entity governed by an elected board (Sole regulatory body)

5

Cargill Overview

- Began in 1865
- International Provider
 - Food
 - Agricultural
 - Risk Management
- More than 160,000 Employees
- Located in 67 Countries
- Over \$120 Billion in Revenues
- **Privately Owned Company**



6

Corn Milling – Products and Markets

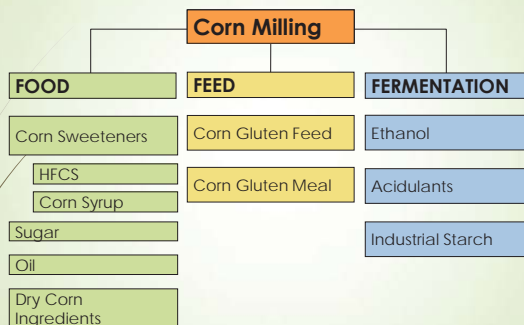

7

Genesis of Project (fall 2004)

- Cargill, Inc. uses natural gas for their process steam production at the Cargill food products site north of Fort Calhoun Station (FCS)
- Cargill plans further expansion of their facilities
- Cargill requested OPPD to provide process steam
- Cargill process steam requirement is 800,000 lb./hr (with possible increase in future), which is ~15% of FCS thermal production

1/10/05

8

U.S. Price of Natural Gas Sold to Commercial Consumers (Dollars per Thousand Cubic Feet)



9



10

Potential Steam Sales

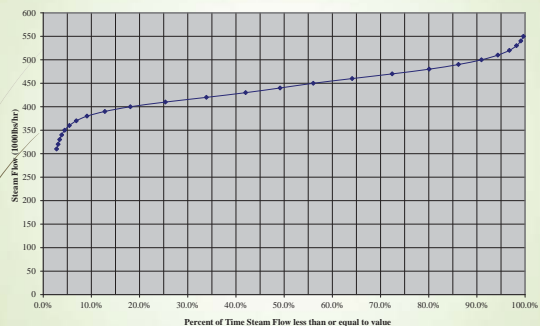

11

Ft. Calhoun EPU (2004)

- EPU to 1755 MWt planned (17% increase in thermal production)
- Fort Calhoun 2005-2006 Refurbishment Project Equipment Designed for Operation at 1755 MWt
 - Steam Generator Replacement
 - Pressurizer Replacement
 - Condenser Replacement

12

Project Scope per MOU

- Process Steam Supply Initial Design
- Licensing
- Insurance
- Land rights
 - Land owned by either OPPD or Cargill
- Contract
 - OPPD to develop rate structure
 - Steam previously supplied to meat packing in 1950s
 - No change in State of Nebraska law enabling public power required to supply steam to Cargill

13

Process Steam Supply Initial Design

- Process steam would be produced by a reboiler island adjacent to the FCS turbine building
- 600 psig superheated tertiary steam would be transported ~7500 feet via a pipeline to the Cargill site
- Heated tertiary makeup water would be transported from Cargill to FCS via a return pipe to a reboiler feed storage tank
- The reboiler heat exchanger tubing would be the pressure boundary between FCS secondary side (main) steam and the tertiary process steam supply loop to Cargill

14

Simplified P&ID for FCS Cogeneration Cycle

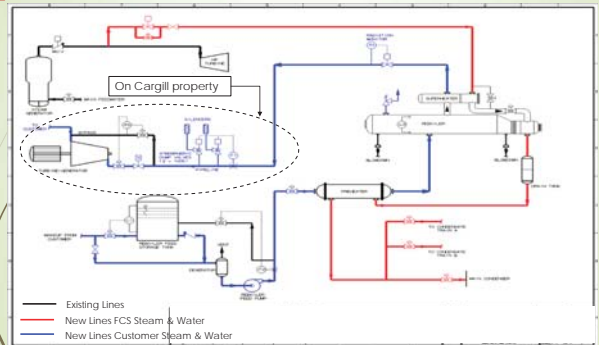

15

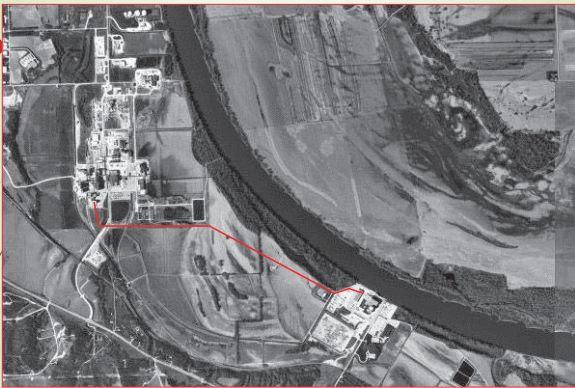

16

Licensing

- OPPD met with NRC on January 10, 2005
- Meeting summary
 - The proposed steam supply to Cargill was technically feasible, with no significant licensing, security, or safety issues found
 - Adequate safety margins would be maintained with or without an associated EPU

17

Insurance

- OPPD nuclear insurance issue could not be overcome
 - Steam primarily used in fermentation
 - Some steam used by Cargill in making corn sweeteners
 - Corn sweeteners sold to soft drink industry
 - Cargill could not sufficiently isolate food process lines
 - Possibility that tritium could migrate to corn sweeteners and ultimately end up in soft drinks
- **Inability to resolve this issue terminated the project on July 2005**

18

Use of heat storage technology

(Had it been available)

- Would have greatly simplified the design
- Heat storage would have most likely been on Cargill property
 - Most likely had heat exchanger in protected area to minimize radiological release points
 - Not clear this would have overcome tritium issue

Follow on Actions through 2011

- Cargill installed (and subsequently removed) electrical boilers
- OPPD
 - Upgraded switch yard at Cargill
 - Pursued EPU until 2011

U.S. Price of Natural Gas Sold to Commercial Consumers (Dollars per Thousand Cubic Feet)



Current Status

- Cargill continues to use natural gas
- OPPD closed Ft. Calhoun and replaced power with wind and natural gas



Footnote on Gösgen Nuclear Power Plant (Switzerland)

- In addition to electricity, the Gösgen nuclear power plant has been supplying process heat to the adjacent cardboard factory Niedergösgen since 1979. Approximately 150 gigawatt-hours of process steam are extracted annually from the nuclear power plant.

http://de.nucleopedia.org/wiki/Kernkraftwerk_Gösgen



ENERGY STORAGE

A Near Term Solution to Nuclear Woes?

Steve Brick
 Senior Advisor, Clean Air Task Force
 Presented to the MIT Workshop on
 Light Water Reactor Heat Storage for Peak Power and Increased Revenue: Focused Workshop on Near-Term Options
 27 June 2017

PJM WHOLESALE PRICES - 2016

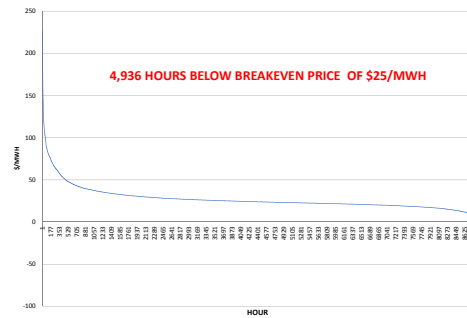

Key questions

- Can storage plus unused/undervalued output from LWRs be used to boost revenues?
 - Emphasis on near-term rather than mid- or long-term
- Is the technology cost-effective?
- Is there a commercially viable model that will work for the customer and the utility?

Can storage help solve this problem?

Why are we having this discussion?

- Brutal wholesale market prices
 - Persistently low gas prices
 - Over-capacity
- PJM Market as an example
 - Much of the nation's existing LWR capacity is in PJM or similar markets

PJM- 2016 AVERAGE HOURLY WHOLESALE PRICE

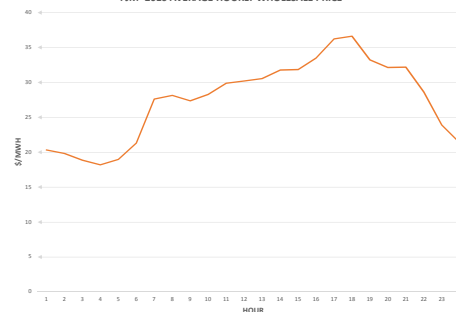

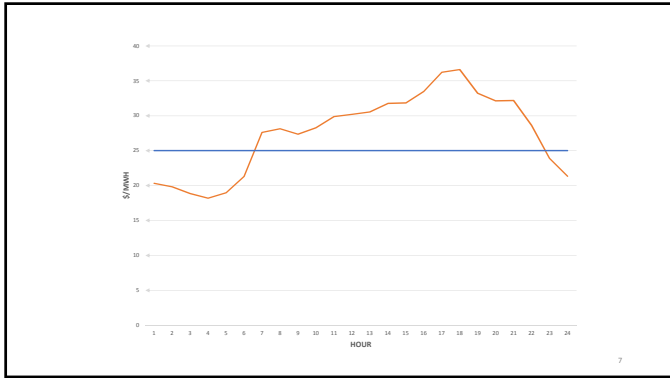

7

Value calculus

Cost of storage + input energy (corrected for conversion loss)

MUST BE

< the cost of the competition

10

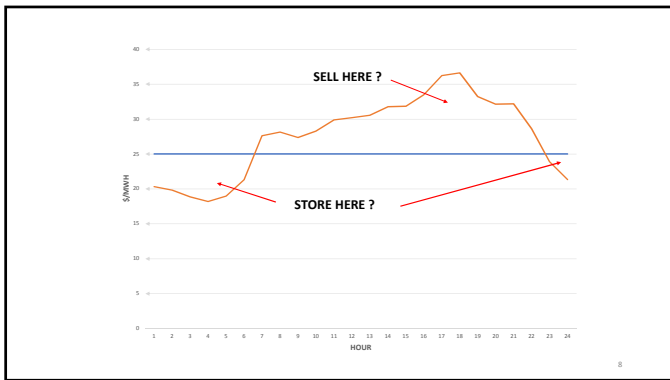

8

Most of the discussion about storage

- Focuses on batteries as a means of managing surplus electricity from intermittent resources such as wind and solar
- Two problems
 - Batteries are expensive
 - Surplus from wind and solar is too variable to achieve high utilization rates for storage

11

Storage solutions must offer service that will be

- Predictable
- Reliable
- Cost-competitive with the prevailing alternative
 - Electricity
 - 2016 average PJM wholesale price = \$26/MWH
 - New gas build = \$37/MWH
 - Fuel
 - Natural gas price ≈ \$3/MMBtu

9

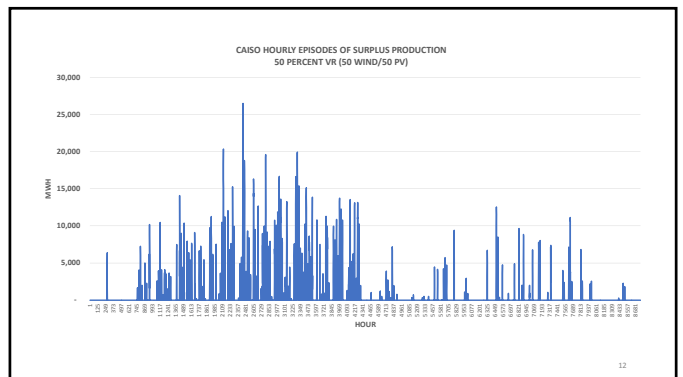

12

Cumulative surplus is very difficult to manage

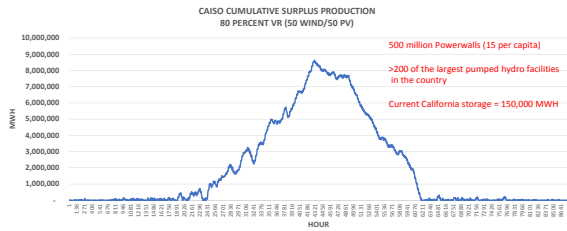

13

STORAGE COSTS (¢/kWh) AS A FUNCTION OF UTILIZATION RATE
OPTIMISTIC BATTERY COSTS (\$100/kWh)

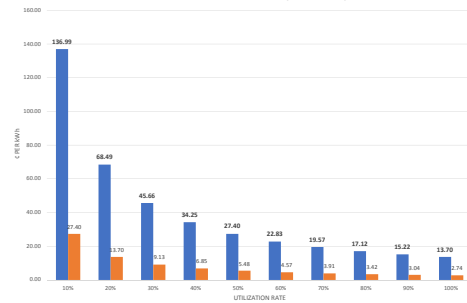

16

Commercial viability matters

- Even if storage could be built to manage massive seasonal surplus, its commercial viability would be doubtful
- A system built to manage an 8 million MWh cumulative surplus would operate at an annual utilization rate of around 1%
- The cost of stored energy would be more than \$1,000/MWh

14

What about thermal storage?

17

STORAGE COSTS (¢/kWh) AS A FUNCTION OF UTILIZATION RATE
CURRENT BATTERY COSTS (\$500/kWh)

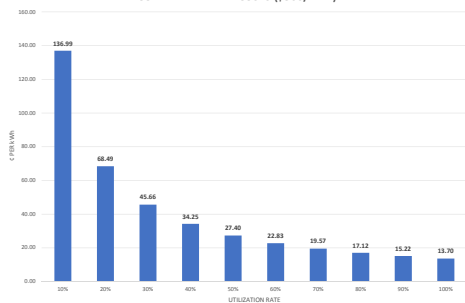

15

THERMAL STORAGE AT \$10/kWh
COMPARED TO OPTIMISTIC BATTERY COSTS

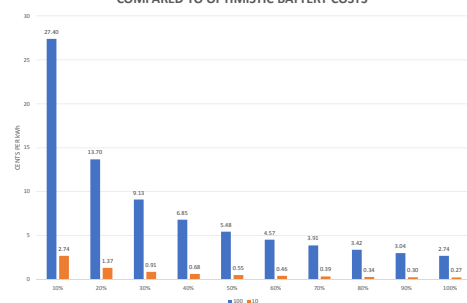

18

Thermal storage at \$10

- Beats batteries by a substantial margin
- At high utilization rate adds a modest cost
- Daily differential between low cost off-peak hours and higher cost on-peak hours is a persistent feature of markets
- How does the calculus work out?

19

LWR Electricity to thermal storage—industrial heat substitute?

- Power cost = \$25/MWH
- Storage cost = \$2.76/MWH
- Net cost = \$27.76/MWH
- Average value = \$36.86/MWH
- \$8.14/MMBtu equivalent
- At current gas costs of around \$3/MMBtu, this doesn't appear to be competitive

22

LWR Electricity to thermal storage—off-peak on peak daily arbitrage

- Power cost = \$25/MWH
- Storage cost = \$3/MWH
- Net cost = \$28/MWH
- Average value = \$37/MWH
- Is \$9/MWH differential enough to support investment in additional technology to convert stored heat back into electricity?

20

LWR heat to thermal storage—industrial heat substitute?

- Go directly from LWR heat to storage, avoid the losses involved in generating electricity
- \$2.26/MMBtu equivalent (assuming 33 percent efficiency)
- At current gas costs of around \$3/MMBtu, this is potentially competitive
- Questions
 - Interconnection with industrial energy users?
 - How much cheaper than prevailing alternative does it need to be to successfully displace incumbent?

23

LWR electricity for high value arbitrage?

- Top 1000 hours in PJM have average value of \$58/MWH
 - Power cost = \$25/MWH
 - Storage cost = \$27/MWH (10 percent utilization rate)
 - Net cost = \$52/MWH
- Higher value hours occur sporadically, and timing the arbitrage play is very difficult

21

Preliminary conclusions

- Thermal storage appears to be much cheaper than batteries
- Current market conditions (low gas and power prices) suggest that it is not a near term solution for existing LWRs
 - California is a "better" market, but nuclear is on its way out there
 - If other RTOs continue to increase wind and solar, conditions might improve for LWR plus storage
- Straight heat to industrial users a better bet?

24

Firebrick Resistance Heated Energy Storage (FIRES): The Other Thermal Storage Option

Electricity to High-Temperature Heat

Charles Forsberg

Department of Nuclear Science and Engineering; Massachusetts Institute of Technology
77 Massachusetts Ave; Bld. 24-207a; Cambridge, MA 02139; Tel: (617) 324-4010;
Email: cforsber@mit.edu; <http://web.mit.edu/nse/people/research/forsberg.html>

Light Water Reactor Heat Storage for Peak Power and Increased Revenue

Salon T, Samberg Conference Center, Building E52 7th floor, MIT Campus
Cambridge, Massachusetts; June 27-28, 2017



1

2

A Low-Carbon World Changes Electricity Markets



2

No Change In Energy Policy for 300,000 Years, Throw a Little Carbon on the Fire



Cooking Fire



Natural-Gas Combined Cycle

Low Capital-Cost Power Systems: Economic at Part Load

Nuclear, Wind, and Solar Are High-Capital-Cost Low-Operating-Cost Technologies



Must Operate Near Full Capacity for Economic Energy



4

Nuclear Energy Did Not Change Fossil Fuel Energy Policy or the Market

New England Electricity Demand Over One Year

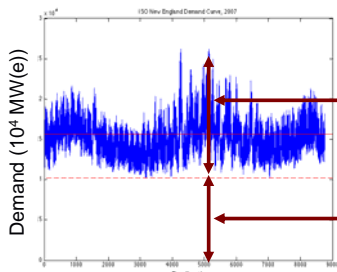

Time (hours since beginning of year)

- Low-capital-cost High-operating-cost fossil plants for variable energy production
- High-capital-cost Low-operating-cost nuclear plants for base-load

5

If No Fossil Fuels Because of Concerns About Climate Change, What Is the Replacement For Variable Electricity Production?

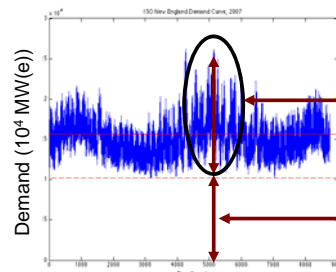

Time (hours since beginning of year)

- Variable Electricity Market
- Base-load Electricity Market

6

If Add Wind or Solar, Base-Load Electricity Demand May Disappear: The California Duck Curve

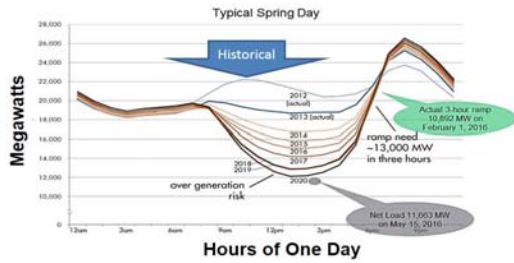

Solar Eliminates Mid-Day Demand For Other Electricity Sources But Need More Variable Power⁷

Impact of Large Solar on Electricity Prices California Sunday—Real Data

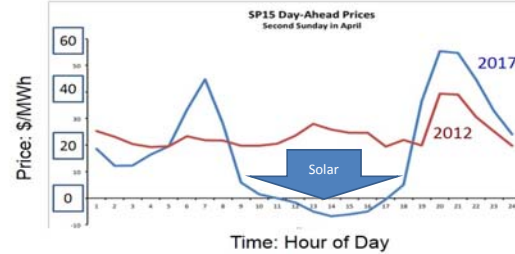

Price Collapse for Solar at 15%, Wind at 30%, and Nuclear at 70% of Total Electricity Production⁸

Option A: LWR Heat Storage Solution to Duck Curve
This Workshop: Move Low-Price Energy to When Higher Prices



Option B: FIRES (Electric) Solution to Duck Curve
Bottom Dweller: Move Low-Price Electricity to Industrial Heat Market

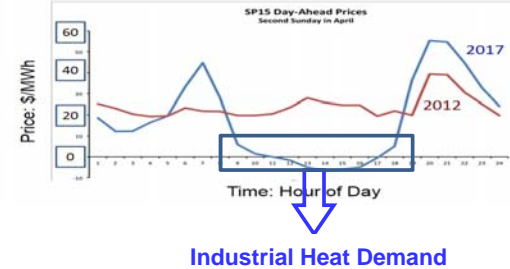

FIRES sets minimum electricity price near natural gas; thus, helps nuclear, wind and solar while reducing energy costs for industry

Firebrick Resistance-Heated Energy Storage (FIRES)

Goal: Start Deployment by 2020

Firebrick Resistance-Heated Energy Storage (FIRES)

- Buy electricity when electricity prices are less than fossil fuels used by industry (natural gas)
- Electrically heat insulated mass of firebrick to very high temperatures
- Use stored heat delivered as hot air for two applications
 - Industrial heat
 - Peak electricity production



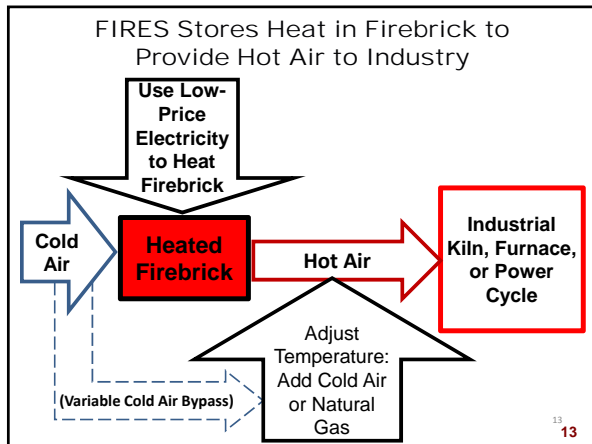

Price Collapse Real: Western Iowa with Wind
Half the Time Electricity is less than Natural Gas

- FIRES Electric Heaters Operate in Two Modes
 - Electricity to hot air for immediately use by furnace
 - Electricity to heat used immediately and heat firebrick to provide heat at a later time
- In Iowa FIRES may provide heat to industrial furnace for 6000 hours per year
 - 4000 hours direct heating
 - 2000 hours heat from storage

14

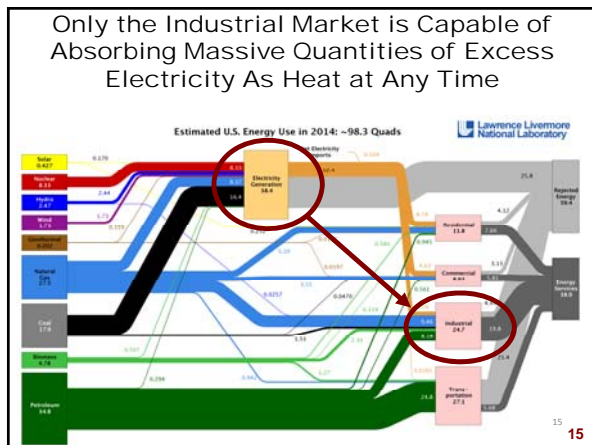

Recent China Experience: Heat Storage Units for Large Apartment Complexes

- Eight-hour night discount rate for electricity
- Units up to 8 MWh storage capacity
- Hot air from firebrick heats hot water to 85°C for building heat and use
- Hot air circulated between FIRES and water heat exchanger
- Factory fabricated

16

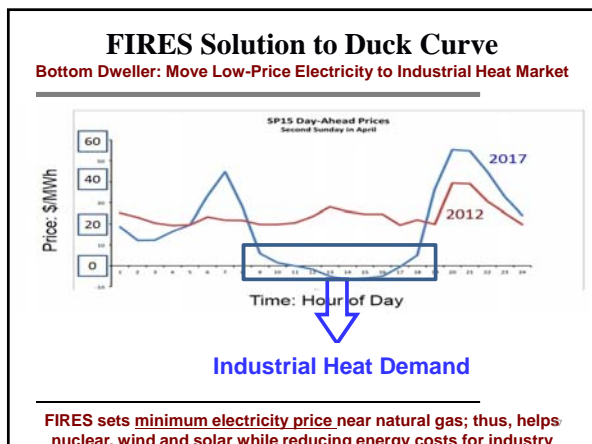

FIRES Status

- Capital cost estimates: \$5-10/kWh
- Market created in the last 2-3 years with significant addition of wind and solar (Could have built in 1920)
- Near-term goals (Exelon and Industrial Partners)
 - Develop and deploy FIRES for industrial market (Integrate with gas burners; beyond producing 85 C hot-water)
 - Access to wholesale electricity markets by FIRES storage systems or behind the meter
 - Same rules as for other storage technologies
- Next Step: Higher temperature FIRES to lower-cost and expand market to more industrial customers

18

Coupling FIRES to Gas Turbines

Conventional Gas Turbines
Nuclear Air-Brayton Combined Cycle (NACC)

2025-2035

Combined Cycle Gas Turbine with FIRES

- FIRES converts low-price electricity into stored heat to reduce “expensive” natural gas consumption
- Major change—FIRES in pressure vessel to match gas turbine pressures

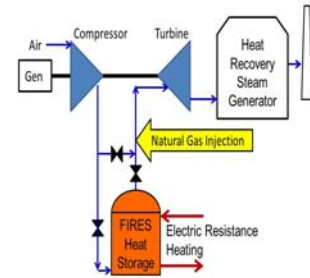

High Temperature Reactor with Nuclear Air-Brayton Combined Cycle (NACC)

Stored FIRES Heat, Natural Gas or Hydrogen

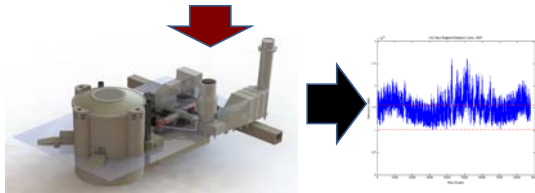

Base-Load Reactor Gas Turbine Variable Electricity And Steam

Require Heat Delivery to Power Cycle Between 600 and 700°C

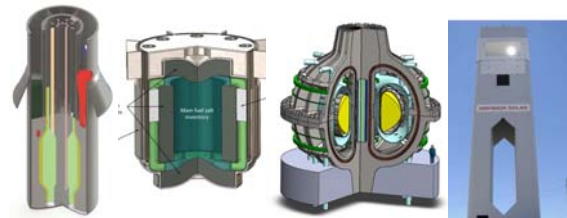

FHR (Solid Fuel and Clean Salt) Molten Salt Reactor (MSR) Salt-Cooled Fusion Solar Thermal Solugas
Terrapower Design

Heat Above Compressed Gas Temperature

Nuclear Air-Brayton Combine Cycle (NACC) Base-load Reactor Heat Input and FIRES Heat Input

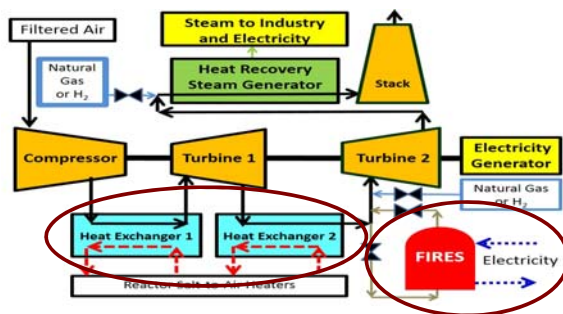

NACC: Only Way To Beat Cheap Natural Gas is to Burn it More Efficiently than Stand-Along NG Plant

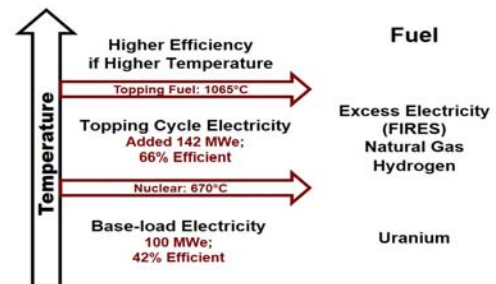

Stand-Along Combined-Cycle Natural Gas: 60% Efficient

The Way to Compete With Cheap Natural Gas Is Burn Less Natural Gas per KWh for Peak Power

- Peaking efficiency greater than stand-alone natural gas plant
- NACC: incremental heat to electricity 66+% efficiency
- Stand-alone combined cycle: 60% efficiency

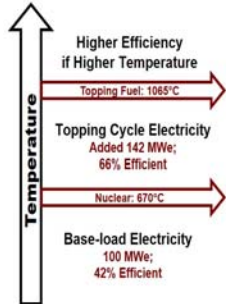

Session II
The Technology Options and Status

A Case Study for Load Following with Heat Storage at an Existing LWR

PWR Discussion



Presented to:
MIT Workshop on Light Water Reactor Heat Storage

Presented by:
Robert D. Varin, Jr., PhD
Dominion Engineering, Inc.

June 27-28, 2017

19100 Sunrise Valley Dr. #220
Reston, VA 20191
703.637.7300
www.domeng.com

Overview

- Background and perspective
- Challenges of redesigning existing plant for load following
- Preliminary study of load following with constant primary plant operations
- Options for extraction of steam/heat storage
- Technical issues

2

MIT Conference



Background and Perspective

- Nuclear as dispatchable source of electricity
 - Conventional load following as in EU may not be economical in other countries
 - Challenging to propose a major redesign of an existing plant or licensed design to replicate capabilities of EU plants
- Primary plant cycling introduces challenges in ageing fleet
 - Technical issues (reactivity control, chemistry control, demand on SSCs)
 - Aging of large equipment
 - Significant effort to relicense primary plant
 - Operational risk (training, I&C, etc.)
- Secondary plant cycling may be more straightforward
- Coupled with heat storage – 100% capacity factors may be achievable with constant primary plant operations

3

MIT Conference



Technical Challenge

Load Following at an Existing LWR

- Primary Plant
 - Moderator concentration
 - Doppler effects
 - Core power distribution
 - Core design
 - Poisoning
 - Non-optimal burnup
- Secondary Cycle
 - Demands on turbine
 - Flows and velocities in extraction and drain lines
 - Turbine efficiency
 - Feedwater pump turbine (FWPT) operation at reduced steam flow or T,P

4

MIT Conference



Load Following in EU

- Operation between 50 to 100% at 3-5% P_r per minute
 - Typically achieved through control rod manipulations or boron concentration (CVCS system in PWR)
 - Plants designed with significant maneuvering capability

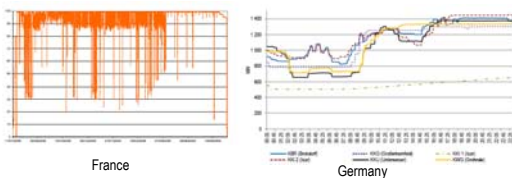

5

MIT Conference



Assumptions

- It is desirable to run the primary plant at constant output
 - No fundamental design changes
 - No chemistry maneuvers
 - No retrofitting a means of reactivity control (e.g., gray rods)
- Small load following (e.g., a few percent or 50 to 100 MWt) not likely to be economically viable
- Larger turndown probably required (~20% of thermal output)
 - ~350 to 500 MWt steam export to heat storage media
 - Equivalent to about 500 to 700 tons steam per hour
- Turndown is required about 20% of the time
- Turndown of plant output by 20% *does not mean* secondary plant needs 20% uprate (see next slide)

6

MIT Conference



Concept and Strategy

- Keep primary plant as-designed
- Export steam to heat storage
- Allow for turbine hall load following (turndown) up to 20%
- Store the energy
- Return the energy – e.g., FW heating
 - When economical (highest revenue)
 - Over time at “lower pace of energy return”
- Include a capability for excess heat storage and return
 - Capacitor/battery concept
- Modify/adapt the steam plant (turbine hall) to accommodate small to moderate uprate
 - Similar to MUR uprate (~75 have been licensed in US)

7

MIT Conference



Past Experience

- Upgrading the secondary plant may be analogous to strategies already proven:
 - Measurement Uncertainty Recapture - MUR (typically 1.5%)
 - Stretch Power Uprate - SPU (5-7%)
 - Extended Power Uprate - EPU (>12%)
- MUR and SPU successfully implemented worldwide over the last 30-40 years at >75 plants
 - No “major” modifications to turbine hall
- This case study was based on 4% uprate of turbine hall
 - 15% may be achievable

8

MIT Conference



Existing Baseload Plant with Load Follow

- No Heat storage case (~95% capacity factor)

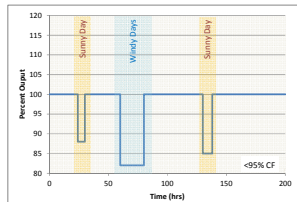

9

MIT Conference



Baseload Plant with Flexible Operations

- Primary plant 100% (with 100% capacity factor)
- Steam plant 80-104% (not 80-120%!)
- Achieved by gradually returning energy 80% of time

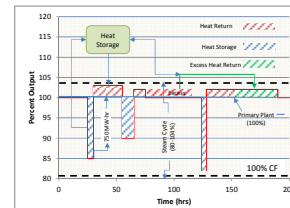

10

MIT Conference



Case Study

- Prototypic heat balance (no deaerator)
 - At this plant HP heater is FWH 1 (some plants differ in numbering)
 - Heat flows in MW_{th} shown (ΔMW between points is heat transfer/power)

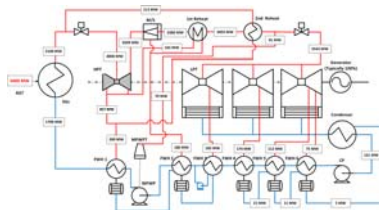

11

MIT Conference



Export and Return Options

- Direct extraction from HPT or LPT not likely to be viable
- Export locations (tertiary loop only shown for Option 3)
 - Option 1: High Pressure Main Steam (MS) (HPE)
 - Option 2: Low Pressure Reheated Steam (LPE)
 - Option 3: Low Pressure Reheated Steam in MSR with Tertiary Loop
- Tertiary loop
 - Steam to gas
 - Steam to salt
 - Other
- Return locations
 - Moisture separator reheater
 - FWH Train
 - Other



12

MIT Conference



Systems Potentially Affected

- Turbine generator (T/G) Set
- Main steam (MS)
- Extraction steam (ES)
- Condensate (CD)
- Feedwater (FW)
- Feedwater Pump Turbine (MFWPT)
- Heater drain (HD) system
- Moisture separator reheater (MSR)

13

MIT Conference

Definition Engineering, Inc.

Steam Extraction (w or w/o reboiler)

- Option 1 – Main Steam Extraction (MSE)
 - Saturated steam: 290°C (~550°F) – highest enthalpy
 - Smallest line sizes and greatest potential for generating highest temperature heat storage or steam (tertiary system)
 - Highest energy potential for heat storage
 - If tertiary product is sent over long distances, the higher pressure could significantly reduce pipeline diameter.
- Option 2 – Downstream of Moisture Separator Extraction (Low Pressure Steam Extraction – LPE)
 - 215 to 260°C (420 to 500°F)
 - 2-1. Between M/S and 1st stage bundles
 - 2-2. Between 1st stage and 2nd stage bundles
 - Some degree of superheat is desirable to minimize the potential for moisture in the pipeline and accommodate a smaller pipe size
 - *It is expected that Option 2 would provide broadest range of applications*

14

MIT Conference

Definition Engineering, Inc.

Reheater Modification

- Option 3 – Adding a reboiler bundle and return bundle to the reheater
 - Increases steam pressure drop across MSR - efficiency and generation penalty during normal operation
 - Requires additional analyses (e.g., tube rupture analysis, additional air removal capability)
 - Return temperature from heat storage needs to be very high to eventually return the heat to the nuclear steam cycle. However, it could result in higher degree of reheat and therefore, lower moisture content entering the first LPT stage increasing thermal efficiency of the plant.
 - MSR vendors would need to be consulted if such a solution is technically feasible since it has not been past industry practice. MSR may need to be completely redesigned, inspected and tested.

15

MIT Conference

Definition Engineering, Inc.

Export and Energy Return FW Heating Example

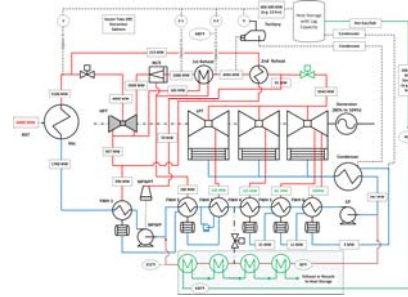

16

MIT Conference

Definition Engineering, Inc.

Effects on Turbine Hall

- Turbine Generator
 - Design issues
 - HPT throttle margin
 - Overspeed protection
 - Turbine Water Induction (TWI) analysis
 - Steam flow path
 - Moisture management
 - Blade optimization
 - Last stage blade
 - Low load analysis
 - Uninstalled flutter consideration
- Main Condenser
 - Generally not impacted
 - Higher drain flows
 - “Nuclear grade” condensate storage volume (some impact)

17

MIT Conference

Definition Engineering, Inc.

Effects on Turbine Hall (cont.)

- Main Feedwater Pump Turbine
 - Most impacted component
 - Design challenges
 - Lower inlet pressure
 - Wetter steam
 - Possible scenarios
 - Inlet bowl coefficient to be modified
 - MFWPT drive system redesign
- Moisture Separator
 - Moderately impacted component
 - Nozzles locations for the LPE
 - Steam shell side velocity
 - Steam tube side velocity
 - Tube vibration analysis

18

MIT Conference

Definition Engineering, Inc.

Considerations

- The preliminary case study identified the following other impacts
 - T/G modification and steam flow path optimization (achievable)
 - MFWP drive unit (i.e., steam turbine) - (additional study)
 - HD and MSR drain control valve sizing (achievable)
 - ES System (line and in-line component sizing) (achievable)
 - FWHs (various design considerations)
 - MSRs (affected by LPE cases only)
 - Lowers cross around pressure to LPT and MFWP turbines - minimize impact on the cycle by modifications to *increase* the cross-around pressure by ~15%
 - HPT (due to high pressure turbine shaft power demand)
- No unsurmountable hurdles at this time
- More refined studies may be warranted

19

MIT Conference



Concluding Remarks

- *Primary system safety margins are unchanged.*
- *Operation at constant thermal power could mean operation at essentially constant primary temperature - this reduces the burden of normal load following on system such as stress cycling and corrosion issues.*
- *No need to change reactivity control through chemistry changes or adding gray rods.*
- *Less demand on primary instrumentation.*
- *Potentially more straightforward path to license amendments that those required for true load following*

20

MIT Conference



The University of Texas at Austin
Mechanical Engineering

Idaho National Laboratory

Steam Accumulators for Thermal Energy Storage at Nuclear Power Plants

Neal Mann
Ph.D. Student, Department of Mechanical Engineering, The University of Texas at Austin
Intern, Idaho National Laboratory

MIT Heat Storage Workshop, 2017-06-27

Outline

- History and design of steam accumulators
- Commercial steam accumulator applications
- Steam accumulators in electric power applications
- Integrating steam accumulators with nuclear power plants
- Steam accumulator economics in power markets
- Conclusions

2

Energy Accumulators

“[The large dock area required to produce 100 horsepower], considering the vast costliness of artificial dock construction, is obviously prohibitory of every scheme for economizing tidal energy by means of artificial dock-basins...however convenient and non-wasteful the accumulator—whether Faure’s electric accumulator, or **other accumulators of energy hitherto invented, or to be invented**, which might be used to store up the energy yielded by the tide-mill during its short harvests about the times of high and low water, and to give it out when wanted at other times of six hours.”

—Sir W. Thomson (The Lord Kelvin), Nov. 1881

3

The Steam Accumulator

- Proposed by **Andrew Betts Brown**, ca. 1870
- Developed for rudder steering on steam ships
- Adapted to steam-powered cranes at ports



4

A. E. ODY.
STEAM POWER PLANT AND THE LIKE.
APPLICATOR FIELD AND TO OOD.
1,006,477. Patented Oct. 24, 1911.
PREFERRED EMBODIMENT

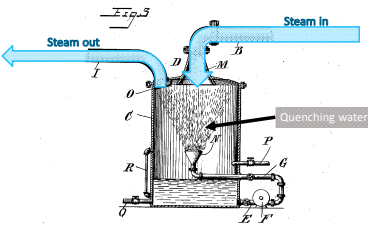

5

The Ruths Steam Accumulator

- Dr. Johannes Ruths (1879–1935), Swedish engineer
- Initial commercial designs: early 1900’s
- “Steam Plant,” U.S. Pat. 1,585,791 (1926)
- Awarded the John Price Wetherill Medal by The Franklin Institute (1929), among other honors

6

“Constant temperature, variable water level accumulator”

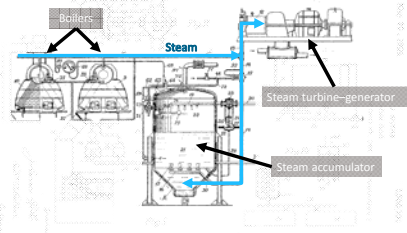

7

True or False:
A steam accumulator stores steam.

Answer:
True
(but most of the heat is **in the water!**)

8

Storage Volume for 1,000 t steam*

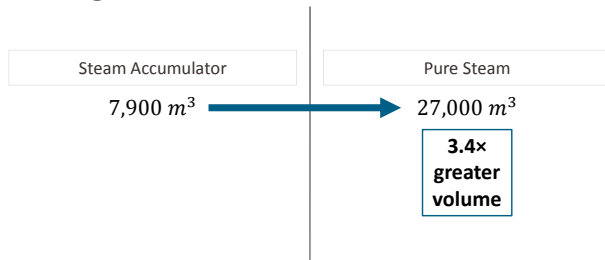

9

Why Steam Accumulators?

Pros

- Commercially available
- Large scale
- Mature technology
- Uses common materials (steel pipe, boilerplate)
- Large volume → low heat loss rate
- Water
 - doesn't degrade with cycling
 - is cheap
 - has high thermal conductivity ($\approx 0.5 \text{ W/m}\cdot\text{K}$)
 - has high heat capacity ($\approx 4.2 \text{ J/g}\cdot\text{K}$)
 - has high heat of vaporization ($\approx 2.3 \text{ kJ/g}$)

Cons

- Saturated steam only (without superheater)
- Safety risks of steam (high pressure)
- Expensive pressure vessels (most designs)
- Low energy density
 - $0.02 \text{ kWh/kg H}_2\text{O}$ ($68 \text{ kJ}_e/\text{kg}$)
 - $0.01 \text{ kWh/l H}_2\text{O}$ ($50 \text{ kJ}_e/\text{l}$)
 - Comparable to CAES, flywheels

10

Steam Accumulator Designs

- **Variable pressure (Ruths)**
 - Single tank, sliding pressure
- **Expansion**
 - Two tanks: one accumulator, one evaporator
 - Constant output pressure
- **Displacement**
 - Two tanks: one liquid water only (thermocline), one evaporator
 - Constant output pressure

11

Commercial and Industrial Applications

- Nearly anything that uses or generates steam
- Wood pulping
- Industrial batch processing
- Food processing
 - Sugar cane
- Healthcare
 - Pharmaceuticals
 - Sterilization
- Transportation
 - Steam catapults
 - Steam locomotives
- Combined heat and power/cogeneration

12

Steam Accumulator Engineering and Sales

- **Dillinger (Germany)**
 - Khi Solar One: 19 accumulators, 100 MWh energy capacity total ($\approx 130 \text{ kWh/m}^3$), 260 t pressure vessel steel each
- **SteamBoost (UK)**
 - Various projects worldwide since 1996, most in 100's m^3 ($\approx 1 \text{ MWh}$)
- **EnergyNEST (Norway)**
 - Steel pipes embedded in enhanced concrete cylinders; mineral oil or steam/water; steam storage codeveloped with Aalborg CSP
- Numerous small companies sell accumulators with capacities of 10's of tonnes of steam

13

Charlottenberg Power Station, Berlin

- Steam accumulators built 1929
- >600 t steam
- 50 MW_e (separate turbine)
- 67 MWh
- 16 tanks
- Tank dimensions: 65' h x 14' d (20 m x 4.3 m)



14

SAs in the Electric Power Industry

Name	Location	Online	Type	HTF	Outlet [°C/MPa]	Power [MW _e]	Energy Cap. [hours]	Sensible TES	Latent TES
PS10	Sevilla, Spain	2007	CSP Tower	Steam (DSG)	250/4.5	11	0.5	N/A	Steam acc.
PS20	Sevilla, Spain	2009	CSP Tower	Steam (DSG)	250/4.5	20	0.5	N/A	Steam acc.
DAHAN	Beijing, China	2012	CSP Tower	Steam (DSG)	400/4.5*	1	1	Mineral oil	Steam acc.
Khi Solar One	Uppington, South Africa	2016	CSP Tower	Steam (DSG)	530/4.5*	50	2	N/A	Steam acc.
eLLO	Llo, France	(2018)	CSP Linear Fresnel	Steam (DSG)	285/7.0	9	4	N/A	Steam acc.

15

Steam Accumulators and Nuclear Power

- **Basic design options**
 - Steam accumulator only (variable pressure, expansion, displacement)
 - Steam accumulator with steam reheat/superheat
- **Hybrid designs**
 - Steam accumulator surrounded by sensible storage material (e.g., concrete)
 - Steam accumulator with embedded/surrounded PCM (e.g., NaNO₂)
- **Steam turbine options**
 - Separate steam turbine for accumulator
 - Oversized main steam turbine for feedwater reheater design

16

Retrofits to Existing PWRs/PHWRs

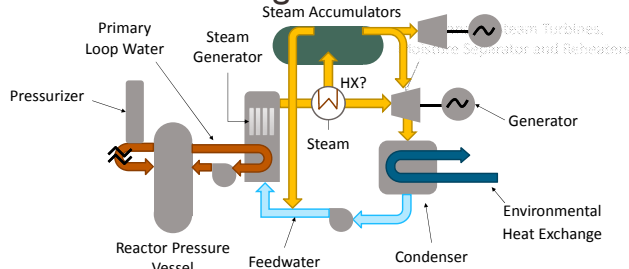

17

Retrofits to Existing BWRs

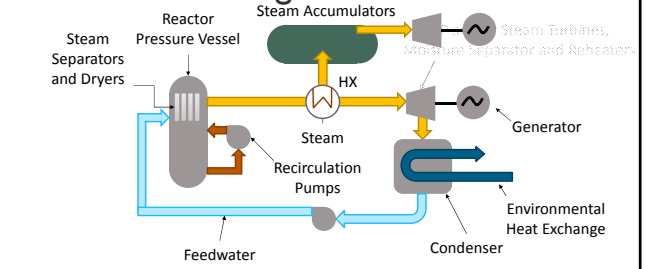

18

Other Opportunities for Steam Accumulators

- New plant designs with feedwater reheaters and oversized steam turbines
- Scalable for latest designs: Water-cooled SMR to 1,600 MW_e Gen III+
- Advanced reactors with steam Rankine power cycles (including Brayton–Rankine combined cycles)
- **Other thermal power plants with steam Rankine power cycles**
- Alternative pressure vessels: pre-stressed concrete, pre-stressed cast iron, steel pipe

19

Economics in Power Markets

- **Competitive wholesale market options (e.g., ERCOT, PJM, CAISO)**
 - Low dispatch order: low fuel costs (heat from reactor), low VO&M, no emissions
 - Could replace capacity from older natural gas and fuel oil boiler units (feedback: could subsequently reduce peak prices)
 - Revenue from energy sales and reserves (ancillary services markets)
 - Needs decent price spread to be viable
 - Market uncertainty due to natural gas price volatility, wind and solar subsidies, environmental policies (e.g., carbon tax)
- **ERCOT market studies**
 - Capital costs are driven by power-related costs (steam turbine and generator) rather than energy-related costs (tank volume, et c.)
 - **Revenue** is driven by steam turbine **power** (generation), **ramp rate** (reserves)
 - Energy capacity benefit plateaus beyond 10 hours

20

Conclusions

- Steam accumulators are a **mature technology** and are available at **large scale** from multiple vendors
- Water is an excellent heat transfer fluid and heat storage medium that doesn't degrade with cycling
- Steam accumulators carry the **same risks as all boilers**
- The overall energy density is low (comparable to flywheels and CAES)
- Could be **retrofitted** to existing plants or **integrated** into new plant designs
- Greatest uncertainties are in future market opportunities and plant licensing

21

Acknowledgements

- U.S. Department of Energy, Office of Nuclear Energy
 - Nuclear Energy University Programs (Grant 14-6950): Univ. of Texas, MIT (Dr. Charles Forsberg)
 - Integrated University Program Fellowship
 - Idaho National Laboratory (Dr. Piyush Sabharwal)
- The University of Texas at Austin
 - Cockrell School of Engineering (Prof. Erich Schneider, Prof. Sheldon Landsberger)
 - Energy Institute

22

References

- Bell, Robert Purves (1888). *Andrew Betts Brown, 1839 - 1906. Engineer and inventor*. Oil on canvas. 76.2 cm × 63.50 cm. National Galleries of Scotland, Edinburgh. [Online]. Available: <https://www.nationalgalleries.org/art-and-artists/1902/andrew-betts-brown-1839-1906-engineer-and-inventor>
- Betts Brown, A. (Sept. 1870) "Hydraulic Machinery for Steering, Stopping, and Working Heavy Steam-engines discharging Cargo," 40th Mtg. *British Assn. Adv. Sci.*, Liverpool.
- Betts Brown, A. (1 Jun. 1874). "On Hydraulic Machinery for Steering, Reversing, and Discharging Cargo &c. in Steamships." *Proc. Inst. Mech. Eng.*, Birmingham.
- Dillinger (2016). "Dillinger heavy plate for the first solar power tower plant in South Africa." [Online]. Available: <https://www.dillinger.de/de/en/products/applications/boilers/references/dillinger-heavy-plate-for-the-first-solar-power-tower-plant-in-south-africa-68527.shtml>
- Gilli, P.V.; Fritz, K. (Oct. 1970). "Nuclear Power Plants with Steam Accumulators for Load Peaking." Presented at the IAEA Symp. Economic Integration of Nucl. Power Stations in Elect. Power Syst., Vienna. [Online]. Available: http://www.iaea.org/inis/collection/NCLCollectionStore/_Public/02/008/200873.pdf
- Gilli, P.V.; Beckmann, G.; Schilling, F.E. (Jun. 1977). "Thermal Energy Storage using Prestressed Cast Iron Vessels (PCIV)." Energy Research and Development Administration, Washington, D.C., Rep. COO/2886-2. doi:10.2172/5015636 [Online]. Available: <https://www.osti.gov/scitech/biblio/5015636-thermal-energy-storage-using-prestressed-cast-iron-vessels-pciv-final-report>
- Guy, A.E. (24 Oct. 1911). "Steam-power plant and the like." U.S. Patent 1,006,477.

23

References

- Han, W.; Hongguang, J.; Jianfeng, S.; Rumou, L.; and Zhifeng, W. (Oct. 2009). "Design of the First Chinese 1 MW Solar-Power Tower Demonstration Plant." *Int. J. Green Energy*, Vol. 6, no. 5, pp. 414–425.
- Kanakis-Wirtl, I. (Photographer). (Jan. 2005). *Berlin-Charlottenburg thermal power plant* [Digital image]. Available: <https://www.atsstructure.net/structures/charlottenburg-power-plant/photos>
- Lane III, R.E. (2016). "Modeling and Integration of Steam Accumulators in Nuclear Steam Supply Systems." Master's thesis. Dept. Mech. Eng. Univ. Texas at Austin. [Online]. Available: <http://hdl.handle.net/2152/45853>
- LaPotin, A.; Schneider, E.A. (Nov. 2016). "An Economic Model of a Steam Accumulator Storage System for Nuclear Power Plants." in *Trans. Amer. Nucl. Soc.* Vol. 115, Las Vegas, NV.
- Mann, W.N.; Schneider, E.A. (Nov. 2016). "Potential Ancillary Services Revenue for Nuclear Power Plants with Thermal Energy Storage." in *Trans. Amer. Nucl. Soc.* Vol. 115, Las Vegas, NV.
- Mann, W.N.; Schneider, E.A. (Jul. 2017). "Hybrid Nuclear Thermal Energy Storage System Revenue with Design and Market Uncertainty." in *Proc. 2017 25th Int. Conf. Nucl. Eng. (ICONE25)*, Shanghai, China.
- National Renewable Energy Laboratory (2017). "Concentrating Solar Power Projects." [Online]. Available: <https://www.nrel.gov/csp/solarpaces/index.cfm>
- Ruths, J. (25 May 1926). "Steam Plant," U.S. Pat. 1,585,791.
- Science News Letter (25 Oct. 1930). "Steam Accumulators Boost Power in Berlin." [Online]. Available: <https://www.sciencenews.org/article/October-25-1930-issue>
- Te-Gazarian, A.G. (1994). *Energy Storage for Power Systems*. Stevenage, Hertfordshire, UK: Peter Peregrinus Ltd.
- Thomson, Sir W. (Nov. 1881). "On the Sources of Energy in Nature Available to Man for the Production of Mechanical Effect." *J. Franklin Inst.* Vol. 112, no. 5, pp. 376–385.

24

Disclaimers

- This material is based upon work supported under an Integrated University Program Graduate Fellowship
- Any opinions, findings, conclusions or recommendations expressed in this publication are those of the author(s) and do not necessarily reflect the views of the Department of Energy Office of Nuclear Energy

Heat Storage in Secondary Media

Dr. J. Michael Doster and Konor Frick
 Department of Nuclear Engineering
 North Carolina State University

Introduction

- Thermal Energy Storage (TES) systems have been proposed as a load management strategy for Small Modular Reactors (SMRs) operating under significant time varying electric loads
- The operating strategy involves operating the reactor at or near steady state and bypassing excess steam to a Thermal Energy Storage (TES) steam for recovery later
- Two tank sensible heat systems are a commercially mature technology and have been deployed in concentrated solar systems
- While demonstrated for SMR class systems, the approach is scalable to conventional LWR systems

Reactor Systems Model

- Capable of simulating IPWRs operating under forced and natural circulation
- Includes:
 - Reactor kinetics with overlapping rod banks, Xenon, fuel and moderator temperature feedback, decay heat
 - Hot channel model with CHF and peak fuel centerline temperature calculations
 - Pressurizer with heaters and sprays
 - Conventional and helical coil OTSGs
 - BOP
 - Associated control functions
- mPower sized forced convection system model has been developed
- NuScale sized natural circulation system model under development
- Modifications to allow steam coupling to TES systems have been completed

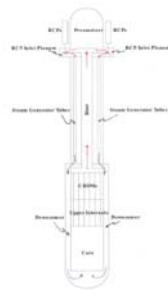

Bypass Steam Options

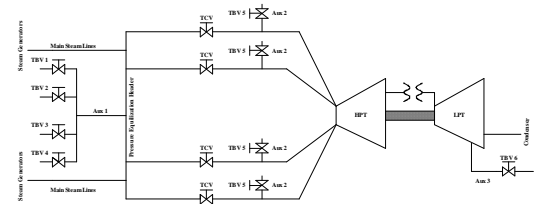

System Design

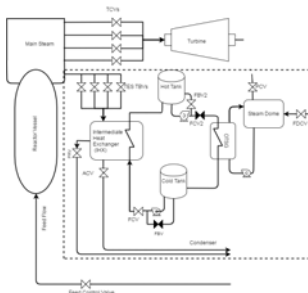

- Sensible heating design
- Proven track record in other energy fields
- 2 modes of operations: charging (shown) and discharging
- Bypass steam conditions dependent on connection point in energy conversion system
- Thermo-66 TES fluid

Operational Considerations

- Hot tank temperature limited to approximately saturation temperature of the steam source
- Bypass flow limited to approximately 45% of nominal steam flow (corresponds to shedding approximately 60% turbine load)
- Condensate from IHX can be drained to condenser or used as a heat source for low temperature/pressure applications, e.g. desalination or chilled water

Conclusions

- Demonstrates the feasibility of using TES systems coupled to Small Modular Reactors to minimize power swings during periods of variable electric load.
- Addition of a TES system can minimize effect of varying levels of renewable penetration.
- Such systems allow for a combined reactor/TES system where loads exceed nominal reactor capacity
- System can be optimized for any electric load profile
- Additional connection to ancillary applications can further increase the overall system efficiency
- While demonstrated for SMRs, the approach is scalable and applicable to current generation LWRs

Appendix

Reactor Characteristics

Parameter	Value
Reactor Thermal Output	530 Mwt
Electric Output	180 Mwe
Primary System Pressure	2050 psia
Core Inlet Temperature	566 F
Core Exit Temperature	611 F
Core Flow Rate	30 Mlbm/hr
Steam Pressure	825 psia
Steam Temperature	571 F (~50 degree superheat)
Feed Temperature	414 F
Steam Flow Rate	2.1Mlbm/hr
Number of Tubes	7048
Tube Material	Inconel-690
Tube Inner Diameter	0.523 inches
Tube Outer Diameter	0.687 inches
Pitch	0.824 inches

Thermal Energy Storage System Characteristics

Parameter	Value	Parameter	Value
TES Fluid	Therminol®-66	Mass of Hot Tank Fill Gas	3.225x10 ⁷ lbs
Hot Tank Volume	8,000,000 ft ³	Mass of Cold Tank Fill Gas	4.489x10 ⁷ lbs
Cold Tank Volume	8,000,000 ft ³	Temperature of Cooling Water	50F
IHX Reference Exit Temperature	500F	Volume of Condenser (Shell Side)	7607 ft ³
Number of TBV's	4	Number of Tubes in Condenser	76824
TES Maximum Steam Accommodation	~45% Nominal	Length of Tubes in Condenser	24.1ft
Pressure Relief Valve Upper Setpoint	780 psi	Mass Flow of Cooling Water	3.411x10 ⁷ lbs/hr
Pressure Relief Valve Lower Setpoint	760 psi	Condenser Tube Inner Diameter	0.044 ft
Turbine Header Pressure	825 psi	Condenser Tube Outer Diameter	0.058 ft
Shell Side (outer loop) IHX Volume	1171 ft ³		
Number of Tubes	19140		
Length of Tubes	36.9 ft		
Tube Inner Diameter	0.044 ft		
Tube Outer Diameter	0.058 ft		

Westinghouse Non-Proprietary Class 3 © 2017 Westinghouse Electric Company LLC. All Rights Reserved.

Westinghouse Heat Storage Investigations

Cory Stansbury
Senior Engineer
Innovation Center of Excellence- Advanced Mechanical Design
WAAP-10468



1

Westinghouse Non-Proprietary Class 3 © 2017 Westinghouse Electric Company LLC. All Rights Reserved.

Introduction and History of Westinghouse Energy Storage

- Energy storage project was initiated by Westinghouse's "Kick Start" innovation activity with involvement by FENOC
- Energy storage was evaluated for legacy LWR plants as a potential modification
- Subsequent investigations expanded to include new build AP1000 plants, with emphasis on utilizing existing equipment
- Most recently, the Westinghouse Lead Fast Reactor (LFR) program has included energy storage as an assumed feature
- We recognize the importance of providing flexible operation in the future



2

Westinghouse Non-Proprietary Class 3 © 2017 Westinghouse Electric Company LLC. All Rights Reserved.

Basis for Technology Selection

Technologies Considered	Criteria
<ul style="list-style-type: none"> • Compressed Air Energy Storage • Cryogen Energy storage • Thermal storage • Batteries • Hydrogen • Pumped hydro • Desalination • District heating • Synthetic fuel 	<ul style="list-style-type: none"> • Plant Integration • Economics • Demand responsiveness • Footprint • Geographic independence • O&M feasibility • Environmental impact • Competitive landscape • Capital cost • Scalability





3

Westinghouse Non-Proprietary Class 3 © 2017 Westinghouse Electric Company LLC. All Rights Reserved.

Energy Storage Module

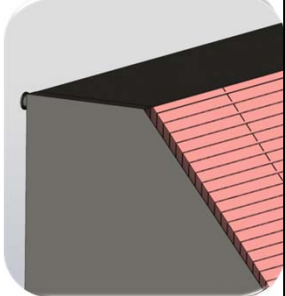
- Concept:
 - Steel module factory assembled in bulk
 - Cast concrete slabs slide into slots
 - Concrete has micro rebar or other similar admixture
 - Cast-in thermal breaks
 - Low fluid velocity, high HXR area, and short HXR distance through concrete
- Benefits:
 - No piping
 - Very low-cost materials
 - Able to utilize positive properties of concrete
 - Low velocities reduce pumping power, erosion, and HXR fluid volume
 - "Engineered" system
 - Modular with thermal mass added at site
 - Temperatures below oil's flame point
- Challenges
 - Concrete/oil interaction
 - Perfecting manufacturing to achieve consistent tolerances
 - Long-term cycling performance
 - Reliable BoP integration

4

Westinghouse Non-Proprietary Class 3 © 2017 Westinghouse Electric Company LLC. All Rights Reserved.

Energy Storage Module



Two 1 MWh Energy Storage Modules Fit on a Standard Trailer



5

Westinghouse Non-Proprietary Class 3 © 2017 Westinghouse Electric Company LLC. All Rights Reserved.

Energy Storage Module



Seven 1 MWh Energy Storage Modules Fit on a Standard Trailer in Stacked Configuration





6

Westinghouse Non-Proprietary Class 3 © 2017 Westinghouse Electric Company LLC. All Rights Reserved.

Integration into LWRs

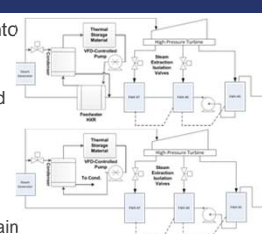
- For new construction, can tie into existing turbine/generator
 - Displace feedwater heating
 - Requires oversized turbine and generator
 - Slight loss of turbine efficiency during baseload (~1%)
 - Use steam based heating to increase effectiveness of concrete and simplify FWH chain
- For existing plants
 - Use main steam to heat
 - Use extracted heat to power Aux TG

Westinghouse 7

Westinghouse Non-Proprietary Class 3 © 2017 Westinghouse Electric Company LLC. All Rights Reserved.

Design Capabilities

- Sizing for existing plants has been based on:
 - 1 GWh of electrical storage
 - 200 MWe charging rate
 - 100 MWe discharge rate
- Sizing for new construction aims for charge and discharge rates of 20-25% that of plant output
- Round trip efficiency modeled around 60% with opportunity for improvement
- Existing plants more limited due to existing hardware
- Highly expandable

Inexpensive, plentiful storage is possible

Westinghouse 8

Westinghouse Non-Proprietary Class 3 © 2017 Westinghouse Electric Company LLC. All Rights Reserved.

Lead Fast Reactor

- Westinghouse has been working on an LFR for ~2 years
- Part of the LFR concept has been integrated energy storage
- Current plant is sized around 400 MWe
- Energy storage capacity of 500-600 MWh is estimated, based on California demand response
- Investigations also underway to tie into solar collector-based feedwater heating
 - Reduces overall storage need slightly while increasing effective plant size
 - Marginal costs of reflectors only significant added cost
 - Shows economic promise in certain markets/geography

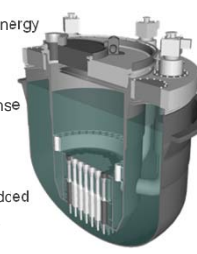

Nuclear Power and Renewables Can Play Nicely Together!

Westinghouse 9

Westinghouse Non-Proprietary Class 3 © 2017 Westinghouse Electric Company LLC. All Rights Reserved.

Conclusions

- Westinghouse energy storage modules use low-cost materials and standard manufacturing
- Use of concrete allows for thermal mass to be manufactured/added at site
- Due to modular design, system is scalable
- No geographic dependency
- Can be applied to existing plants, new construction, or future technologies
- Shows significant promise to be one of the least expensive energy storage options
- Allows nuclear power to generate additional profits AND be complementary to renewable technology

Westinghouse 10

Westinghouse Non-Proprietary Class 3 © 2017 Westinghouse Electric Company LLC. All Rights Reserved.

Questions?

Westinghouse 11

Westinghouse Non-Proprietary Class 3 © 2016 Westinghouse Electric Company LLC. All Rights Reserved.

Nuclear Energy Storage

OVERVIEW + UPDATE

- Evaluation of technologies and down-selection: **Completed**
- Intellectual property search: **Completed**
- Preliminary financial evaluation using Sandia ES-Select Software: **Completed**
- Attendance of multiple energy storage conferences in U.S. and Europe: **Completed**
- Preliminary Licensing and Systems impact evaluations: **Completed**
- Conceptual design and feasibility studies: **Nearing completion**
- Modeling efforts using both commercial software and a new internal code: **Ongoing**
- High-level pricing estimate and identification of cost-saving areas of focus: **Ongoing**
- Partnership with Georgia Tech School of Civil and Environmental Engineering on concrete: **Initiated**

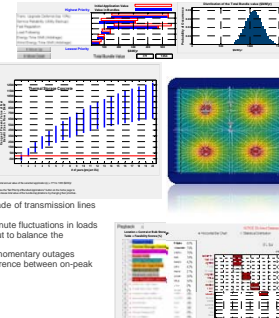

BENEFITS: Main market services

- Transmission Upgrade Deferral:** Defer the installation/upgrade of transmission lines and substations
- Fast Regulation:** Change output quickly to track minute-to-minute fluctuations in loads
- Load Following:** Load following capacity that adjusts its output to balance the generation
- Service Reliability Support:** Back-up power to ride-through momentary outages
- Energy Time Shift (Arbitrage):** Take advantage of price difference between on-peak and off-peak hours
 - Demand pricing
 - Solar
 - Wind

Westinghouse 12

Integration of Cryogenic Energy Storage with Nuclear Power Generation for Peak Shaving / Load Shift

Yulong Ding

Birmingham Centre for Energy Storage (BCES), University of Birmingham

www.birmingham.ac.uk/energystorage; y.ding@bham.ac.uk

© Professor Yulong Ding, University of Birmingham



- **Cryogenic energy storage (CES) technology**
 - Basic principle, brief history, flow diagram and application range
 - CES Pilot plant performance
 - Comparison of CES with other major large scale energy storage technologies
- **Integration of CES with Nuclear Power Plant (NPP)**
 - Integration of CES with NPP
 - Operation modes of the integrated CES-NPP system
 - Performance of the integrated CES-NPP system
- **Specific Q&As for the integrated CES-NPP system**
 - Status of the integrated CES-NPP technology
 - Special challenges in the CES-NPP technology
 - Peak shaving / load shifting capacity
 - Economic aspects

- **Cryogenic energy storage (CES) technology**
 - Basic principle, brief history, flow diagram and application range
 - CES Pilot plant performance
 - Comparison of CES with other major large scale energy storage technologies
- **Integration of CES with Nuclear Power Plant (NPP)**
 - Integration of CES with NPP
 - Operation modes of the integrated CES-NPP system
 - Performance of the integrated CES-NPP system
- **Specific Q&As for the integrated CES-NPP system**
 - Status of the integrated CES-NPP technology
 - Special challenges in the CES-NPP technology
 - Peak shaving / load shifting capacity
 - Economic aspects

- Energy storage– liquefaction of air using **off-peak/renewable electricity** with liquid air as the major energy storage medium
- Energy release – vaporization of liquid air using **ambient/renewable/waste heat** gives 700 times expansion to drive turbine producing electricity

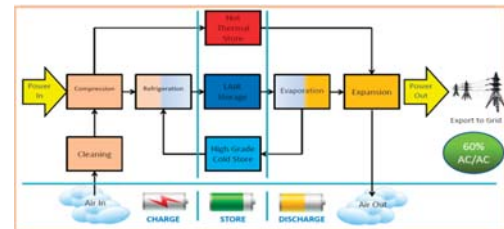

- Materials flow - Air in; Air out
- Energy flow - Electricity in; Electricity, heat and cold out
- Storage methods - Liquid air (major); Heat and cold (ancillary) with the heat from compression and cold from waste cold recovery

The idea of using liquid air as an energy storage medium was proposed **in the 19 century**

The concept of liquid air energy storage for peak shaving was first proposed **in the UK in 1977**

University of Leeds - Highview

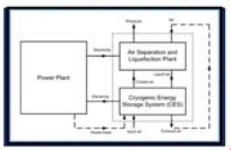

Liquid air energy storage combined with gas turbine power generation



Stand alone liquid air energy storage system



On 1 October 2013, The liquid air energy storage research team and equipment moved to University of Birmingham

The most advanced CES technology: currently in commercial demonstration stage after over 12 years of development



5MW/15MWh Commercial Demonstration in Manchester (2015-2018)



200MWh/1.2GWh CES system (2018 - 2023)

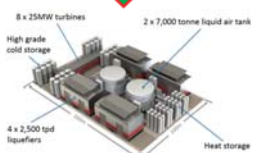

CES: Application Range (I)

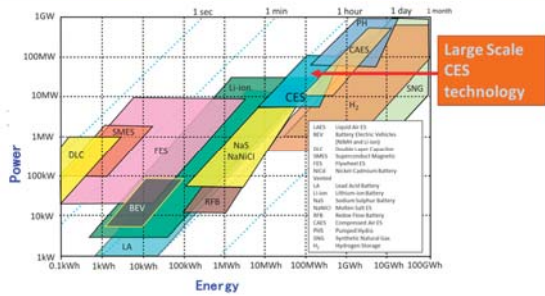

- Large scale CES technology suits mainly for energy related applications
- But can also be used for power related rapid response applications

BCES

7

CES: Application Range (II)

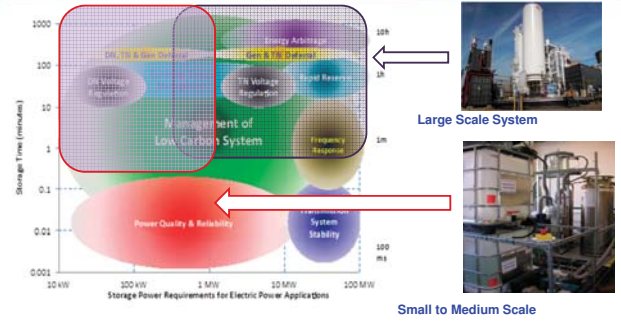

- Large scale applications - e.g. to partially replace pumped hydro
- Small scale applications – e.g. distributed energy systems and backup power
- Possible applications – e.g. frequency regulation

BCES

8

CES: Pilot Plant Tests (I)

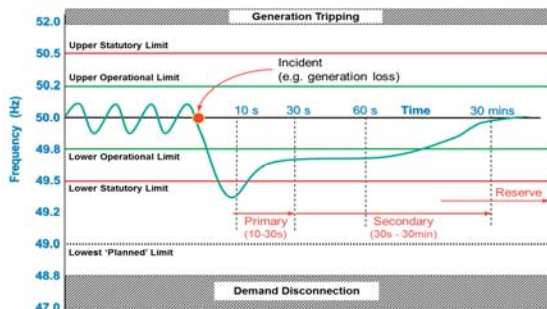

- Quick response of liquid air energy storage, much faster than compressed air energy storage and pumped hydro
- Secondary frequency control and possibly primary frequency control if running on the Spin Gen mode

BCES

9

CES: Pilot Plant Tests (II)

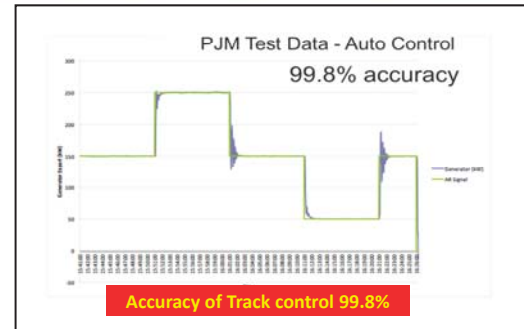

High dynamic response rate with high accuracy

BCES

10

CES: Pilot Plant Tests (III)

High efficiency in the utilisation of low grade heat

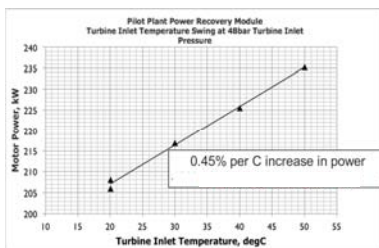

- Highly efficient utilization of low grade heat – an increase of 1°C gives an increase in power generation efficiency by 0.45%, this cannot be achieved by any other storage technologies
- Benefits for the integration of CES with NPP

BCES

11

CES: Space requirements

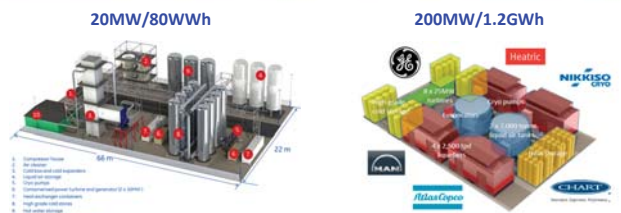

- A 200MW/1.2GWh system takes ~16000m² space
- A 20MW/80MWh system takes ~1600m² space
- A 5MW/15MWh system takes ~1000m² space
- A 350kW/2.5MWh system takes ~500m² space

BCES

12

Capital investment of CES

Daily Cycling Unit			FOR (1 st)	FOR (5 th)	FOR (10 th)	10 th (1 st)	10 th (5 th)	10 th (10 th)
PBU	Liquefaction	Tank + HGCS						
10MW	4MW (480 tonne/day)	85.7 MWh (857 tonne)	34.1	3,410	852.5	18.83	1,883	471
50MW	20MW (2,400 tonne/day)	428.6 MWh (4,286 tonne)	92.46	1,849	462	52.36	1,047	262
200MW	80MW (9,600 tonne/day)	1,714MWh (17,143 tonne)	221.38	1,106	276.5	129.6	648	162

- An increase in the scale leads to a significant cost reduction
- For a given scale, the 10th unit **only costs 1/3 of the first unit**

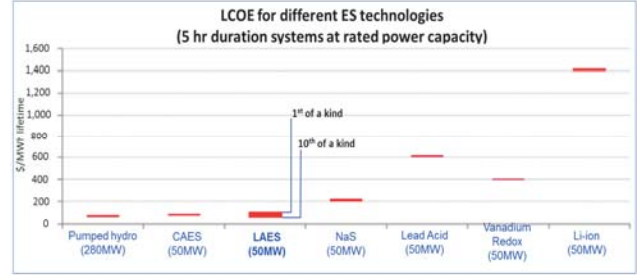

$$LCOE = \frac{\text{sum of costs over lifetime}}{\text{sum of electricity produced over lifetime}} = \frac{\sum_{t=1}^n \frac{C_t + M_t + F_t}{(1+r)^t}}{\sum_{t=1}^n \frac{E_t}{(1+r)^t}}$$

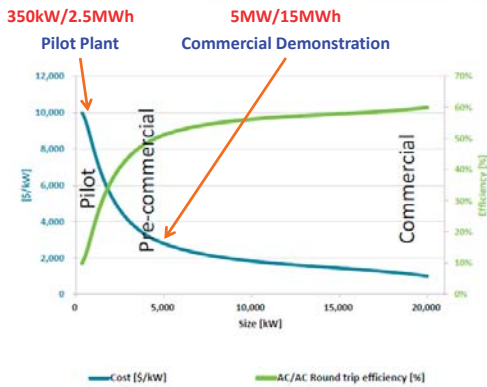

Storage method	Energy density Wh/L	Life span	Round trip efficiency %	Capital cost USD/kW	LCOE cost USD/kWh	Storage time	Geological conditions	Technology maturity
Pumped Hydro	0.5-1.5	40 - 60	60-80	600-2000	0.05-0.1	Hours - Months	Strict requirements	Mature
Compressed Air	3-6 (30-300bar)	20 - 40	40-50 No heat recovery 60-70 With heat recovery	600-1300 2000-3000	0.08-0.15	Hours - Months	Strict requirement	Developed Under development
Liquid air	60-120 (No pressure effect)	30 - 40	40-70 No heat recovery 60-100 With heat and cold recovery	650-2000	0.05-0.15	Hours - Months	No requirement	Nearly Developed

Battery LCOE cost: lithium ion ~\$1.4/kWh; sodium-sulfur ~\$0.2/kWh; lead-acid ~\$0.6/kWh; Flow batteries ~\$0.4/kWh

Contents

- Cryogenic energy storage (CES) technology
 - Basic principle, brief history, flow diagram and application range
 - CES Pilot plant performance
 - Comparison of CES with other major large scale energy storage technologies
- Integration of CES with Nuclear Power Plant (NPP)
 - Integration of CES with NPP
 - Operation modes of the integrated CES-NPP system
 - Performance of the integrated CES-NPP system
- Specific Q&As for the integrated CES-NPP system
 - Status of the integrated CES-NPP technology
 - Special challenges in the CES-NPP technology
 - Peak shaving / load shifting capacity
 - Economic aspects

NPP in the World (May 2017)

- 449 commercial NPP operable in 31 countries, >390,000 MWe of total capacity
- About 60 more reactors are under construction
- Provide over 11% of the world's electricity as continuous, reliable base-load power, without carbon dioxide emissions

NPP in commercial operation

Reactor type	Main countries	Number	GWe
Pressurized water reactor (PWR)	US, France, Japan, Russia, China	282	264
Boiling water reactor (BWR)	US, Japan, Sweden	78	75
Pressurized heavy water reactor	Canada, India	49	25
Gas-cooled reactor (AGR)	UK	14	8
Light water graphite reactor (LWGR)	Russia	11 + 4	10.2
Fast neutron reactor (FBR)	Russia	3	1.4
TOTAL		441	384

Light Water Reactors - >80% total capacity

Integration of CES with NPP (II)

Light Water Reactor (Pressurized Water Reactor)

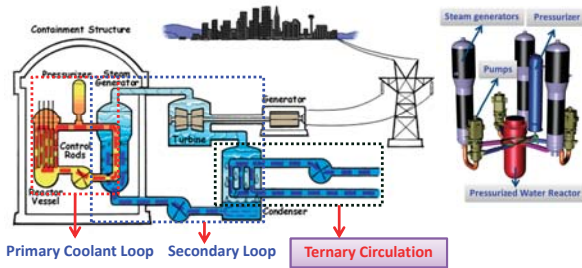

- P and T in primary loop ($\sim 15.5\text{MPa}$, $\sim 340^\circ\text{C}$) & secondary loop ($\sim 7\text{MPa}$, $\sim 260^\circ\text{C}$)
- Thermal efficiency $\sim 35\%$

BCES

19

Integration of CES with NPP (III)

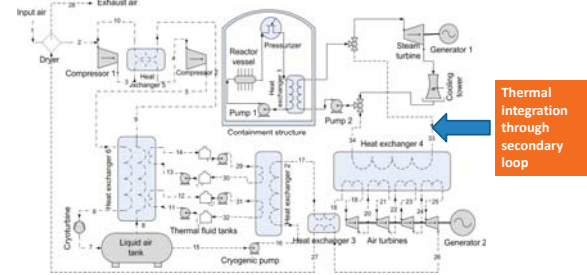

- **Energy storage mode** at trough hours: NPP operates in a traditional way to produce electricity; excessive power is used to produce liquid air;
- **Energy release mode** at peak hours, both NPP and CES energy extraction unit are turned on to produce power;
- **Conventional mode** at non-trough and non-peak hours, CES off, NPP operates in a conventional manner.

BCES

Integration of CES with NPP (IV)

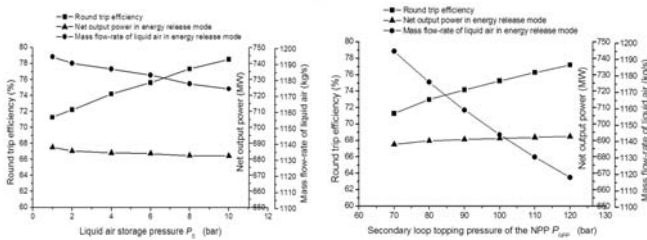

- Assuming a rated power of LWR of 250MW, the integrated CES-NPP system gives a **peak shaving capacity** approximately **2.7 times the NPP rated power**
- The **CES round trip efficiency** is $\sim 75\%$

BCES

Contents

- Cryogenic energy storage (CES) technology
 - Basic principle, brief history, flow diagram and application range
 - CES Pilot plant performance
 - Comparison of CES with other major large scale energy storage technologies
- Integration of CES with Nuclear Power Plant (NPP)
 - Integration of CES with NPP
 - Operation modes of the integrated CES-NPP system
 - Performance of the integrated CES-NPP system
- **Specific Q&As for the integrated CES-NPP system**
 - Status of the integrated CES-NPP technology
 - Special challenges in the CES-NPP technology
 - Peak shaving / load shifting capacity
 - Economic aspects

BCES

22

Specific Q&As for the integrated CES-NPP system

- Status of the integrated CES-NPP technology
 - CES in commercial demonstration stage
 - Performance and capital investment and performance of integrated CES-NPP evaluated
- Special challenges in the CES-NPP technology
 - Safety concerns over the secondary loop integration
 - Conservative of the nuclear industry
- Peak shaving / load shifting capacity
 - ~ 2.7 times the rated power of the NPP
- Economic aspects
 - The capital investment is $\sim 30\%$ of pumped hydro, and $\sim 5\%$ of batteries



Background Packed beds Steam in packed beds

Packed Bed Thermal Energy Storage for Light Water Reactors

Hitesh Bindra
Kansas State University

Heat Storage-Focused Workshop on Near-Term Options

1

Background Packed beds Steam in packed beds

Table of contents

- 1 Background
- 2 Packed bed thermal storage
- 3 Steam injection in packed beds

2

Background Packed beds Steam in packed beds

TES solution for existing NPPs

Thermal Energy Storage (TES) - Naturally compatible with Nuclear Power as we generate energy through release of heat.

3

Background Packed beds Steam in packed beds

Options and Challenges

- Top operating temperature i.e. Reactor outlet coolant temperature ~ 590 K.
- Economics of sensible heat storage solutions is dependent upon the temperature differential which can be achieved.
- Molten salt (nitrates salts) have melting point ~ 490 K.
- Dowtherm or Therminol can operate through the range of temperatures, but are expensive (\$150 /kWhr(e))

4

Background Packed beds Steam in packed beds

Integration with LWRs

LW-SMRs are very compact as compared to LWRs; Steam generation within Reactor Pressure Vessel.

5

Background Packed beds Steam in packed beds

Packed bed TES system

Figure: Packed bed storage system (Bindra,2013)

6

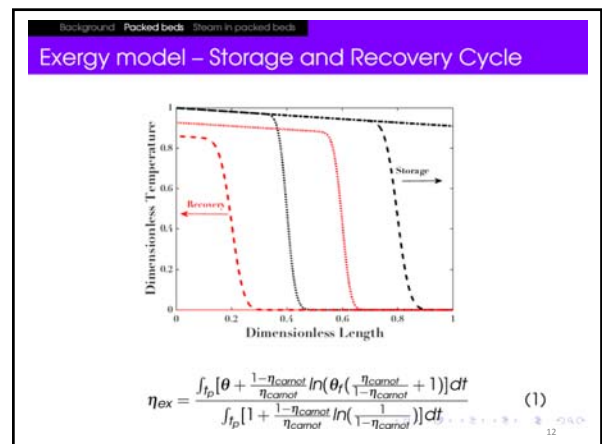
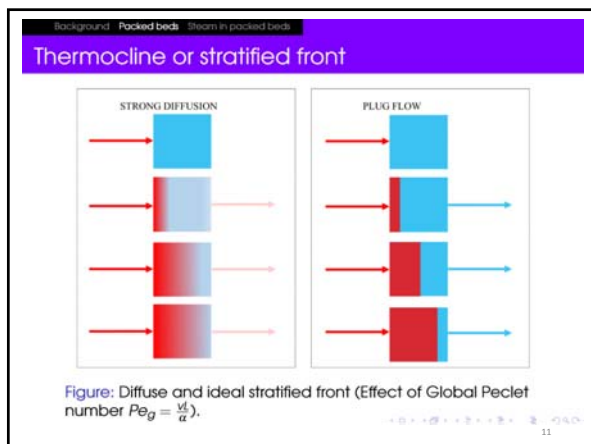
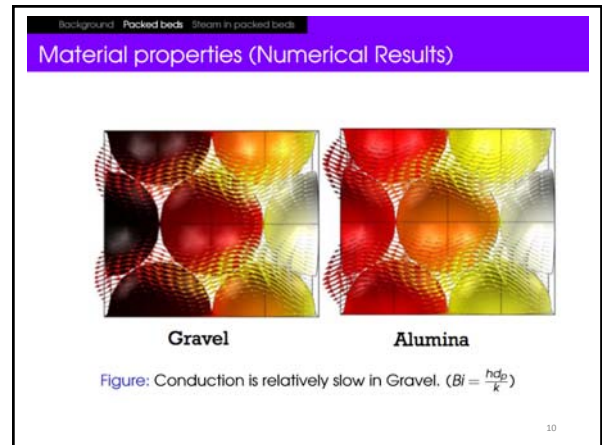
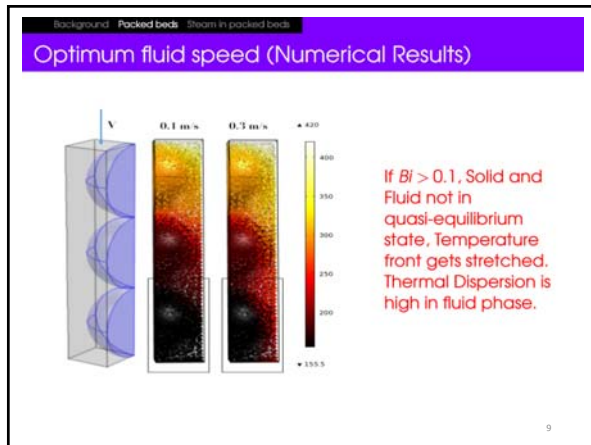
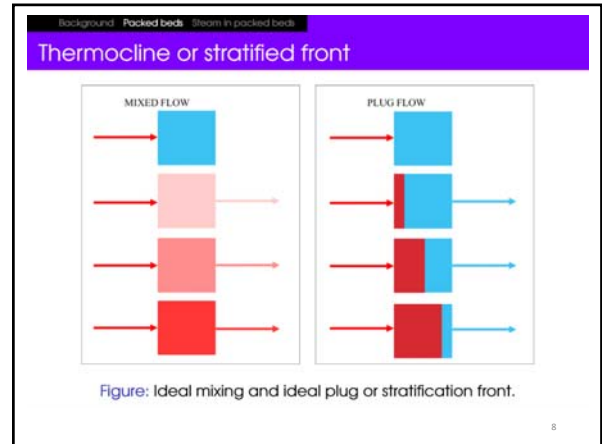
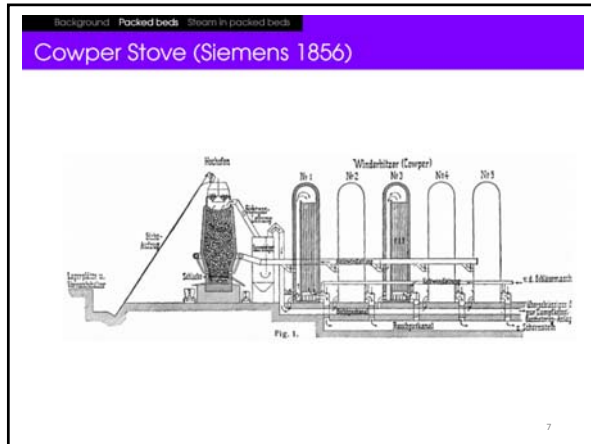

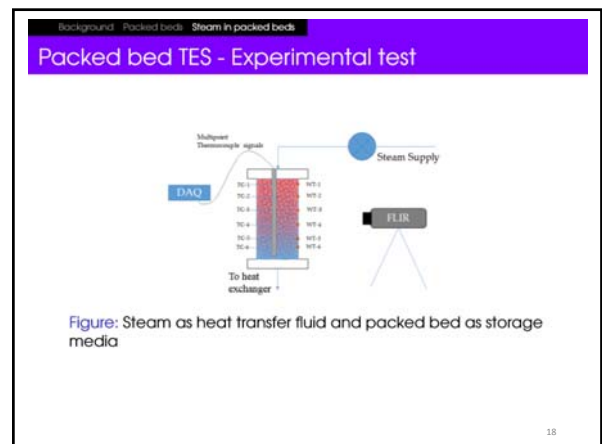
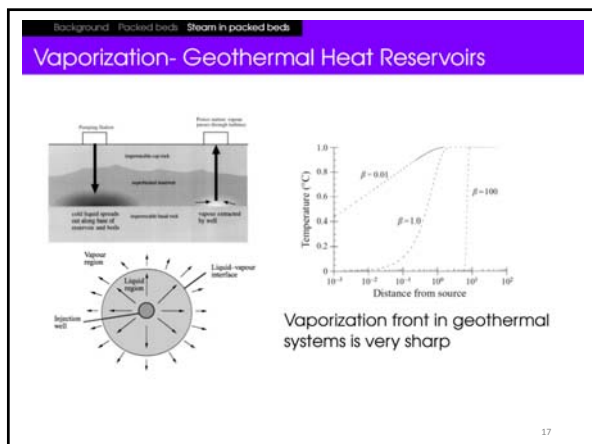
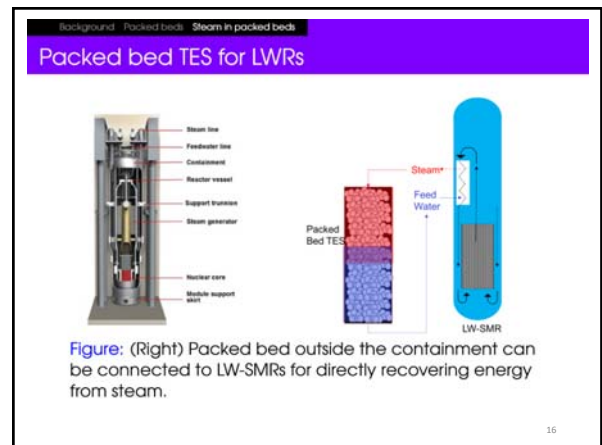
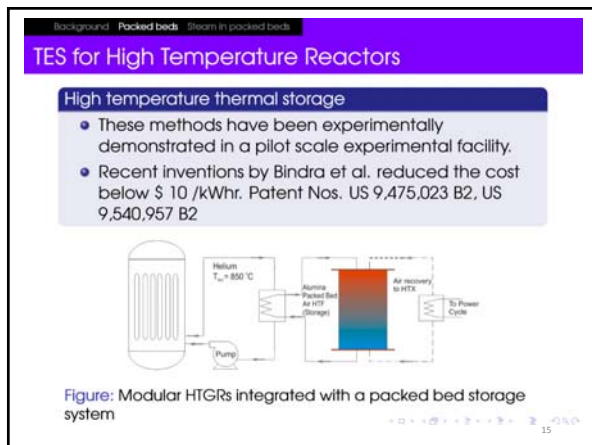
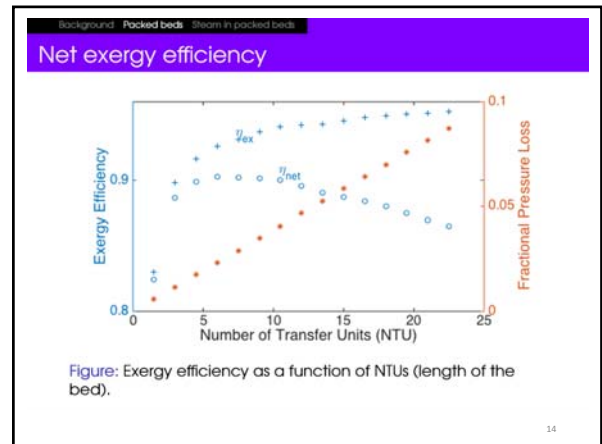
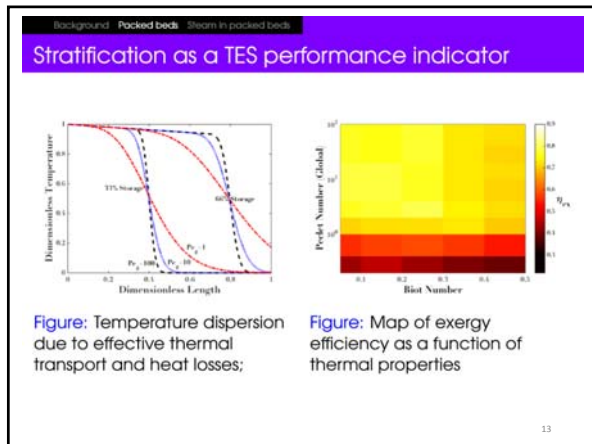

Background Packed beds Steam in packed beds

Packed bed TES - Experimental test

Figure: Steam as heat transfer fluid and packed bed as storage media (X-ray and IR images at every 10 secs)

19

Background Packed beds Steam in packed beds

Packed bed TES - Experimental test

Figure: Temperature measurements in the bed using profile thermocouple probes

20

Background Packed beds Steam in packed beds

Spatial Temperature Profile – Fiber Optics

- System measures fiber scatter pattern
- Compare scatter patterns to determine strain
 - $\Delta \lambda$ = mean period between perturbations
 - Strain or temperature change $\rightarrow \Delta \lambda$ change

21

Background Packed beds Steam in packed beds

Stratification due to Packed bed TES

Figure: Temperature profiles at different times in: (Left) Injecting hot water in a water-filled chamber; (Right) Injecting hot water in packed bed and cold water

22

Background Packed beds Steam in packed beds

Stratification during steam injection experiments

Figure: Temperature profiles at different times in: (Left) Fast injection leads to sharp front (Right) Slow injection shows heat conduction in condensate hold-up region

23

Background Packed beds Steam in packed beds

Low pressure scaled down test setup

14 Gallon Scale test setup performance
Bindra et al. (PCT/US2017/033566)

24

Background Packed beds Steam in packed beds

Practicality of packed bed TES with steam as HTF

Thermal dispersion and storage density
 Temperature gradients are much sharper in the packed bed as compared to the water tank with comparable energy density.

Energy density in Alumina and other materials
 Pea-gravel perform in exactly same manner as Alumina. Energy density in NPPs is lower than high temperature TES, but costs of pea-gravel are much lower.

Costs of packed bed TES
 The costs with vessel, materials, piping and auxiliaries are expected to be \$ 30/kWh(e) for LWR operating range.

25

Background Packed beds Steam in packed beds

Conclusions

- There is a need for TES system to directly recover energy from steam.
- Packed bed TES have been tested experimentally with direct steam injection system.
- Sharp temperature gradients of thermal stratification play critical role in defining the performance of packed bed TES systems.
- Energy density of using packed bed TES with pea gravel in the temperature range of existing NPPs is $\sim 2kWhr(e)/ft^3$.
- Potential for more than electricity production with the ease of transportability.

26

Background Packed beds Steam in packed beds

Acknowledgments

- Jacob Edwards, graduate student at Kansas State University
- Partial support from National Science Foundation
- Colleagues and Mentors at CUNY Energy Institute

27

Background Packed beds Steam in packed beds

References

- R. Shinnar, H. Bindra, Thermal Energy Storage for Combined Cycle Power Plants, 2017 (Patent No. US 9,540,957 B2)
- H. Bindra, P. Bueno (Patent No. US 9,475,023 B2)
- J. Edwards, H. Bindra, P. Sabharwall, Annals of Nuclear Energy, 96, 2016
- H. Bindra, P. Bueno, J.F. Morris, R. Shinnar, Appl. Therm. Eng. 52, 2013, pp.255-263.
- H. Bindra, P. Bueno, J.F. Morris, Appl. Therm. Eng. 54, 2014, pp.201-208.
- A. Woods et al., The vaporization of a liquid front moving through a hot porous rock, J. Fluid Mech. (1997), vol. 3443, pp. 303–316
- H. Bindra, J. Edwards, D. Gould, U.S. Patent Application No. 62/339,576 (International Patent Application No.PCT/US2017/033566)

28

Atmospheric-Pressure Crushed-Rock Heat Storage

Nathaniel McLauchlan

Ensign, USN

Technology and Policy Graduate Student; Massachusetts Institute of Technology
Tel: (512) 587-8743; Email: nmclauch@mit.edu

June 2017

Overview

- Filling a technology gap
- System overview
- Distinguishing features
- Status of the technology
- Next steps
- Takeaways

Filling a Technology Gap

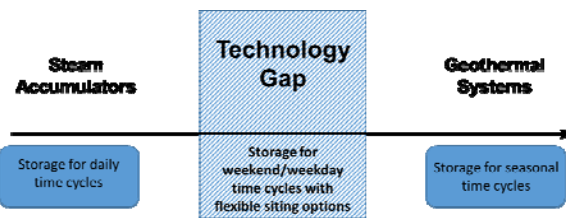

System Overview

System Technical Overview

- Air is heated using a condensing steam-air heat exchanger or resistance heaters
- Heated air flows down the pile of crushed rock in the heating mode
- Air flow is reversed to recover heat

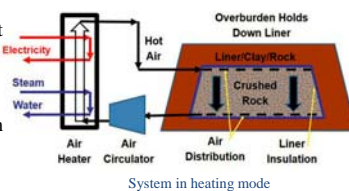

Conceptual Model of Electricity-flow

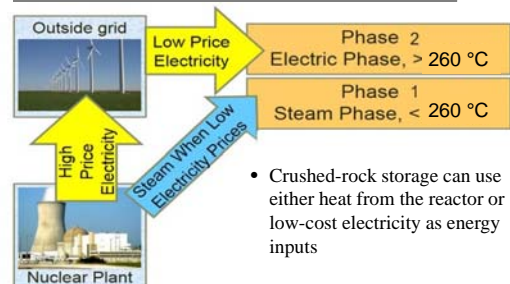

- Crushed-rock storage can use either heat from the reactor or low-cost electricity as energy inputs

Options for Discharge

- *Stand-alone steam plant* – efficiencies near 45%
- *Steam to nuclear turbine* – requires an oversized turbine
- *Advanced power cycles* – e.g. supercritical carbon dioxide Brayton cycles

Expected Technical Parameters

- Storage on the order of gigawatt-hours
 - E.g. granite with 30% void fraction could store ~10 GW·h of heat in a volume the size of a football field 30 m high (90 KW·h/m³)
- Operating temperature range of rock: 50-250 °C
- Operates at or slightly above atmospheric pressure
- Range of electric output will depend on the grid and the market – likely 250MW-1300MW

Distinguishing Features

Distinguishing Features

- Expected storage on the order of gigawatt-hours
- Few siting constraints (unlike geothermal systems)
- Extremely low expected marginal cost
 - Substantially lower than \$1/kW·h
 - Allows for both large energy storage capacity and cost-effective scalability

Dual-Use Applications in Industry

- Stored heat can provide:
 - Electric supply at peak demand
 - Hot air for industrial furnaces

Status of the Technology

Status of the Technology

- Only theoretical, but relies on scaling up well-understood technologies
- Deployable in 10-15 years, but time to deployment is dependent on urgency, not innovation
- Red Leaf Resources is currently developing a similar technology for the recovery of shale oil

Red Leaf Resources

- Oil-shale company based in Salt Lake City, UT



Red Leaf Resources System

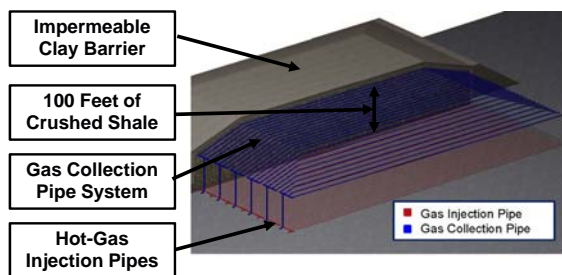

Significant Difference in Objectives

- Crushed-rock heat storage will be subject to multiple heating cycles

Next Steps

- Determine thermodynamic parameters
- Establish more robust economic estimates using combined thermodynamic and economic models

Crushed-rock Takeaways

- May provide an economically favorable, scalable energy storage system
- Could fill a technology gap for weekend/weekday storage
- Limited siting constraints
- Potential for dual-use applications in industry
- Employs use of relatively simple technologies

References

- C. W. FORSBERG, "Light-Water-Reactor Renewable Shale-Oil Systems for Variable Electricity Production and Liquid Fuels", Paper 6191, *Transactions American Nuclear Society Annual Meeting*, San Diego, California; November 11-15, 2012.
- C. W. FORSBERG, "Light-Water-Reactors with Crushed Rock Thermal Storage for Industrial Heat and High-Value Electricity", *Nuclear Technology*, 1981, 70-78
- Redleafinc.com

Nuclear-Geothermal Heat Storage

Charles Forsberg¹ / Thomas Buscheck²

Light Water Reactor Heat Storage for Peak Power and Increased Revenue

Salon T, Samberg Conference Center, Building E52 7th floor, MIT Campus
Cambridge, Massachusetts
June 27-28, 2017

¹Department of Nuclear Science and Engineering; Massachusetts Institute of Technology
77 Massachusetts Ave; Bld. 24-207a; Cambridge, MA 02139; Tel: (617) 324-4010;
Email: cforsber@mit.edu; <http://web.mit.edu/nse/people/research/forsberg.html>

²Lawrence Livermore National Laboratory, P.O. Box 808, L-223 Livermore, CA 94551
Email: buscheck1@llnl.gov



Overview

- “Traditional” Nuclear Geothermal
 - (MIT/Forsberg)
- Earth Battery
 - (LLNL/Buscheck)



2

Filling a Technology Gap

- Enable hourly to seasonal energy storage
 - Wind and solar seasonal
 - Power demand seasonal
 - Avoids concerns about reactor shutdown for refueling or any other reason
- Strategic national heat reserve
 - Today we have a strategic oil reserve
 - What replaces strategic energy reserves in a low-carbon system against the unexpected
 - Cut off of energy supplies (imported hydrogen?)
 - Low solar (volcanic activity) or wind (hurricane?)



3

System Overview

Traditional Nuclear Geothermal
Charles Forsberg (MIT)



4

Geothermal Heat Storage System

Create Artificial Geothermal Heat Source

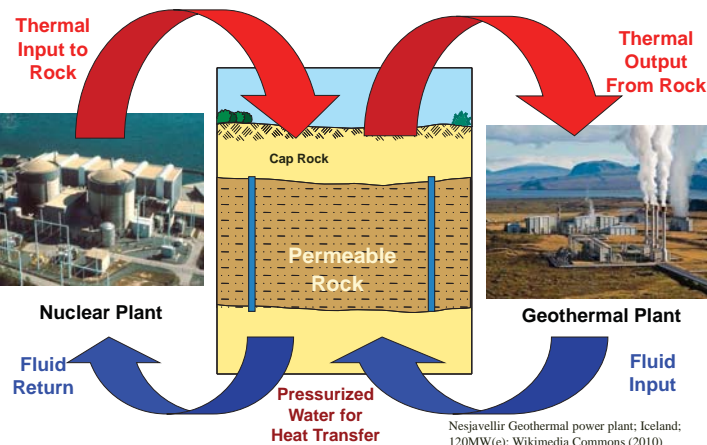

5

Nuclear-Geothermal Storage Is Based On Two Existing Technologies

Recovery of Heavy Oil By Reservoir Heating
California and Canada

Geothermal Power Plant Heat Extraction

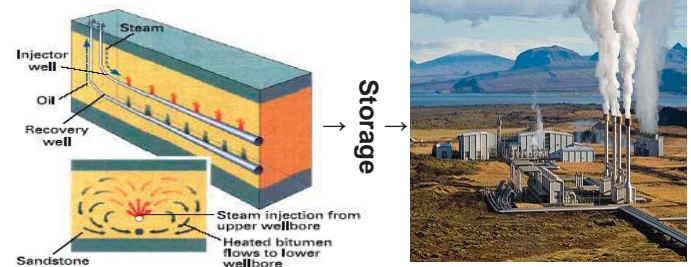
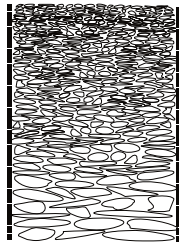
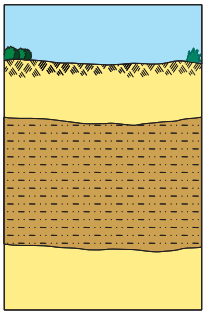

Figure courtesy of Schlumberger; Nesjavellir Geothermal power plant, Iceland: 120MW(e); Wikimedia Commons (2010)

6

Options to Create Permeable Rock

Chose Right Geology Create Permeable Geology Cave-Block Mining



Oil and Gas Reservoirs:
Initial Operation for Oil
Recovery and Heat Storage

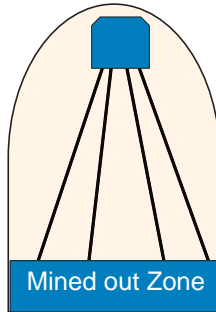

Distinguishing Features

Technical Constraints

- Couples efficiently with light water reactor; but, much above 300C and increasing rock solubility with temperature creates major challenges
- Require sufficient depth to maintain water in liquid state



Heat Storage Must Be Large to Avoid Excessive Heat Losses

Intrinsic Large-Scale Nuclear Storage System

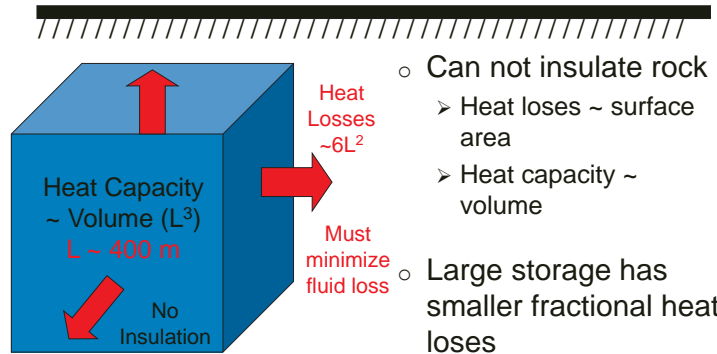

Fractional Energy Loss for Three Reservoir Sizes: Minimum Size ~0.1 GW-year

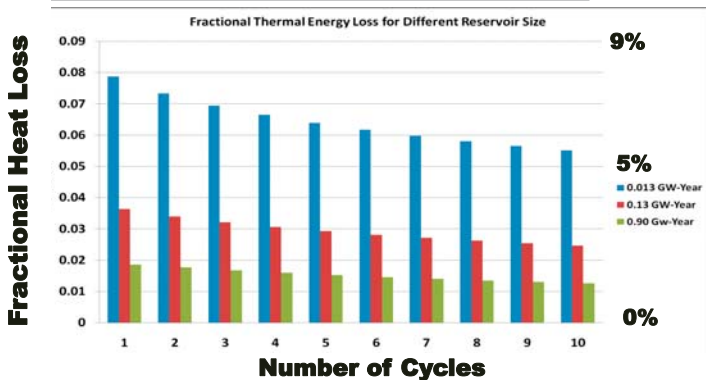

Fixed Parameters Inlet Temp. 250°C, Outlet Temp. 30°C, Porosity 0.2, D/L = 0.331, Cycle Length = 6 months

Status of the Technology

Limited Studies
Economics Favorable in Parts of the U.S.

Current MIT Research Efforts

Initial Estimated Round Trip Efficiency Up to 46%

- Low efficiency primarily because assumed geothermal power cycle efficiency is 20% (current geothermal) vs. 33% for PWR
 - Based on existing small geothermal plants
 - Scale up by factor of 10 to 100 enables more efficient power-cycle designs (triple flash versus double flash, etc.)
 - Nuclear geothermal “cleans” reservoir and reduces trash with potentially major efficiency gains relative to natural geothermal
 - Reduces non-condensable gases (carbon dioxide, hydrogen sulfide, etc.)
 - Dissolved solids removal
- Secondary losses in heat exchanger with scaling
 - Examining jet pump for pressure and heat addition (No Heat Exchanger)
 - Does require makeup water for nuclear plant steam generator
- Goal: >70% round trip efficiency (Possibility of 80%)

Earth Battery

Tom Buscheck (LLNL)

Earth Battery

Thomas A. Buscheck

Atmospheric, Earth, and Energy Division, Lawrence Livermore National Laboratory,
 P.O. Box 808, L-223, Livermore, CA USA

buscheck1@llnl.gov

June 27, 2017

Massachusetts Institute of Technology, Cambridge, MA USA

This study was funded by the U.S. Department of Energy (DOE) Geothermal Technologies Office (GTO) under grant number DE-FOA-0000336, managed by Sean Porse and Elisabet Metcalfe, and a U.S. National Science Foundation (NSF) Sustainable Energy Pathways (SEP) grant (1230691).

LLNL-PRES-733566

This work was performed under the auspices of the U.S. Department of Energy by Lawrence Livermore National Laboratory under contract DE-AC52-07NA27344. Lawrence Livermore National Security, LLC



The flexibility of the Earth Battery makes it an ideal match for nuclear power

- Energy is stored as pressure and heat in sedimentary rock (half of U.S.) using various supplemental working-fluid options (air, N₂, CO₂) and brine
- Overpressure (artesian pressure) is created by the net storage of supplemental working fluid
 - Geologic CO₂ storage (GCS) provides “free” overpressure
 - Compressed supplemental working-fluid energy storage, such as compressed air energy storage (CAES), stores excess electricity
- Thermal energy sources can be combined
 - Geothermal heat
 - Waste/excess heat from above-ground sources (solar, nuclear, fossil energy)
 - Waste heat of gas compression (major improvement over conventional CAES)

Lawrence Livermore National Laboratory

LLNL-PRES-733566

The earth is a ready-made, insulated container with the capacity for months of storage

- Small surface footprint, plus high energy-storage density
 - At 250°C and 10 MPa overpressure, hot water contains > 100 times the energy per unit mass of water in pumped hydro with 1 km of lift
- Operational flexibility
 - Electricity-to-heat storage ratio is controllable over a wide range (useful for nuclear power integration)
 - Control overpressure to prevent flashing and reduce seismic risk by adjusting
 - net storage rate of supplemental fluid and/or
 - fraction of produced brine diverted for beneficial use (e.g., saline cooling)
- Required technology is available from GCS, geothermal, oil and gas, underground gas storage, and power industries

Lawrence Livermore National Laboratory

LLNL-PRES-733566

Earth Battery: store energy with compressed supplemental working fluid and pressurized heated brine

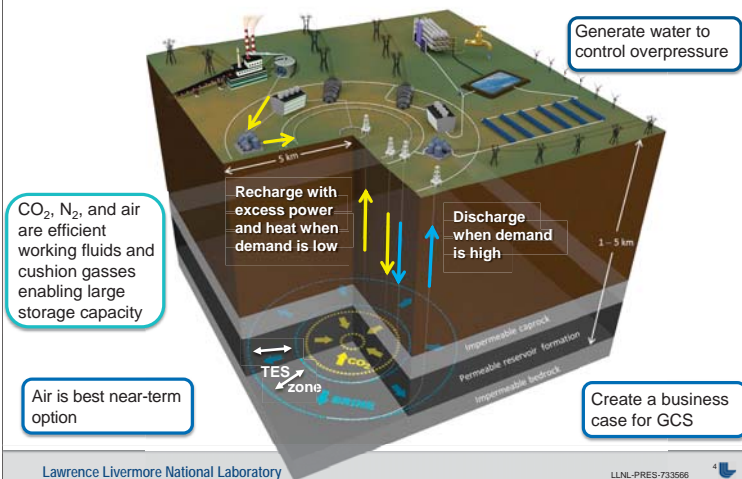

Lawrence Livermore National Laboratory

LLNL-PRES-733566

Containing buoyant supplemental working fluid, heat, and pressure

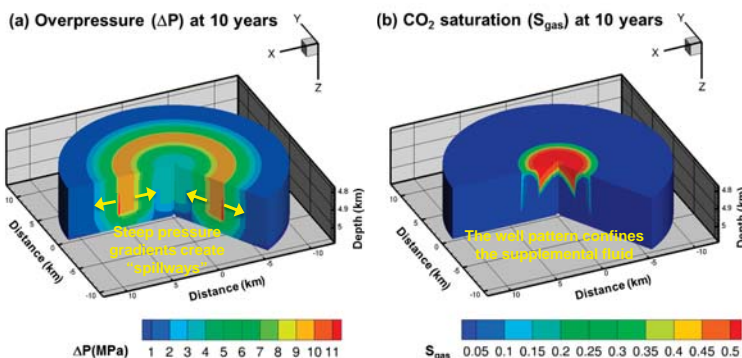

The same configuration applies to air or N₂

Lawrence Livermore National Laboratory

LLNL-PRES-733566

The well arrangement segregates the supplemental-fluid and thermal energy storage (TES) zones

- Caprock and well arrangement confine the buoyant plume of CO₂, N₂, or air
- Because energy density of hot brine is greater than that of the supplemental fluid, the TES zone is more compact

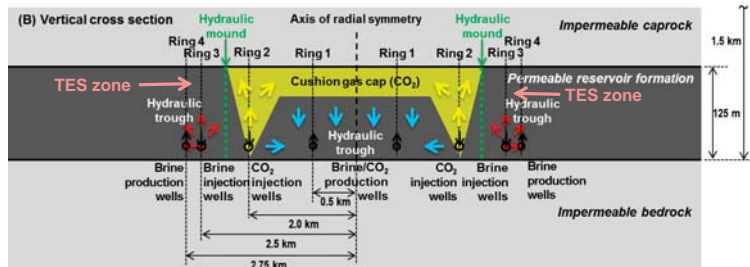

Lawrence Livermore National Laboratory

LLNL-PRES-733566

The Earth Battery can be operated in stand-alone mode to store electricity from the grid or a nuclear power plant

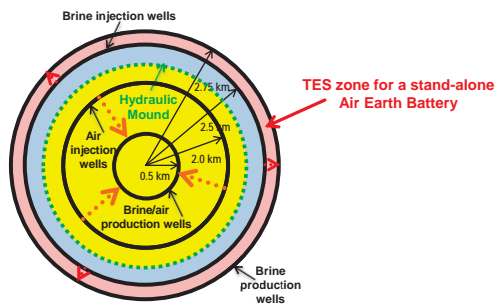

Nesting a stand-alone Earth Battery inside of a nuclear power TES system improves the efficiency of both systems

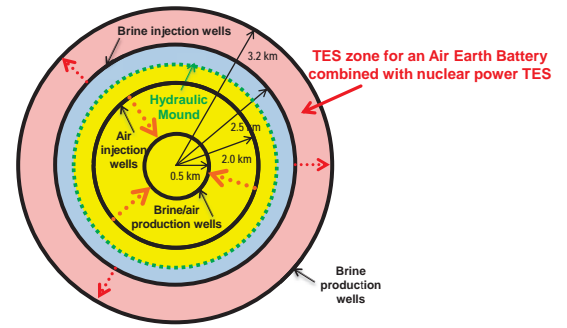

Summary

- Status of the technology
 - Emphasis has been reservoir pressure management and integration with geological CO₂ storage (GCS)
 - Power-system analyses are underway for the Air Earth Battery (adiabatic CAES)
 - Two issued U.S. patents (Summer, 2017) and one submitted U.S. patent
- Next steps
 - Data-constrained reservoir analyses for real geologic settings
 - Detailed power-system analyses and cost estimates
 - Hybrid systems: Air Earth Battery integrated with storing excess heat (e.g., nuclear)
 - Brayton cycle turbines using mixtures of CO₂ and N₂ (longer term option needed for GCS)
 - Pilot study demonstration project

Session III
Path Forward to Commercialization

Electricity Market Characteristics vs. Choice of Thermal Storage Technology

Daniel Curtis
MIT Nuclear Science and Engineering

June 28th, 2017
LWR Heat Storage Workshop - MIT, Cambridge, MA



Outline

- Review the *technology options* and *key parameters*
- *General Features* of electricity markets and available data
- *Examples* of energy storage market potential in *Texas, Iowa, and California*

Review

Technology options and key parameters

Each Heat Storage Option Has Different Characteristics Favoring Different Markets

Technology	Likely Market (Cycle length)	Strengths	Storage Capacity (Estimate of Size)
Accumulator	Hours	Fast Ramp Speeds	100 MWh-1 GWh
Packed Bed	Hours to Days	High Efficiency High Energy Density	1 GWh
Sensible Heat	Hours to Days	Most Relevant Experience (Solar Thermal)	10 GWh
Cryogenic Air	Hours to Days	Lower-Capital-Cost Peak Power System	10 GWh
Crushed Rock	Hours to Weeks	Low-Cost Storage Medium (\$ / MWh)	100 GWh
Geothermal	Hours to Seasonal	Very-low-cost Medium for Seasonal Storage	1 GW-yr

Operating Modes

- **Base-load:** Reactor delivers full steam flow to main turbine as usual.
- **Charging:** Main turbine to minimum power, balance of steam delivered to thermal energy storage system.
- **Discharging:** Reactor delivers full steam flow to main turbine, thermal energy storage delivers full steam flow to turbine.
- Economically optimal results are generally achieved by spending as little time as possible ramping from one mode to another.

Major Physical Parameters of Thermal Energy Storage Systems (TESS)

- Maximum Charging Power (MW_c and/or MW_e)
 - Maximum Charging Ramp Rate (MW / min)
- Maximum Discharge Power (MW_t or MW_e)
 - Maximum Discharge Ramp Rate (MW / min)
- Energy Storage Capacity (MWh)
- Energy Loss Rate
- Round trip efficiency
- Response Time (seconds to hours)
- Low interest in specific examples – *high interest* in the range of feasible system parameters.

Cost Structure for integrated TESS

TESS total cost =

- **Fixed integration cost** +
- **Fixed hardware and construction cost** +
- *Marginal capital cost for charging* * max charging power +
- *Marginal capital cost for discharge* * max discharge power +
- *Marginal capital cost for storage* * storage capacity +
- **Fixed Operating Cost** +
- **Marginal Operating Cost** +
- **Cost of energy stored**

*Project Specific
Characteristic of Technology*

Heat Storage Option Space Much wider than work storage option space

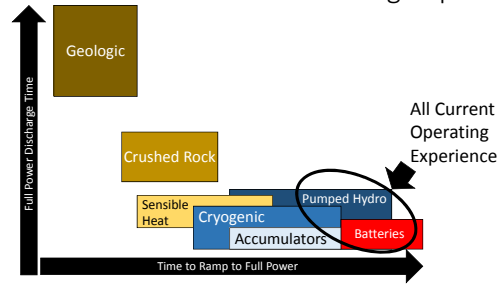

Electricity Markets

Focus on deregulated systems with day-ahead markets and ancillary services

Canonical Day-ahead Market

- Generators submit a set of 24 hourly power offers for the next day by 10am (in ERCOT).
 - Offer X MW at Y \$ / MWh.
- Consumers (industrial and distribution utilities) submit hourly power bids similarly.
- Market operator executes a Unit Commitment and Market Clearing algorithm.
 - Match supply and demand for each hour at minimum cost.

Electric Grid Load and Price Variation – 10 March 2014

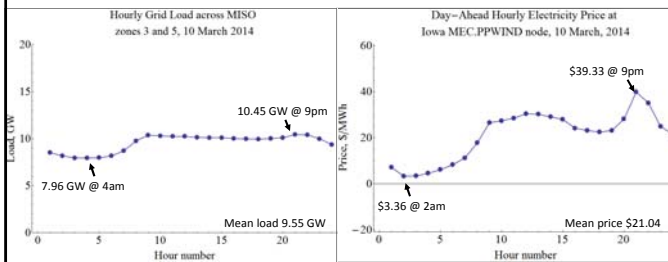

Electric Grid Load and Price Variation – 11 March 2014

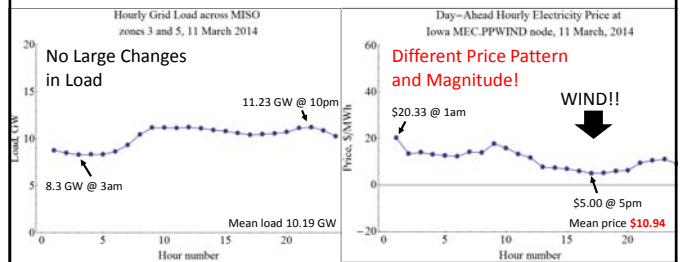

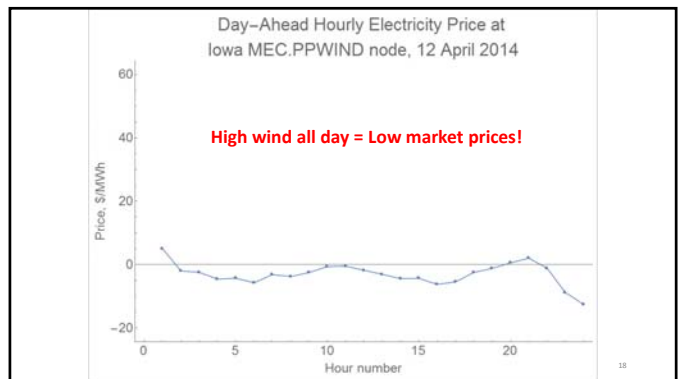
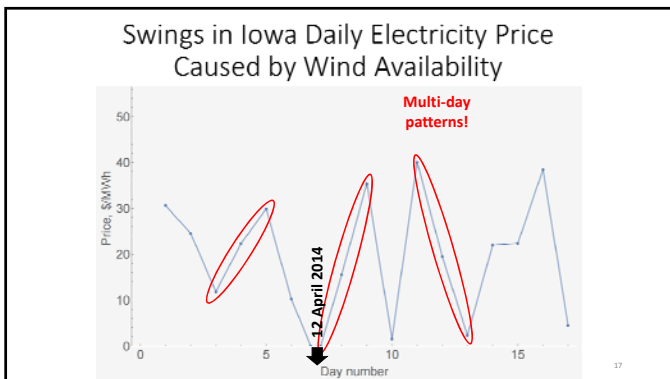
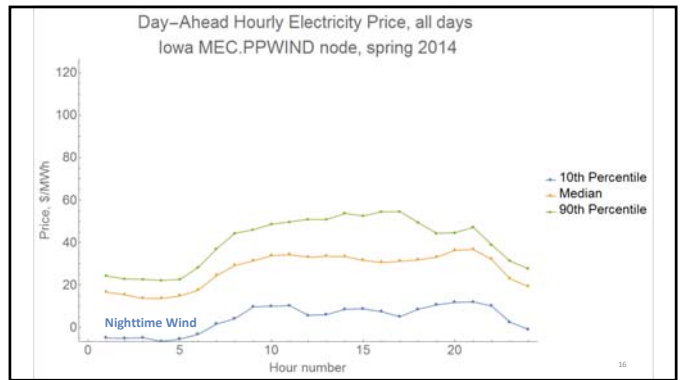
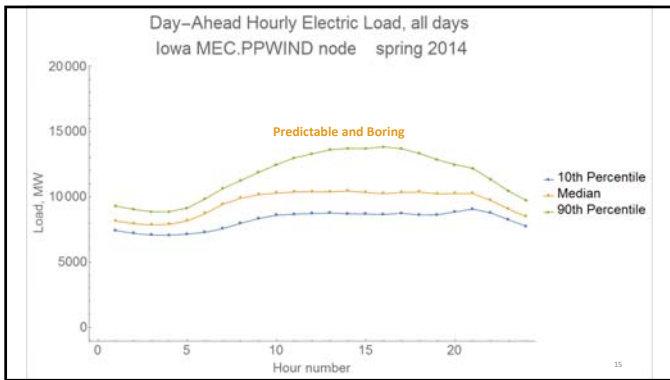
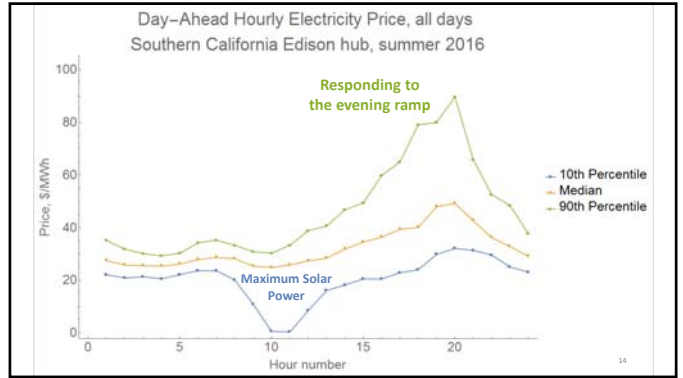
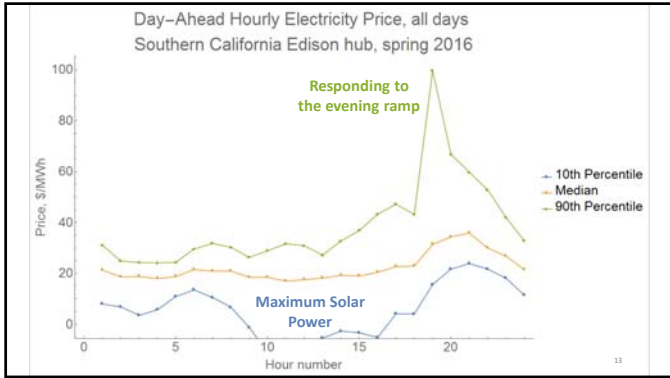

Current Market Examples

Texas: Boringly effective renewable integration and stable market.

Iowa: Overwhelmed by wind.

California: The infamous Duck Curve is real.

19

Daily Cycles - Texas

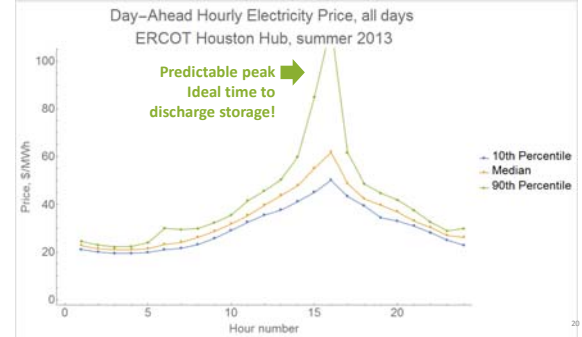

20

Daily Cycles - Iowa

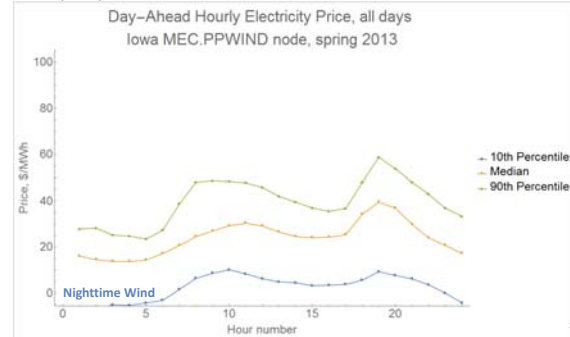

21

Daily Cycles - California

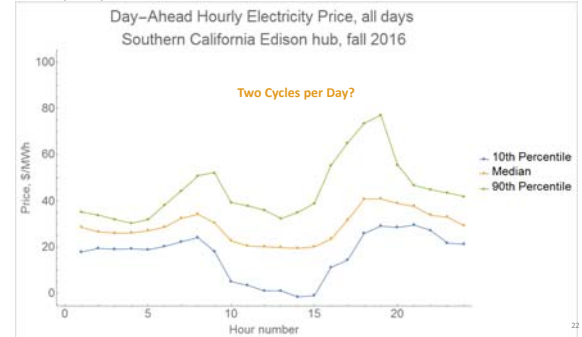

22

Summary of Daily Cycle Potential

Market	Cycle	Special Features?	Predictability?	Potential Value
Texas	Daily	Tall peak for 1-3 hours	Very High	Medium
Iowa	Daily	2 peaks	Low	Medium
California	Daily	2 peaks	Medium	Medium

23

Weekly Cycles - Texas



24

Summary of Weekly Cycle Potential

- **Not Much.**
- No variation that could be used for a weekly charge-discharge strategy seen in any of the 3 markets explored.
- We're watching for market areas with low local demand and high renewable capacity, though...
 - Lower prices could still start reliably appearing on weekends under the right conditions.

Seasonal Cycles - Texas

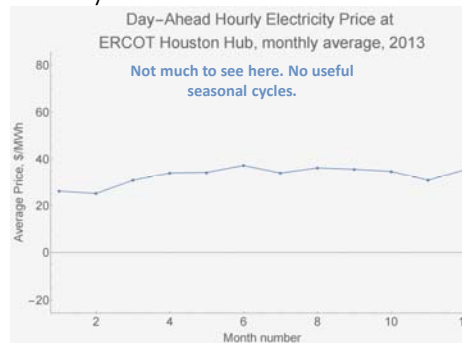

Seasonal Cycles - Iowa

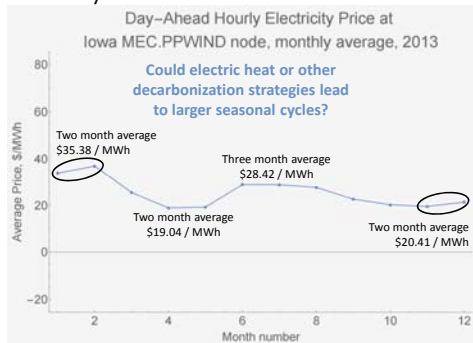

Seasonal Cycles - California

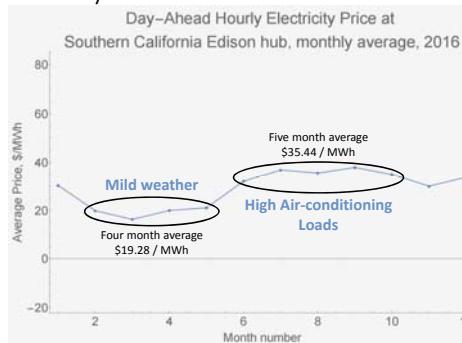

Summary of Seasonal Cycle Potential

Market	Cycle	Special Features?	Predictability?	Potential Value
Texas	Season	None	High	Very Low
Iowa	Season	Winter Peak	High	Medium
California	Season	None	High	Medium

Electricity Market Characteristics vs. Choice of Thermal Storage Technology

Daniel Curtis
MIT Nuclear Science and Engineering

June 28th, 2017
LWR Heat Storage Workshop - MIT, Cambridge, MA



EPRI | ELECTRIC POWER RESEARCH INSTITUTE

Development and Demonstration



Andrew Sowder, Ph.D., CHP
Technical Executive
Advanced Nuclear Technology

MIT Workshop on LWR Heat Storage
Cambridge, MA
June 28, 2017

© 2017 Electric Power Research Institute, Inc. All rights reserved.

Changing Commercial Environment for Nuclear

- Power systems facing unprecedented and accelerating change while maintaining energy and capacity
- Power: only one face of a fragmented energy infrastructure
- New paradigms are sought:
 - flexibility
 - resilience
 - integration
- Uncertainty as only certainty:
 - price of natural gas?
 - price of carbon emissions?
 - new technology (e.g., storage)?

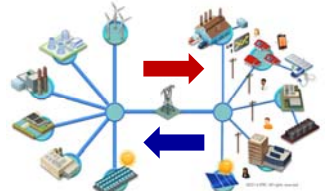

© 2017 Electric Power Research Institute, Inc. All rights reserved.

Markets: One Size Does NOT Fit All...

- Energy policy, market conditions, energy needs vary by country, region
- Business case for technology solutions will vary accordingly



Basis for retail electricity prices by region

© 2017 Electric Power Research Institute, Inc. All rights reserved.

Demonstration

- Purpose: Boost maturity of technology to point of commercial uptake.

One of the greatest challenges that NASA faces in incorporating advanced technologies into future missions is bridging the gap between early development and mission infusion.

NASA presentation to Space Technology Industry Forum, July 13, 2010.

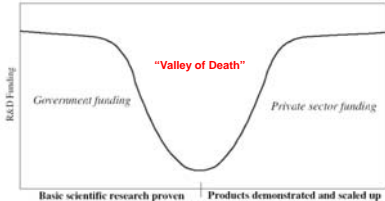

Basic scientific research proven | Products demonstrated and scaled up

<https://thinkprogress.org/government-investment-in-innovation-is-needed-to-overcome-the-valley-of-death-383a64ca35fa>

© 2017 Electric Power Research Institute, Inc. All rights reserved.

Bridging the "Gap"

- Demonstrations present substantial risk and uncertainty not well-suited for purely private sector plays:
 - Lengthy or uncertain timeframes
 - Large capital outlays
 - Limited prospects for near-term ROI
- Historically, public funding or co-funding supported energy technology demonstrations (justified by the promise of a public good return)

Public-Private Roles in Commercialization of Four Global Nuclear Reactor Technologies

	Advanced	Small	Fast	Small	Fast
Technology Attraction	Public	Public	Public	Public	Public
Site Acquisition	Public	Public	Public	Public	Public
Reactor Design	Public	Public	Public	Public	Public
Power Plant Owner	Public	Public	Public	Public	Public
Power Construction R&D	Public	Public	Public	Public	Public
Power Construction R&D	Public	Public	Public	Public	Public
Reactor Plant Design	Public	Public	Public	Public	Public
Power Plant Design	Public	Public	Public	Public	Public
Final Design	Public	Public	Public	Public	Public
Final Fabrication and/or Supply	Public	Public	Public	Public	Public
Power Acquisition (Private sector supported)	Public	Public	Public	Public	Public
Reactor Operation	Public	Public	Public	Public	Public
Power Plant Operation	Public	Public	Public	Public	Public
Reactor Plant Construction	Public	Public	Public	Public	Public
Power Plant Construction	Public	Public	Public	Public	Public

© 2017 Electric Power Research Institute, Inc. All rights reserved.

Key Elements for Demonstration

- Viable, mature technology
- Clear, unambiguous driver (problem, need)
- Funding and resources
- Industry champion
- Interested customer(s)
- Engaged stakeholders



© 2017 Electric Power Research Institute, Inc. All rights reserved.

Current Industry Engagement and Collaboration

- Nuclear generation facing severe market pressures and new operating environment
 - Plants in U.S. now implementing flexible operations
 - Increasing grid variability forcing utilities to expand quest for solutions
 - EPRI has established a Utility Advisory Committee to support INL, NREL, DOE-EE evaluation of nuclear integration with renewables (Nuclear-Renewable Hybrid Energy Systems Program)
- Power systems facing increasing variability and decoupling of peak load from generation
 - Grid-scale energy storage seen as a buffer between electricity supply and demand, increasing the flexibility of the grid and allowing greater accommodation of variable renewable resources
 - EPRI has established the Energy Storage Integration Council (ESIC) to discuss issues and identify gaps related to grid storage

© 2017 Electric Power Research Institute, Inc. All rights reserved.



Energy Storage Integration Council (ESIC)

- Engages utilities, vendors, integrators, and other stakeholders
- Provides a technical forum to
 - Address imminent deployment of storage in distribution contexts
 - To establish best practices and standards
 - To facilitate conversations among key stakeholders

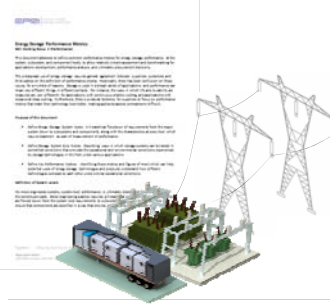

© 2017 Electric Power Research Institute, Inc. All rights reserved.



Utility Hosted Energy Storage System Demonstrations

Multiple Shots on Goal: Chemistries, Applications, Scale

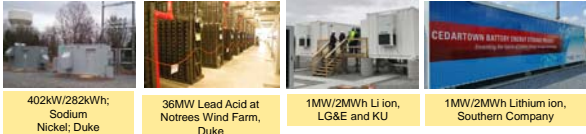

402kW/282kWh: Sodium Nickel; Duke
 36MW Lead Acid at Notrees Wind Farm, Duke
 1MW/2MWh Li ion, LG&E and KU
 1MW/2MWh Lithium ion, Southern Company

- System safety is a critical consideration
- Operational experience essential to understand fire suppression requirements

System integration and operational experience are lacking, even for mature technologies.

© 2017 Electric Power Research Institute, Inc. All rights reserved.



Energy Storage Technologies at Scale

- Cost, performance and reliability must be characterized, understood
- Technology Alone Cannot Solve the Problem
 - Ownership interests and other commercial considerations - many stakeholders share in risks
 - Change in O&M paradigms away from baseload
 - Multiple regulators involved
- Ultimately, energy storage must be integrated into utility planning and operations for full benefit and performance
- What really requires demonstration? The technology or the business case?

© 2017 Electric Power Research Institute, Inc. All rights reserved.



Technology Value and Customer Requirements

- The value and impacts of energy storage are still unclear and not easily monetized
- Customer needs must be understood and addressed vis a vis:
 - Scale
 - Timing
 - Cost
 - Complexity
 - Impacts on safety, operations and maintenance
 - ...

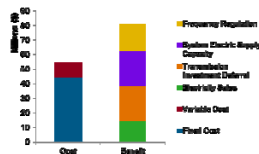

© 2017 Electric Power Research Institute, Inc. All rights reserved.



What Does Successful Demonstration Look Like?

© 2017 Electric Power Research Institute, Inc. All rights reserved.



DOE-FE Clean Coal Technology Demonstration Program

- 33 successfully completed demonstration projects (1986 – 1993)
- >20 technologies tested achieved commercial success
- Tangible results leading to widespread commercial deployment
 - at 75% of U.S. coal plants
 - contributing to reduced emissions of sulfur dioxide, nitrogen oxides and particulates (PM10)
 - valued in 10's of billions USD

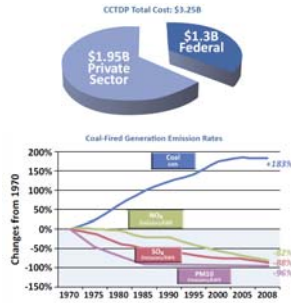

AEC Power Demonstration Reactor Program (PDRP)

- Industry incentives to stimulate U.S. commercial nuclear power (1955 to 1963)
 - Three formal rounds + modified third round
 - 13 projects (8 technologies) incentivized, constructed and operated (many non-LWRs)
 - Other designs explored
- Government support generally included:
 - Funding of preconstruction R&D at either federal labs or at private institutions
 - Waiving fuel use fees during early plant operations
- Industry role generally included:
 - Constructing the balance of plant
 - Operating entire facility
 - Purchasing steam from AEC
- Ownership of nuclear island varied

Private sector cost-sharing at 50% or greater was not unusual

PRDP Round 1: Enrico Fermi Atomic Power Plant

- 200 MWth, 61 MWe sodium-cooled fast reactor
- Designed by industry consortium: Atomic Power Development Associates (APDA)
- Constructed and owned by industry consortium: Power Reactor Development Corporation (PRDC)
- Operated by Detroit Edison: 1963-1966; 1970-1972



Power of an Industry Champion – Walker L. Cisler

- Detroit Edison Company President
- Championed nuclear power in industry and in Congress
- Aggressively pursued development and construction of a commercial-scale NPP
 - Formed and led nonprofit Atomic Power Development Associates comprising 42 industrial entities – architect/engineer
 - Formed, led a second nonprofit, the Power Reactor Development Company - plant owner
- One of first to propose and negotiate an agreement with AEC to construct a demonstration plant under PRDP



Walker L. Cisler, ca. 1984

Mazuzan, G. T. (1982). Atomic Power Safety: The Case of the Power Reactor Development Company Fast Breeder, 1955-1956. *Technology and Culture*, 23(3), 341-371. <http://doi.org/10.2307/3104483>

Closing Thoughts

- Demonstration is the bridge over the divide between R&D and commercialization (valley of death)
- Clear, compelling business case is essential
 - Justifying costs (capital, O&M, etc.)
 - Offering well-understood value
 - Addressing needs at relevant scale and timeframe
 - Fitting within commercial operational envelope
- Ability of private sector to fund large demonstration projects is often overestimated
 - Risks need to be understood and appropriately allocated
 - Large-scale demonstrations often require public-private partnerships